

# **Independent Technical Report on the Yandera Project Pre-feasibility Study**

**Project Areas located on the  
Southwestern Portion of the Province  
of Madang in Papua New Guinea**

**for**

**Era Resources Inc.**

**Effective Date of Mineral Resources and  
Reserves of this Report is 27 November 2017**

## **QUALIFIED PERSONS**

### **Independent Engineering Qualified Person:**

Mr. Tertius le Roux ND, NHD and B Degree: (Mining Engineering),  
Master's Degree (Magister in Mineral Resource Management), (SACMA), (ECSA),  
(FSAIMM), WorleyParsons RSA (Pty) Ltd trading as Advisian

### **Independent Geological Qualified Person:**

J.B. Pennington, M.Sc., C.P.G, SRK Consulting (U.S.)

### **Independent Engineering Qualified Person for Mineral Processing and Metallurgical Testing:**

Marek Dworzanowski, BSc Honours in Mineral Processing (University of Leeds),  
Professional Engineer registered with ECSA, Fellow of the Southern African Institute of  
Mining & Metallurgy (FSAIMM), Adjunct Professor of Metallurgical Engineering  
(University of the Witwatersrand), WorleyParsons RSA (Pty) Ltd trading as Advisian



## Qualified Persons

### Independent Engineering Qualified Person:

Mr. Tertius le Roux ND, NHD and B Degree: Mining Engineering, Master's Degree (Magister in Mineral Resource Management), (SACMA), (ECSA), and Fellow of the Southern African Institute of Mining & Metallurgy (FSAIMM)

WorleyParsons RSA (Pty) Ltd trading as Advisian  
39 Melrose Boulevard, Melrose Arch  
Johannesburg  
2076  
REPUBLIC OF SOUTH AFRICA  
Mobile: +2783 283 4481  
Phone: +2711 218 3885  
E-mail: [Tertius.leroux@advisian.com](mailto:Tertius.leroux@advisian.com)

### Independent Geological Qualified Person:

J.B. Pennington, M.Sc., C.P.G  
SRK Consulting (U.S.), Inc.  
5250 Neil Road, Suite 300  
Reno, Nevada 89502  
Tel: (775) 828-6800  
Fax: (775) 828-6820  
E-mail: [jpennington@srk.com](mailto:jpennington@srk.com)

### Independent Engineering Qualified Person for Mineral and Metallurgical Testing:

Marek Dworzanowski, BSc Honours in Mineral Processing (University of Leeds), Professional Engineer registered with ECSA, Fellow of the Southern African Institute of Mining & Metallurgy (FSAIMM), Adjunct Professor of Metallurgical Engineering (University of the Witwatersrand)

WorleyParsons RSA (Pty) Ltd trading as Advisian  
39 Melrose Boulevard, Melrose Arch  
Johannesburg  
2076  
REPUBLIC OF SOUTH AFRICA  
Mobile: +27 83 296 7432  
Phone: +27 11 483 1691  
E-mail: [marekdworzanowski.advisian@outlook.com](mailto:marekdworzanowski.advisian@outlook.com)



## Operating Companies

### Local Operating Company:

Madang Office  
Guard Dog Complex  
Komoklon Cres, Newtown  
Madang 511  
Papua New Guinea  
Telephone: +675 422 3768  
Facsimile: +675 422 1723

Postal Address:  
PO Box 12, Diwai Post  
Madang  
Papua New Guinea

### Canada Operating Company:

Toronto Office  
c/o Bennett Jones LLP  
3400 First Canadian Place  
100 King Street West  
Toronto, ON M5X 1A4  
CANADA  
Telephone: +1 416 777 4826  
Facsimile: +1 416 863 1716



## AUTHORS OF REPORT

Item	Author/Reviewer	Name	Company	Qualifications
<b>1</b>	<b>EXECUTIVE SUMMARY</b>			
	Author	Robert McGill	Fraser McGill	B.Sc, B.Com, GDE (Mining Eng)
	Reviewer	Carel de Beer	Advisian	PrSciNat BSc (Hons) (Engineering Geology) MEng (Rock Engineering)
	Reviewer	Cindy Howard	Advisian	Pr.Eng. MSAIMM B.Sc. (Chem Eng)
	Reviewer	Cobus Fraser	Fraser McGill	Chartered Accountant – CA(SA) Masters in Business Administration BCom (Hons) Accounting BCom Accounting
	Reviewer	Daniel Moriarty	Coffey	Principal Environmental & Social Consultant, BAHons (Environmental Studies, BSc
	Reviewer	Daniel Sepulveda	SRK	B.Sc SME-RM
	Reviewer	Donovan Munro	Advisian	Pr.Eng. PMP FSAIMM B.Sc. Eng. (Mining) M.Eng(Mining)
	Reviewer	Francois Furstenburg	Advisian	Pr.Eng. BEng (Hons) (Civil)
	Reviewer	Francois Smit	Advisian	BEng (Civil)
	Reviewer	George Shou	BRASS Engineering	P.E. PhD, Chief Engineer
	Reviewer	Hayley Strydom	Advisian	B.Sc. Eng (Chemical Engineering) M.Sc. Eng. (Chemical Engineering)
	Reviewer	Jaco de Kock	Advisian	BTec (Industrial) BCom (Financial Management) BTec (Project Management)
	Reviewer	Jacobus Burger	Advisian	Pr.Eng. MSAIMM BEng (Mining)
	Reviewer	Jay Pennington	SRK	M.Sc. C.P.G.
	Reviewer	Julien Roussel	Advisian	PrSciNat M.Sc. (Geoscience Engineering)
	Reviewer	Kyle Kemp	PCC	NDip (Building)
	Reviewer	Marek Dworzanowski	Advisian	Pr.Eng. FSAIMM B.Sc. (Hons) (Mineral Processing)
	Reviewer	Mike Lelliot	Advisian	Chartered Geologist (Geological Society of London), Member International Association of Hydrogeologists, BSc Geology, MSc Hydrogeology and Groundwater Quality
	Reviewer	Robert McGill	Fraser McGill	B.Sc, B.Com, GDE (Mining Eng)





Item	Author/Reviewer	Name	Company	Qualifications
	Reviewer	Tertius le Roux	Advisian	FSAIMM MSc. Eng. (Mineral Resource Management)
	Reviewer	Tjaart Prinsloo	Advisian	Pr.Cert.Eng. PMP GCC Dip (Electrical Engineering)
	Reviewer	Donovan Munro	Advisian	Pr.Eng. PMP FSAIMM B.Sc. Eng. (Mining) M.Eng(Mining)
<b>2</b>	<b>INTRODUCTION</b>			
	Author	Martin Prior	Advisian	MSc (Mining)
	Reviewer	Donovan Munro	Advisian	Pr.Eng. PMP FSAIMM B.Sc. Eng. (Mining) M.Eng(Mining)
	Reviewer	Jaco de Kock	Advisian	BTec (Industrial) BCom (Financial Management) BTec (Project Management)
<b>3</b>	<b>RELIANCE ON OTHER EXPERTS</b>			
	Author	Jaco de Kock	Advisian	BTec (Industrial) BCom (Financial Management) BTec (Project Management)
	Reviewer	Tertius le Roux	Advisian	FSAIMM MSc. Eng. (Mineral Resource Management)
	Reviewer	Marek Dworzanowski	Advisian	Pr.Eng. FSAIMM B.Sc. (Hons) (Mineral Processing)
	Reviewer	Jay Pennington	SRK	M.Sc. C.P.G.
	Reviewer	Daniel Sepulveda	SRK	B.Sc SME-RM
<b>4</b>	<b>PROPERTY DESCRIPTION AND LOCATION</b>			
	Author	Robert McGill	Fraser McGill	B.Com. (Financial)
	Reviewer	Jaco de Kock	Advisian	BTec (Industrial) BCom (Financial Management) BTec (Project Management)
	Reviewer	Donovan Munro	Advisian	Pr.Eng. PMP FSAIMM B.Sc. Eng. (Mining) M.Eng(Mining)
<b>5</b>	<b>ACCESSIBILITY, CLIMATE, LOCAL RESOURCES, INFRASTRUCTURE AND PHYSIOGRAPHY</b>			
	Author	Martin Prior	Advisian	MSc (Mining)
	Reviewer	Jaco de Kock	Advisian	BTec (Industrial) BCom (Financial Management) BTec (Project Management)
	Reviewer	Donovan Munro	Advisian	Pr.Eng. PMP FSAIMM B.Sc. Eng. (Mining) M.Eng(Mining)



Item	Author/Reviewer	Name	Company	Qualifications
<b>6</b>	<b>HISTORY</b>			
	Author	Martin Prior	Advisian	MSc (Mining)
	Reviewer	Jaco de Kock	Advisian	BTec (Industrial) BCom (Financial Management) BTec (Project Management)
	Reviewer	Donovan Munro	Advisian	Pr.Eng. PMP FSAIMM B.Sc. Eng. (Mining) M.Eng(Mining)
<b>7</b>	<b>GEOLOGICAL SETTING AND MINERALIZATION</b>			
	Author	Jay Pennington	SRK	M.Sc. C.P.G.
	Reviewer	Tertius le Roux	Advisian	FSAIMM MSc. Eng. (Mineral Resource Management)
<b>8</b>	<b>DEPOSIT TYPES</b>			
	Author	Jay Pennington	SRK	M.Sc. C.P.G.
	Reviewer	Tertius le Roux	Advisian	FSAIMM MSc. Eng. (Mineral Resource Management)
<b>9</b>	<b>EXPLORATION</b>			
	Author	Jay Pennington	SRK	M.Sc. C.P.G.
	Reviewer	Tertius le Roux	Advisian	FSAIMM MSc. Eng. (Mineral Resource Management)
<b>10</b>	<b>DRILLING</b>			
	Author	Jay Pennington	SRK	M.Sc. C.P.G.
	Reviewer	Tertius le Roux	Advisian	FSAIMM MSc. Eng. (Mineral Resource Management)
<b>11</b>	<b>SAMPLE PREPARATION, ANALYSES AND SECURITY</b>			
	Author	Jay Pennington	SRK	M.Sc. C.P.G.
	Reviewer	Tertius le Roux	Advisian	FSAIMM MSc. Eng. (Mineral Resource Management)
<b>12</b>	<b>DATA VERIFICATION</b>			
	Author	Jay Pennington	SRK	M.Sc. C.P.G.
	Reviewer	Tertius le Roux	Advisian	FSAIMM MSc. Eng. (Mineral Resource Management)
<b>13</b>	<b>MINERAL PROCESSING AND METALLURGICAL TESTING</b>			
	Author	Hayley Strydom	Advisian	B.Sc. Eng (Chemical Engineering) M.Sc. Eng. (Chemical Engineering)
	Reviewer	Marek Dworzanowski	Advisian	Pr.Eng. FSAIMM B.Sc. (Hons) (Mineral Processing)
<b>14</b>	<b>MINERAL RESOURCE ESTIMATES</b>			
	Author	Jay Pennington	SRK	M.Sc. C.P.G.



Item	Author/Reviewer	Name	Company	Qualifications
	Reviewer	Tertius le Roux	Advisian	FSAIMM MSc. Eng. (Mineral Resource Management)
<b>15</b>	<b>MINERAL RESERVE ESTIMATES</b>			
	Author	Tertius le Roux	Advisian	FSAIMM MSc. Eng. (Mineral Resource Management)
	Reviewer	Donovan Munro	Advisian	Pr.Eng. PMP FSAIMM B.Sc. Eng. (Mining) M.Eng(Mining)
<b>16</b>	<b>MINING METHODS</b>			
	Author	Tertius le Roux	Advisian	FSAIMM MSc. Eng. (Mineral Resource Management)
	Author	Carel de Beer	Advisian	PrSciNat BSc (Hons) (Engineering Geology) MEng (Rock Engineering)
	Reviewer	Donovan Munro	Advisian	Pr.Eng. PMP FSAIMM B.Sc. Eng. (Mining) M.Eng(Mining)
	Reviewer	Julien Roussel	Advisian	PrSciNat M.Sc. (Geoscience Engineering)
<b>17</b>	<b>RECOVERY METHODS</b>			
	Author	Cindy Howard	Advisian	Pr.Eng. MSAIMM B.Sc. (Chem Eng)
	Reviewer	Marek Dworzanowski	Advisian	Pr.Eng. FSAIMM B.Sc. (Hons) (Mineral Processing)
<b>18</b>	<b>PROJECT INFRASTRUCTURE</b>			
	Author	Francois Furstenburg	Advisian	Pr.Eng. BEng (Hons) (Civil)
	Author	Tjaart Prinsloo	Advisian	Pr.Cert.Eng. PMP GCC Dip (Electrical Engineering)
	Author	George Shou	BRASS Engineering	P.E. PhD, Chief Engineer
	Author	Ricardo Camardella de Souza	Advisian	Diploma in Civil Engineering
	Reviewer	Jaco de Kock	Advisian	BTec (Industrial) BCom (Financial Management) BTec (Project Management)
	Reviewer	Francois Smit	Advisian	BEng (Civil)
	Reviewer	Donovan Munro	Advisian	Pr.Eng. PMP FSAIMM B.Sc. Eng. (Mining) M.Eng(Mining)
<b>19</b>	<b>MARKET STUDIES AND CONTRACTS</b>			
	Author	Cobus Fraser	Fraser McGill	Chartered Accountant – CA(SA) Masters in Business Administration



Item	Author/Reviewer	Name	Company	Qualifications
				BCom (Hons) Accounting BCom Accounting
	Reviewer	Robert McGill	Fraser McGill	B.Sc, B.Com, GDE (Mining Eng)
	Reviewer	Donovan Munro	Advisian	Pr.Eng. PMP FSAIMM B.Sc. Eng. (Mining) M.Eng(Mining)
<b>20</b>	<b>ENVIRONMENTAL STUDIES, PERMITTING AND SOCIAL OR COMMUNITY IMPACT</b>			
	Author	Daniel Moriarty	Coffey	Principal Environmental & Social Consultant, BAHons (Environmental Studies, BSc
	Reviewer	Jaco de Kock	Advisian	BTec (Industrial) BCom (Financial Management) BTec (Project Management)
	Reviewer	Donovan Munro	Advisian	Pr.Eng. PMP FSAIMM B.Sc. Eng. (Mining) M.Eng(Mining)
<b>21</b>	<b>CAPITAL AND OPERATING COSTS</b>			
	Author	Kyle Kemp	PCC	NDip (Building)
	Author	Jacobus Burger	Advisian	Pr.Eng. MSAIMM BEng (Mining)
	Reviewer	Cobus Fraser	Fraser McGill	Chartered Accountant – CA(SA) Masters in Business Administration BCom (Hons) Accounting BCom Accounting
	Reviewer	Donovan Munro	Advisian	Pr.Eng. PMP FSAIMM B.Sc. Eng. (Mining) M.Eng(Mining)
<b>22</b>	<b>ECONOMIC ANALYSIS</b>			
	Author	Cobus Fraser	Fraser McGill	Chartered Accountant – CA(SA) Masters in Business Administration BCom (Hons) Accounting BCom Accounting
	Reviewer	Jacobus Burger	Advisian	Pr.Eng. MSAIMM BEng (Mining)
	Reviewer	Donovan Munro	Advisian	Pr.Eng. PMP FSAIMM B.Sc. Eng. (Mining) M.Eng(Mining)
<b>23</b>	<b>ADJACENT PROPERTIES</b>			
	Author	Daniel Moriarty	Coffey	Principal Environmental & Social Consultant, BAHons (Environmental Studies, BSc
	Reviewer	Jaco de Kock	Advisian	BTec (Industrial) BCom (Financial Management) BTec (Project Management)



Item	Author/Reviewer	Name	Company	Qualifications
	Reviewer	Donovan Munro	Advisian	Pr.Eng. PMP FSAIMM B.Sc. Eng. (Mining) M.Eng(Mining)
<b>24</b>	<b>OTHER RELEVANT DATA AND INFORMATION</b>			
	Author	Daniel Moriarty	Coffey	Principal Environmental & Social Consultant, BAHons (Environmental Studies, BSc
	Reviewer	Jaco de Kock	Advisian	BTec (Industrial) BCom (Financial Management) BTec (Project Management)
	Reviewer	Donovan Munro	Advisian	Pr.Eng. PMP FSAIMM B.Sc. Eng. (Mining) M.Eng(Mining)
<b>25</b>	<b>INTERPRETATION AND CONCLUSIONS</b>			
	Author	Robert McGill	Fraser McGill	B.Sc, B.Com, GDE (Mining Eng)
	Reviewer	Jaco de Kock	Advisian	BTec (Industrial) BCom (Financial Management) BTec (Project Management)
	Reviewer	Donovan Munro	Advisian	Pr.Eng. PMP FSAIMM B.Sc. Eng. (Mining) M.Eng(Mining)
<b>26</b>	<b>RECOMMENDATIONS</b>			
	Author	Robert McGill	Fraser McGill	B.Sc, B.Com, GDE (Mining Eng)
	Reviewer	Jaco de Kock	Advisian	BTec (Industrial) BCom (Financial Management) BTec (Project Management)
	Reviewer	Donovan Munro	Advisian	Pr.Eng. PMP FSAIMM B.Sc. Eng. (Mining) M.Eng(Mining)



# Table of Contents

<b>1</b>	<b>EXECUTIVE SUMMARY .....</b>	<b>1</b>
1.1	OVERVIEW .....	1
1.2	KEY FINDINGS .....	1
1.3	CONCLUSIONS .....	3
1.4	STUDY RESPONSIBILITIES .....	4
1.5	PROPERTY DESCRIPTION AND OWNERSHIP.....	4
1.6	GEOLOGY AND MINERALIZATION.....	6
1.7	STATUS OF EXPLORATION, DEVELOPMENT AND OPERATIONS .....	6
1.8	MINERAL PROCESSING AND METALLURGICAL TESTING.....	7
1.9	MINERAL RESOURCE ESTIMATE .....	8
1.10	MINERAL RESERVE ESTIMATE.....	9
1.11	MINING METHODS.....	9
1.12	GEOTECHNICAL INVESTIGATION .....	10
1.13	RECOVERY METHODS.....	10
1.14	PROJECT INFRASTRUCTURE.....	12
1.15	ENVIRONMENT STUDIES AND PERMITTING .....	14
1.16	OPERATING AND CAPITAL COSTS.....	17
1.17	FINANCIAL ANALYSIS .....	24
<b>2</b>	<b>INTRODUCTION.....</b>	<b>26</b>
2.1	ISSUER.....	26
2.2	TERMS OF REFERENCE AND PURPOSE OF THIS REPORT .....	26
2.3	SOURCES OF INFORMATION.....	26
2.4	INVOLVEMENT OF THE QUALIFIED PERSON AND PERSONAL INSPECTIONS .....	27
2.5	FREQUENTLY USED ACRONYMS, ABBREVIATIONS, DEFINITIONS AND UNITS OF MEASURE.....	28
2.6	SPECIFIC AREAS OF RESPONSIBILITY .....	31
2.7	EFFECTIVE DATES .....	32
<b>3</b>	<b>RELIANCE ON OTHER EXPERTS.....</b>	<b>33</b>
<b>4</b>	<b>PROPERTY DESCRIPTION AND LOCATION .....</b>	<b>34</b>
4.1	PROPERTY LOCATION.....	34
4.2	MINERAL TENURE.....	34
4.3	ROYALTIES, AGREEMENT AND ENCUMBRANCES.....	35
4.4	OTHER FACTORS AND RISKS.....	36
<b>5</b>	<b>ACCESSIBILITY, CLIMATE, LOCAL RESOURCES, INFRASTRUCTURE AND PHYSIOGRAPHY .....</b>	<b>37</b>
5.1	TOPOGRAPHY, ELEVATION AND VEGETATION.....	37



5.2	ACCESSIBILITY AND TRANSPORTATION TO THE PROPERTY .....	38
5.3	CLIMATE AND LENGTH OF OPERATING SEASON.....	39
5.4	SUFFICIENCY OF SURFACE RIGHTS.....	41
5.5	INFRASTRUCTURE AVAILABILITY AND SOURCES .....	42
<b>6</b>	<b>HISTORY.....</b>	<b>44</b>
6.1	PRIOR OWNERSHIP AND OWNERSHIP CHANGES .....	44
6.2	EXPLORATION AND DEVELOPMENT RESULTS OF PREVIOUS OWNERS .....	44
6.3	HISTORICAL MINERAL RESOURCES AND RESERVE ESTIMATES .....	44
6.4	PRODUCTION FROM THE PROPERTY.....	46
<b>7</b>	<b>GEOLOGICAL SETTING AND MINERALIZATION .....</b>	<b>47</b>
7.1	REGIONAL GEOLOGY.....	47
7.2	LOCAL SETTING.....	50
7.3	PROPERTY GEOLOGY .....	50
7.4	SIGNIFICANT MINERALIZED ZONES.....	53
<b>8</b>	<b>DEPOSIT TYPES .....</b>	<b>59</b>
8.1	MINERAL DEPOSIT.....	59
8.2	GEOLOGICAL MODEL .....	59
<b>9</b>	<b>EXPLORATION.....</b>	<b>60</b>
9.1	RELEVANT EXPLORATION WORK .....	60
9.2	SAMPLING METHODS AND SAMPLE QUALITY.....	60
9.3	SIGNIFICANT RESULTS AND INTERPRETATION .....	62
<b>10</b>	<b>DRILLING .....</b>	<b>63</b>
10.1	TYPE AND EXTENT .....	63
10.2	PROCEDURES.....	69
10.3	INTERPRETATION AND RELEVANT RESULTS .....	70
<b>11</b>	<b>SAMPLE SECURITY, PREPARATION AND ANALYSIS.....</b>	<b>71</b>
11.1	SECURITY MEASURES .....	71
11.2	SAMPLE PREPARATION FOR ANALYSIS.....	71
11.3	SAMPLE ANALYSIS.....	71
11.4	QUALITY ASSURANCE/QUALITY CONTROL PROCEDURES.....	72
11.5	OPINION ON ADEQUACY.....	89
<b>12</b>	<b>DATA VERIFICATION.....</b>	<b>90</b>
12.1	PROCEDURE.....	90
12.2	LIMITATIONS .....	91
12.3	OPINION AND DATA ADEQUACY.....	92
<b>13</b>	<b>MINERAL PROCESSING AND METALLURGICAL TESTING .....</b>	<b>93</b>



13.1	THE NATURE AND EXTENT OF THE TESTING AND ANALYTICAL PROCEDURES .....	93
13.2	BASIS FOR ANY ASSUMPTIONS.....	126
13.3	PROCESSING FACTORS HAVING EFFECTS ON POTENTIAL ECONOMIC EXTRACTION .....	140
13.4	FORWARD WORK PLAN.....	141
<b>14</b>	<b>MINERAL RESOURCE ESTIMATES .....</b>	<b>144</b>
14.1	INTRODUCTION.....	144
14.2	PROJECT COORDINATES.....	144
14.3	DRILLHOLE DATABASE .....	144
14.4	TOPOGRAPHY.....	145
14.5	GEOLOGICAL MODEL .....	145
14.6	MINERAL DOMAINS FOR INTERPOLATION.....	146
14.7	OXIDE MODEL .....	148
14.8	BLOCK MODEL.....	151
14.9	ASSAY CAPPING.....	153
14.10	COMPOSITING.....	153
14.11	VARIOGRAM ANALYSIS AND MODELLING .....	155
14.12	GRADE ESTIMATION .....	159
14.13	DENSITY MODELLING.....	163
14.14	MODEL VALIDATION .....	163
14.15	RESOURCE CLASSIFICATION.....	167
14.16	MINERAL RESOURCE STATEMENT.....	168
14.17	MINERAL RESOURCE SENSITIVITY.....	171
14.18	RELEVANT FACTORS .....	172
14.19	RESOURCE POTENTIAL .....	172
<b>15</b>	<b>MINERAL RESERVES ESTIMATES.....</b>	<b>173</b>
15.1	INTRODUCTION.....	173
15.2	GEOLOGICAL RESOURCE ESTIMATE VALIDATION.....	174
15.3	INITIAL MINING MODIFYING FACTORS.....	175
15.4	DESIGN PIT SHELL DETERMINATION .....	183
15.5	CONCENTRATE GRADE PREDICTION.....	200
15.6	MOISTURE CONTENT .....	201
15.7	GEOTECHNICAL CONSIDERATIONS.....	201
15.8	WHITTLE ANALYSIS .....	204
15.9	INITIAL PIT DESIGN.....	213
15.10	PIT DESIGN OPTIMIZATION PROCESS .....	218
15.11	FINAL PIT DESIGN.....	218





15.12	PRODUCTION SCHEDULING.....	227
15.13	EQUIPMENT SELECTION .....	228
15.14	OPEX AND CAPEX.....	228
15.15	FINANCIAL MODEL.....	230
15.16	MINERAL RESERVE ESTIMATION .....	230
<b>16</b>	<b>MINING METHODS .....</b>	<b>233</b>
16.1	INTRODUCTION.....	233
16.2	OPEN PIT SLOPE DESIGN.....	233
16.3	MINING STRATEGY .....	244
16.4	MINE OPERATIONS .....	271
<b>17</b>	<b>RECOVERY METHODS .....</b>	<b>279</b>
17.1	PROPOSED PROCESSING METHODS.....	279
17.2	PLANT DESIGN.....	284
17.3	EQUIPMENT CHARACTERISTICS AND SPECIFICATIONS.....	299
17.4	PROJECTED REQUIREMENTS FOR ENERGY, WATER AND PROCESS MATERIALS.....	310
17.5	RISK.....	314
17.6	REFERENCE DOCUMENTS AND DRAWINGS .....	315
<b>18</b>	<b>PROJECT INFRASTRUCTURE .....</b>	<b>319</b>
18.1	INTRODUCTION.....	319
18.2	PROJECT INFRASTRUCTURE.....	319
18.3	POWER SUPPLY AND DISTRIBUTION.....	327
18.4	ROADS .....	329
18.5	RAIL FACILITIES .....	332
18.6	AIR TRANSPORTATION.....	332
18.7	PORT FACILITIES.....	332
18.8	BARGING FACILITIES .....	338
18.9	PROJECT FACILITIES AND UTILITIES.....	340
18.10	MINE PIT INFRASTRUCTURE AND LOGISTICS.....	343
18.11	DUMPS AND STOCKPILES.....	345
18.12	TAILINGS DISPOSAL.....	346
18.13	ORE SLURRY TRANSFER SYSTEM.....	347
18.14	WATER FACILITIES.....	348
<b>19</b>	<b>MARKET STUDIES AND CONTRACTS .....</b>	<b>351</b>
19.1	INTRODUCTION.....	351
19.2	INDUSTRY OUTLOOK – SUPPLY.....	351
19.3	INDUSTRY OUTLOOK – DEMAND .....	352



19.4	SUPPLY AND DEMAND BALANCE.....	353
19.5	COPPER INDUSTRY THREATS AND OPPORTUNITIES.....	354
19.6	COMMODITY PRICE FORECAST .....	354
19.7	REALIZATION CHARGES .....	355
19.8	MARKET STRATEGY AND PRODUCT CHARACTERISTICS.....	357
19.9	REQUIRED CONTRACTS FOR PROPERTY DEVELOPMENT .....	357
<b>20</b>	<b>ENVIRONMENTAL STUDIES, PERMITTING AND SOCIAL OR COMMUNITY IMPACT .....</b>	<b>358</b>
20.1	KNOWN ENVIRONMENTAL ASPECTS.....	358
20.2	REQUIREMENTS AND PLANS.....	377
20.3	POTENTIAL SOCIAL OR COMMUNITY REQUIREMENTS AND PLANS .....	379
20.4	REQUIRED PERMIT AND STATUS .....	382
20.5	MINE CLOSURE REQUIREMENTS AND COSTS.....	386
<b>21</b>	<b>CAPITAL AND OPERATING COSTS.....</b>	<b>391</b>
21.1	CAPITAL COST ESTIMATE.....	391
21.2	ESTIMATE CRITERIA .....	391
21.3	ESTIMATING METHODOLOGIES.....	395
21.4	ASSUMPTIONS .....	399
21.5	ESTIMATING METHODOLOGIES – YANDERA COPPER PROJECT.....	400
21.6	INPUTS TO CAPEX ESTIMATING.....	405
21.7	CASH FLOW, ESCALATION AND FOREX FLUCTUATIONS.....	405
21.8	OPERATING COST ESTIMATE .....	407
<b>22</b>	<b>ECONOMIC ANALYSIS .....</b>	<b>435</b>
22.1	KEY PROJECT VARIABLES.....	435
22.2	ASSUMPTIONS AND INVESTMENT EVALUATION PRACTICES.....	437
22.3	VALUATION RESULTS .....	443
22.4	SENSITIVITIES ANALYSIS.....	444
22.5	SCENARIO ANALYSIS .....	445
<b>23</b>	<b>ADJACENT PROPERTIES .....</b>	<b>447</b>
<b>24</b>	<b>OTHER RELEVANT DATA AND INFORMATION .....</b>	<b>448</b>
<b>25</b>	<b>INTERPRETATION AND CONCLUSIONS.....</b>	<b>449</b>
25.1	GENERAL.....	449
25.2	MINERAL RESOURCE .....	449
25.3	GEOTECHNICAL.....	450
25.4	HYDROLOGY/WATER MANAGEMENT .....	450
25.5	MINING METHODS AND MINE DESIGN.....	450
25.6	MINERAL RESERVE.....	450



25.7	METALLURGY AND PROCESSING.....	451
25.8	INFRASTRUCTURE.....	451
25.9	ENVIRONMENTAL AND SOCIO-ECONOMIC ASPECTS AND PERMITTING .....	452
25.10	MARKETING AND CONTRACTS.....	453
25.11	FINANCIAL EVALUATION .....	453
25.12	RISK.....	454
<b>26</b>	<b>RECOMMENDATIONS.....</b>	<b>459</b>
26.1	RECOMMENDED WORK PROGRAMMES.....	459
26.2	GEOTECHNICAL.....	460
26.3	HYDROLOGICAL CONSIDERATION .....	461
26.4	MINING METHODS AND MINE DESIGN.....	461
26.5	MINERAL RESERVE.....	462
26.6	METALLURGICAL PROCESSING .....	462
26.7	INFRASTRUCTURE.....	463
26.8	FINANCIAL/BUSINESS CASE.....	483
26.9	OPERATING COST .....	483
26.10	CAPITAL COST .....	483
<b>27</b>	<b>REFERENCES .....</b>	<b>484</b>
<b>28</b>	<b>GLOSSARY .....</b>	<b>488</b>
<b>29</b>	<b>DATE AND SIGNATURE PAGE.....</b>	<b>489</b>
29.1	CERTIFICATE OF QUALIFIED PERSON – T. LE ROUX.....	489
29.2	CERTIFICATE OF QUALIFIED PERSON – M. DWORZANOWSKI .....	491
29.3	CERTIFICATE OF QUALIFIED PERSON – J.B. PENNINGTON.....	493
29.4	CERTIFICATE OF QUALIFIED VALUATOR – C. FRASER .....	495
29.5	CERTIFICATE OF QUALIFIED PERSON – D.H. SEPULVEDA.....	497

## List of Tables

Table 1-1: Mineral Resource Statement for the Yandera Copper, Molybdenum, Gold Deposit, Madang Province, Papua New Guinea [0.15 CuEq (%) Cut-off] SRK Consulting, December 15, 2016	8
Table 1-2: Total Probable Mineral Reserves Estimate	9
Table 1-3: Mining Operating Cost Breakdown	18
Table 1-4: Processing Cost Summary	19
Table 1-5: Operating Cost Breakdown	20
Table 1-6: Capital Cost Estimate for Major Plant Areas	23
Table 1-7: Valuation Results	25
Table 2-1: Qualified Persons Site Visits	27



Table 2-2: Abbreviations and Definitions	28
Table 2-3: Areas of Responsibility	31
Table 4-1: Era Mineral Titles and Status	34
Table 6-1: Yandera Mineral Resource Statement by Golder 2011 at 0.2% Copper Equivalent Cut-off Grade	45
Table 6-2: Yandera Mineral Resource Estimate by Ravensgate 2012 at 0.2% Copper Cut-off Grade	45
Table 6-3: Yandera Mineral Resource Statement by SRK 2015 at 0.15% Copper Equivalent Cut-off Grade	46
Table 10-1: Summary of Yandera Drilling by Deposit Area and Property Owner	63
Table 10-2: 2012-2014 Era Drilling Programmes	65
Table 10-3: Era 2016 Drilling Programmes	66
Table 11-1: Method Detection Limits for Key Elements	72
Table 11-2: Mean Values of CRM in 2016 Drilling Programme	73
Table 11-3: Certified Values and Method Detection Limits for Blank Samples	82
Table 12-1: Summary of 2016 Drillhole Data Verification	91
Table 12-2: Summary of Verification, Pre-2016 Drillholes	91
Table 13-1: Summary of Comminution Results (AMMTEC 2008)	93
Table 13-2: Comparison of Rougher Flotation Performance of Omora, Gremi and Imbruminda Utilizing Proposed Rougher Flotation Conditions	103
Table 13-3:- Summary of Locked Cycle Test Work – Configuration 1	107
Table 13-4: - Summary of Locked Cycle Test Work – Configuration 2	109
Table 13-5:- Summary of Locked Cycle Test Work – Configuration 3	109
Table 13-6: Low-grade Locked Cycle Test work Results	110
Table 13-7: Gremi Mixed Ore Samples Sighter Tests on Low S:Cu Ratio, High Visual Oxide with Effect of NaHS Addition	114
Table 13-8: Rougher Flotation Results –Gremi Oxide	117
Table 13-9: Comparison of Gremi Oxide Result to Modal Analysis	117
Table 13-10: Summary of Levin Regrind Index Results	118
Table 13-11: Tailings Thickening Design Parameters	121
Table 13-12 : Concentrate Thickening Design Parameters	123
Table 13-13: Cu Concentrate Quality (Based on Locked Cycle Products of Two Stage Cleaning Tests)	124
Table 13-14: Upper Concentration Limits for Importing Copper Concentrates	124
Table 13-15: Typical Cu Smelter Penalty Element Schedule	125
Table 13-16: Mo Concentrate Quality	125
Table 13-17: Concentrate Properties	126
Table 13-18: Cu Recovery Prediction Algorithms, excluding the 2% derating for Scale-up	127
Table 13-19: Cu Recovery Prediction Algorithms, including the 2% derating for Scale-up	128
Table 13-20: Au Recovery Prediction Algorithms, excluding the 2% De-rating for Scale-up	129



Table 13-21: Au Recovery Prediction Algorithms, including the 2% De-rating for Scale-up	129
Table 13-22: Mo Recovery Prediction Algorithms, excluding the 2% De-rating for Scale-up	130
Table 13-23: Mo Recovery Prediction Algorithms, including the 2% De-rating for Scale-up	131
Table 13-24: Yandera – Oxide Flotation Test Work Results	133
Table 13-25: Benchmark – Oxide Flotation Projects (SRK, 2017)	137
Table 13-26: Distribution of Comminution Samples within Target Zones	138
Table 14-1: Metallurgical Materials and Approximate Copper Recoveries by Flotation	149
Table 14-2: Yandera 3D Block Model Extents	151
Table 14-3: Yandera 3D Block Model Items	152
Table 14-4: Copper Assay Capping Values by Lithological Unit	153
Table 14-5: Molybdenum Assay Capping Values by Lithological Unit	153
Table 14-6: Gold Assay Capping Values by Lithological Unit	153
Table 14-7: Yandera Copper Composite Statistics by CUDOM, SDOM, and LITH	154
Table 14-8: Yandera Molybdenum Composite Statistics by MODOM, SDOM, and LITH	154
Table 14-9: Yandera Gold Composite Statistics by AUDOM, SDOM, and LITH	155
Table 14-10: Average Yandera PLQ Grades (rounded to reflect accuracy)	155
Table 14-11: Copper Variogram Parameters by Cu Interpolation Domain	158
Table 14-12: Gold Variogram Parameters by Au Interpolation Domain	158
Table 14-13: Ordinary Kriging Interpolation Parameters for the Yandera Copper Estimation	161
Table 14-14: Density Variogram Parameters by Model Area	163
Table 14-15: Full Model Summary Statistics for SG by Level of Oxidation	163
Table 14-16: Mineral Resource Statement for the Yandera Copper, Molybdenum, Gold Deposit, Madang Province, Papua New Guinea [0.15 CuEq (%) Cut-off] SRK Consulting, December 15, 2016	169
Table 14-17: Yandera Total MI&I Resource Sensitivity within the 2016 SRK Resource Pit	171
Table 15-1: Input Parameters for the Resource Estimation Validation	174
Table 15-2: Resource Estimation Validation	175
Table 15-3: Ore Losses Already Included in Block Model	177
Table 15-4: Mining Dilution to be added to the Block Model	181
Table 15-5: Resource Estimation Validation	183
Table 15-6: Long-term CPI Forecasts	184
Table 15-7: Wood Mackenzie Copper Price Forecast – March 2017	185
Table 15-8: Molybdenum Price Forecast	186
Table 15-9: Copper Payable Scale	187
Table 15-10: Gold Payable Scale	187
Table 15-11: Diesel Supply Cost at Yandera	189
Table 15-12: Operating Cost per Tonne	189



Table 15-13: Operating Cost per tonne	190
Table 15-14: 5-year Aggregate Wood Mackenzie Analysis	191
Table 15-15: Yandera 2012 Mine Opex Rates	192
Table 15-16: Long-term Crude Oil Price Forecast (USD/barrel)	193
Table 15-17: Local (PNG) Spend Analysis	193
Table 15-18: PGK:USD Exchange Rate	194
Table 15-19: Papua New Guinea Minimum Wages	194
Table 15-20: Revised Mining Opex for Whittle	195
Table 15-21: Cu Recovery Prediction Algorithms, excluding the 2% De-rating for Scale –up	196
Table 15-22: Cu Recovery Prediction Algorithms, including the 2% De-rating for Scale-up	197
Table 15-23: Au Recovery Prediction Algorithms, excluding the 2% De-rating for Scale-up	198
Table 15-24: Au Recovery Prediction Algorithms, including the 2% De-rating for Scale-up	199
Table 15-25: Mo Recovery Prediction Algorithms, including the 2% De-rating for Scale-up	200
Table 15-26: Final Concentrate Grades and their Basis	201
Table 15-27: Whittle Analysis Progression based on M&I – Block Model tonnes	206
Table 15-28: Yandera Whittle Inputs: Final Analysis	210
Table 15-29: Pit Shell 37 Summary	212
Table 15-30: Mine Design Criteria	214
Table 15-31: Initial Pit Design Tonnages	217
Table 15-32: Breakdown of Operating Costs	229
Table 15-33: Financial Analysis	230
Table 15-34: Total Probable Mineral Reserves Estimate	230
Table 15-35: Hill Top Access and Haul Road In-Pit Probable Reserves per Geological Domain	231
Table 15-36: Production Probable Reserves Estimate per Geological Domain	232
Table 15-37: Production Reserve per Geological Domain	232
Table 16-1: Recommended Slope Design Angles for First Whittle Run	236
Table 16-2: Blasting Parameters defined for Ore and Waste	238
Table 16-3: Proposed Pre-split Design	239
Table 16-4: Orientations of Major Structures	240
Table 16-5: Results of the Kinematic Analysis for Planar Wedge and Toppling Failure Mechanisms for Mech, Stack, Inter-ramp and Overall Slope Configurations	241
Table 16-6: Slope Configuration based on Required Catch Bench Capacity	242
Table 16-7: Road Construction Equipment	246
Table 16-8: Haul and Hilltop Access Bulk Earthworks Quantities	247
Table 16-9: Design Parameters	248
Table 16-10: Pit Ranking	252



Table 16-11: Initial Target-Based Production Schedule (Year 1 = 2020)	262
Table 16-12: Mine Planning Based Production Schedule (Year 1 = 2020)	263
Table 16-13: Production Schedule of all Geological Domains (Year 1 = 2020)	265
Table 16-14: North (Geo-Domain 1) Production Schedule (Year 1 = 2020)	266
Table 16-15: Dimbi (Geo-Domain 2) Production Schedule (Year 1 = 2020)	267
Table 16-16: Imbruminda (Geo-Domain 3) Production Schedule (Year 1 = 2020)	268
Table 16-17: Gremi (Geo-Domain 4) Production Schedule (Year 1 = 2020)	269
Table 16-18: Omora (Geo-Domain 5) Production Schedule (Year 1 = 2020)	270
Table 16-19: Working Calendar	271
Table 16-20: Productive and Non-Productive Time	271
Table 16-21: Available Time	273
Table 16-22: Maximum Theoretical Production Rates of Drilling Equipment	274
Table 16-23: Capacity of Load and Haul Equipment	275
Table 16-24: Application of Ancillary Equipment	276
Table 16-25: Ancillary Equipment (Year 1 = 2020)	277
Table 17-1: Production Schedules	287
Table 17-2: Ore Head Grades	287
Table 17-3: Concentrate Production	287
Table 17-4: Ore Physical Characteristics	288
Table 17-5: Key Sizing Parameters for Unit Operations	288
Table 17-6: Specifications for Mills	301
Table 17-7: Rougher Flotation Circuit Details	306
Table 17-8: Cleaner Flotation Circuit Details	306
Table 17-9: Molybdenite Flotation Circuit Details	307
Table 17-10: Blower System Details	309
Table 17-11: Summary of Installed and Absorbed Power – Process Plant	310
Table 17-12: Yandera Plant and Facilities High Level Water Balance – Steady State Operation	311
Table 17-13: Flotation Plant Reagent and Media Consumption Schedule – Sulphide Ore	313
Table 17-14: Flotation Plant Reagent and Media Consumption Schedule – Oxide Ore	313
Table 17-15: Milling Plant Reagent and Media Consumption Schedule	314
Table 17-16: Engineering Design Documents for the Yandera Process Plant	315
Table 17-17: Engineering Drawings for the Yandera Process Plant	317
Table 19-1: Wood Mackenzie Copper Price Forecast (USD /lb) – June 2017	354
Table 19-2: Copper Payable Scale	356
Table 19-3: Gold Payable Scale	356
Table 20-1: Relevant Legislation and Regulations	385



Table 20-2: Domain Definitions	387
Table 21-1: Summary of Estimated Cost broken down per WBS	391
Table 21-2: Criteria Ranges	392
Table 21-3: Results Achieved for Accuracy Assessment	392
Table 21-4: Mining Capex Estimate Breakdown	396
Table 21-5: Estimating Methodology Split for Mining Section	397
Table 21-6: Estimating Split for Yandera Precinct	397
Table 21-7: Estimating Methodology Split for Yandera Precinct Section	397
Table 21-8: Estimating Split for Milling Plant to Coastal Facilities	398
Table 21-9: Estimating Methodology Split for Milling Plant to Coastal Facilities Section	398
Table 21-10: Estimating Split for Coastal Facilities	398
Table 21-11: Estimating Methodology Split for Coastal Facilities Section	399
Table 21-12: Forex Exchange Rates used to prepare Capital Direct Cost Estimate	406
Table 21-13: Ore Slurry Capital Cost Summary	406
Table 21-14: DSTP Capital Cost Summary	406
Table 21-15: Paterson Grading – Labour Rates per Month	409
Table 21-16: Unavailable Allowances	410
Table 21-17: Additional Compensation	410
Table 21-18: Ownership Cost Assumptions	412
Table 21-19: Drilling Cost Calculation	413
Table 21-20: Blasting Cost Calculation	414
Table 21-21: Excavator Cost Calculation	414
Table 21-22: Truck Hauling Cost Calculation	416
Table 21-23: Auxiliary Services Cost Calculation	416
Table 21-24: Dewatering Cost Calculation	417
Table 21-25: Fixed Costs Breakdown over LoM	419
Table 21-26: Mining Operating Cost Breakdown	419
Table 21-27: Level of Confidence	420
Table 21-28: Level of Accuracy	421
Table 21-29: Milling Plant Reagents and Consumables Cost	422
Table 21-30: Sulphide Flotation Plant Reagents and Consumables Cost	423
Table 21-31: Oxide Flotation Plant Reagents and Consumables Cost	423
Table 21-32: Mo Circuit Plant Reagents and Consumables Cost	424
Table 21-33: Plant Labour Cost Summary	425
Table 21-34: Plant Maintenance Cost per Annum	425
Table 21-35: Plant Power Cost Tonne Milled	426





Table 21-36: Miscellaneous Cost per Annum	426
Table 21-37: Processing Cost Summary	426
Table 21-38: Level of Accuracy	428
Table 21-39: General and Administration Labour Breakdown	429
Table 21-40: General and Administration Cost per Annum	430
Table 21-41: Ore Slurry Pipeline Operating Cost	431
Table 21-42: DSTP Operating Cost	431
Table 21-43: Other Maintenance Cost per Annum	431
Table 21-44: Operating Cost Breakdown	432
Table 22-1: Acceptable Methods of Mineral Project Valuation	437
Table 22-2: Valuation Assumptions	438
Table 22-3: Capital Estimate used for Valuation Purposes	442
Table 22-4: Valuation Results	443
Table 22-5: Upside Scenario	445
Table 22-6: Downside Scenario	446
Table 25-1: Total Probable Mineral Reserves Estimate	451
Table 25-2: Risk Breakdown Structure	454
Table 25-3: Overview of the Risk Categories of the Yandera Project	455
Table 25-4: Highest Identified Risks	456

## List of Figures

Figure 1-1: Mining Profile	2
Figure 1-2: Plant Feed Profile	3
Figure 1-3: Project Location Map	5
Figure 1-4: Exploration Tenure Map	5
Figure 1-5: Processing Schematic	11
Figure 1-6: Yandera Mine Site Layout	13
Figure 1-7: Coastal Facilities Conceptual Layout	14
Figure 1-8: Mining Cost Contribution by Element	18
Figure 1-9: Processing Cost Breakdown	19
Figure 1-10: Total Cost Contribution by Element	20
Figure 1-11: Cost Breakdown per Sub-activity	21
Figure 1-12: Opex DNA Summary (USD/milled tonne)	22
Figure 1-13: Total Capital Cost Contribution by Element	23
Figure 1-14: Project DNA Structure (USD)	24
Figure 4-1: Project Location Map	34



Figure 4-2: Land Tenure Map	35
Figure 5-1: Site Access Map	39
Figure 7-1: Geologic Terranes of New Guinea	48
Figure 7-2: Regional Geology Map	49
Figure 7-3: Local Geology Map	51
Figure 7-4: Property Geology Map	52
Figure 7-5: Property Alteration Map	52
Figure 7-6: Main Mineralized Zones	54
Figure 7-7: Property Geology and Cross Section Index Map	55
Figure 7-8: Geologic Cross Section GME_73_Gremi	55
Figure 7-9: Geologic Cross Section GME_64_Gremi	56
Figure 7-10: Geologic Cross Section GME_46_Gremi	56
Figure 7-11: Geologic Cross Section GME_37_Gremi	57
Figure 7-12: Geologic Cross Section GME_26_Omora	57
Figure 7-13: Geologic Cross Section GME_17_Omora	58
Figure 9-1: Regional Exploration Work by Company	61
Figure 9-2: Era 2016 Surface Exploration	61
Figure 9-3: Resource Potential along the North West / South East Strike	62
Figure 10-1: Location of Drillhole Collars by Company	65
Figure 10-2: Recent Era Drilling from 2012 to 2014	66
Figure 10-3: Era 2016 Drilling Summary	67
Figure 10-4: Era 2017 Drilling Summary	68
Figure 11-1: Copper Results for OREAS 501b	73
Figure 11-2: Copper Results for OREAS 502b	74
Figure 11-3: Copper Results for OREAS 503b	74
Figure 11-4: Copper Results for OREAS 504b	75
Figure 11-5: Molybdenum Results for OREAS 501b	76
Figure 11-6: Molybdenum Results for OREAS 502b	76
Figure 11-7: Molybdenum Results for OREAS 503b	77
Figure 11-8: Molybdenum Results for OREAS 504b	77
Figure 11-9: Gold Results for OREAS 501b	78
Figure 11-10: Gold Results for OREAS 502b	78
Figure 11-11: Gold Results for OREAS 503b	79
Figure 11-12: Gold Results for OREAS 504b	79
Figure 11-13: Sulphur Results for OREAS 501b	80
Figure 11-14: Sulphur Results for OREAS 502b	81



Figure 11-15: Sulphur Results for OREAS 503b	81
Figure 11-16: Sulphur Results for OREAS 504b	82
Figure 11-17: Copper Results for Blank Samples	83
Figure 11-18: Molybdenum Results for Blank Samples	83
Figure 11-19: Gold Results for Blank Samples	84
Figure 11-20: Sulphur Results for Blank Samples	84
Figure 11-21: Check Assay Relative Percent Difference vs. Average Value, Copper	85
Figure 11-22: Check Assay Relative Percent Difference vs. Average Value, Molybdenum	86
Figure 11-23: Check Assay Relative Percent Difference vs. Average Value, Gold	86
Figure 11-24: Coarse Reject Duplicates Relative Percent Difference, Moly	87
Figure 11-25: Coarse Reject Duplicates Relative Percent Difference, Moly	87
Figure 11-26: Coarse Reject Duplicates Relative Percent Difference, Gold	88
Figure 11-27: Coarse Reject Duplicates Relative Percent Difference, Sulphur	88
Figure 13-1: Variability in Ore Competency (Axb) for Samples derived from Gremi	94
Figure 13-2: Variability in Ore Competency (Axb) for Samples derived from Omora	94
Figure 13-3: Frequency Plot – Ore Competency	95
Figure 13-4: Variability in Bond Ball Work Index for Samples derived from Gremi	95
Figure 13-5: Variability in Bond Ball Work Index Samples derived from Omora	96
Figure 13-6: Frequency Plot – Bond Ball Work Index	96
Figure 13-7: The Indicative Comminution Specific Energy Requirements of the Yandera Project in Relation to Similar Low-grade Cu Porphyry Projects	97
Figure 13-8: Effect of Cu Head Grade on Cu Recovery (Gremi and Omora)	99
Figure 13-9: Effect of Grind on Cu Recovery (Gremi and Omora Samples)	100
Figure 13-10: Effect of Grind on Mo Recovery	100
Figure 13-11: Effect of Grind on Cu Cleaner Concentrate Grade	104
Figure 13-12: Effect of Grind on Cu Cleaner Recovery	105
Figure 13-13: Effect of Grind on Mo Cleaner Recovery	105
Figure 13-14: Process Flowsheet Configurations for Locked Cycle Test Work	108
Figure 13-15: Locked Cycle Test Work Flowsheet – Low-grade Samples	110
Figure 13-16: Effect of Grind on Cu Recovery – Dimbi Samples	112
Figure 13-17: Effect of Grind on Cu Recovery – Dimbi Samples	112
Figure 13-18: Cu Department in the Rougher Tailings	116
Figure 13-19: Comparison of Yandera Levin Test Results to Similar Ore Types	119
Figure 13-20: Settling Rates for Yandera Tailings Material Using Various Flocculants	120
Figure 13-21: Settling Rates for Yandera Cu Concentrate Using Various Flocculants	122
Figure 13-22: Filtration Rates for Yandera Cu Concentrate under Various Conditions	123



Figure 13-23: Grade Recovery Correlation for Cu Recovery for Sulphide Ore Type, based on Metallurgical Test Work (excludes de-ration for scale-up)	128
Figure 13-24: Grade Recovery Correlation for Au Recovery for Sulphide Ore Type, based on Metallurgical Test Work (excludes de-ration for scale-up)	130
Figure 13-25: Copper Recovery vs. Percentage Copper associated to Sulphide Minerals	133
Figure 13-26: Rougher Copper Recovery vs. Concentrate Mass Pull	134
Figure 13-27: Gold Recovery vs. Copper Recovery (Accumulated)	134
Figure 13-28: Spatial Distribution of Borehole Cores used for Comminution Test Work Programme	139
Figure 14-1: Resource Drilling in Model Area, Highlighting 2016 Drill Collars	146
Figure 14-2: Yandera Structural Domains and 0.15% Copper Grade Shell	148
Figure 14-3: Modelled Oxidation Boundaries with Drillhole Contact points, East-West Section at 9,365,330m North, Dimbi Deposit	150
Figure 14-4: Oxidation Coding in 2016Block Model, East-West Section at 9,365,330m North	151
Figure 14-5: Copper Downhole Correlogram – Gremi-Imbrum: BX Lithology	156
Figure 14-6: Copper Correlogram - Major Axis – Gremi-Imbrum: BX Lithology	156
Figure 14-7: Copper Correlogram – Semi Major Axis – Gremi-Imbrum: BX Lithology	157
Figure 14-8: Copper Correlogram – Minor Axis - Gremi-Imbrum: BX Lithology	157
Figure 14-9: Figure 14 9: Copper Search Ellipses Relative to Lithology Groupings	159
Figure 14-10: Visual Grade Validation – Plan View	164
Figure 14-11: Visual Grade Validation – Longitudinal Section View	165
Figure 14-12: Model Validation - Modelled Cu OK vs. Cu NN vs. Composite Cu CAP	165
Figure 14-13: East/West Copper Swath Plot – 75m	166
Figure 14-14 : North/South Copper Swath Plot – 75m	167
Figure 14-15: Elevation Copper Swath Plot – 20m – All Domains	167
Figure 14-16: Yandera Estimated Blocks Coloured by Classification Code	168
Figure 14-17: Yandera 2016 Resource Pit in Plan with 1,500ppm Copper Interpolation Domains	170
Figure 14-18: Optimized Pit Price Sensitivity Reported at a CuEq Cut-off of 0.15%	172
Figure 15-1: Process for Mineral Reserves Estimation	173
Figure 15-2: Ore Losses Depicted as Voids between Blocks and Grade Shell Perimeter	176
Figure 15-3: Mining Dilution depicted by Ore Blocks extending into Waste	179
Figure 15-4: Wood Mackenzie Cost Analysis	191
Figure 15-5: Cu Grade Recovery Correlation-Sulphide Ore (excludes de-ration)	198
Figure 15-6: Au Grade Recovery Correlation-Sulphide Ore (excludes de-ration)	199
Figure 15-7: Recommended Maximum Overall Slope Angles -- Initial Whittle Run	202
Figure 15-8: Yandera Geotech Slope Angles	203
Figure 15-9: Whittle Progression Waterfall Chart – M&I	205
Figure 15-10: Yandera Whittle Sensitivity – Pit Size	207



Figure 15-11: Yandera Whittle Sensitivity – Potential Reserve tonnage	207
Figure 15-12: Chronological Sequence of Whittle Analysis	208
Figure 15-13: WRD and Oxide Ore Stockpile Designs	209
Figure 15-14: Pit Exit Reference Elevations	209
Figure 15-15: Yandera PFS Whittle Family of Nested Pits Graph	211
Figure 15-16: Yandera PFS Whittle Family of Nested Pits Graph	213
Figure 15-17: Whittle Pit Shell 37	213
Figure 15-18: Initial Pit Design	215
Figure 15-19: Initial Hill Top Access and Haul Road Design	215
Figure 15-20: Hill Top Access and Haul Road Development	219
Figure 15-21: Final Pit Design within Topography	219
Figure 15-22: Pit Design Locality	221
Figure 15-23: Location of Pits	222
Figure 15-24: Hill top Access and Haul Roads	222
Figure 15-25: Layout of the Pits	223
Figure 15-26: Total Pit N-S Section (A-A)	223
Figure 15-27: Total Pit W-E Section (B-B)	223
Figure 15-28: Gamagu Pit Dimensions	224
Figure 15-29: Dimbi Pit Dimensions	224
Figure 15-30: Imbruminda Pit Dimensions	225
Figure 15-31: Gremi Pit Dimensions	225
Figure 15-32: Omora Pit Dimensions	226
Figure 15-33: South 1 Pit Design – Location for Crusher Pad	226
Figure 15-34: South 2 Pit Design – Operational Stockpile Area	227
Figure 15-35: Plant Feed over the Life of Mine	228
Figure 15-36: Total Capital Cost Estimate of the Yandera Project (USDmil)	229
Figure 16-1: Conceptual Slope Design Angles (After Hayes & Terbrugge)	236
Figure 16-2: Design Catch Bench Geometry	238
Figure 16-3: Slope Stability Analysis for the Waste Rock Dump	240
Figure 16-4: Design Sectors 1-8 with Proposed Slope Angles	241
Figure 16-5: Slope Configuration for the Intack Rock Slopes	243
Figure 16-6: Slope Configuration for the Oxidized Zone	243
Figure 16-7: Development of the initial cut	245
Figure 16-8: Plan view of the proposed stage two-road construction	245
Figure 16-9: Rock Fall Risk for Different High Wall Heights	250
Figure 16-10: Slope Failure Impact Area for different High Wall Heights	250



Figure 16-11: Commencement of Mining after Establishment of Hill Top Access and Haul Road Network (Start of Year 3 – 2022)	253
Figure 16-12: End of the First Year of Production (Year 3 – 2022)	254
Figure 16-13: End of the Second Year of Production (Year 4 – 2023)	254
Figure 16-14: End of the Third Year of Production (Year 5 – 2024)	254
Figure 16-15: End of the Fourth Year of Production (Year 6 – 2025)	255
Figure 16-16: End of the Fifth Year of Production (Year 7 – 2026)	255
Figure 16-17: End of the Sixth Year of Production (Year 8 – 2027)	255
Figure 16-18: End of the Seventh Year of Production (Year 9 – 2028)	255
Figure 16-19: End of the Eighth Year of Production (Year 10 – 2029)	256
Figure 16-20: End of the Ninth Year of Production (Year 11 – 2030)	256
Figure 16-21: End of the Tenth Year of Production (Year 12 – 2031)	256
Figure 16-22: End of the Eleventh Year of Production (Year 13 – 2032)	257
Figure 16-23: End of the Twelfth Year of Production (Year 14 – 2033) – Backfilling into Gremi Commences	257
Figure 16-24: End of the Thirteenth Year of Production (Year 15 – 2034) – Backfilling into Gremi	257
Figure 16-25: End of the Fourteenth Year of Production (Year 16 – 2035) - Backfilling into Gremi	258
Figure 16-26: End of the Fifteenth Year of Production (Year 17 – 2036) - Backfilling into Gremi	258
Figure 16-27: End of the Sixteenth Year of Production (Year 18 – 2037) - Backfilling into Gremi	258
Figure 16-28: End of the Sixteenth Year of Production (Year 18 – 2037) after Backfilling into Gremi	259
Figure 16-29: Period Progress Plot for the Pit	260
Figure 16-30: Period Progress Plot – Waste Dumping	260
Figure 16-31: Initial Target-Based Production Schedule (Year 1 = 2020)	262
Figure 16-32: Mine Planning Based Production Schedule (Year 1 = 2020)	263
Figure 16-33: Geological Domains used for Production Scheduling	264
Figure 16-34: Production Schedule of all Geological Domains (Year 1 = 2020)	265
Figure 16-35: North (Geo-Domain 1) Production Schedule (Year 1 = 2020)	266
Figure 16-36: Dimbi (Geo-Domain 2) Production Schedule (Year 1 = 2020)	267
Figure 16-37: Imbruminda (Geo-Domain 3) Production Schedule (Year 1 = 2020)	268
Figure 16-38: Gremi (Geo-Domain 4) Production Schedule (Year 1 = 2020)	269
Figure 16-39: Omora (Geo-Domain 5) Production Schedule (Year 1 = 2020)	270
Figure 16-40: Mine Roster Cycle	273
Figure 16-41: Production Requirements of the Mine (Year 1 = 2020)	274
Figure 16-42: Number of Drill Rigs over the Life of Mine (Year 1 = 2020)	275
Figure 16-43: Number of Load and Haul Equipment over the Life of Mine (Year 1 = 2020)	276
Figure 17-1: Process Flow Schematic	280



Figure 17-2: Geologic Terranes of New Guinea	281
Figure 17-3: Major Mineral Projects in PNG	282
Figure 17-4: Conceptual View of Mills and Coarse Ore Stockpile	285
Figure 17-5: Conceptual View of Coastal Facilities at Cape Rigny	285
Figure 17-6: Plant Feed Profile	296
Figure 17-7: SABC Mill Specific Energy Predictions (kWh/t)	298
Figure 17-8: Conceptual View of Copper Concentrate Ship Loading Operation	308
Figure 18-1: Site Location	319
Figure 18-2: Yandera Project Infrastructure	320
Figure 18-3: Yandera Mining Precinct	322
Figure 18-4: Mining Pit Areas and Waste Rock Dump	324
Figure 18-5: Conceptual Layout of Coastal Facilities at Cape Rigny	326
Figure 18-6: Potential Overhead Line Route	327
Figure 18-7: Location of Proposed Cape Rigny Coastal Facilities	331
Figure 18-8: Photograph of the Preferred Site for the Port Infrastructure located along northwestern shore of Cape Rigny	333
Figure 18-9: Proposed Site for the Port Installation and Wave Roses derived from the Wave Transformation Study	334
Figure 18-10: Cross section of the Suspended Piled Deck Proposed for the Quay	335
Figure 18-11: 3D Rendering of Port Facility	337
Figure 18-12: Photo of the Proposed Landing Barge	339
Figure 18-13: Rendered Image of the Proposed Landing Passenger Boat	339
Figure 18-14: Proposed Barging Route between the Port of Madang and Cape Rigny	340
Figure 18-15: Proposed Route of the Slurry Pipeline from the Yandera to Cape Rigny	347
Figure 18-16: Pipeline System Schematic	348
Figure 19-1: Supply-demand Balance (Source: Wood Mackenzie)	353
Figure 20-1: Ramu River at the Foot of the Bismarck Range	359
Figure 20-2: Typically Steep Landscape around Mine Area	360
Figure 20-3: Tai-Yor River Valley with Yandera Exploration Camp and Village in Foreground	360
Figure 20-4: Yandera Copper Project Location	362
Figure 20-5: Nearshore Marine Environment at Cape Rigny	365
Figure 20-6: Yandera Village	373
Figure 20-7: Vegetation around the Mine Area	374
Figure 21-1: Major WBS Areas and Cost Allocations (millions)	396
Figure 21-2: Estimating Process Split	399
Figure 21-3: Cost Structure Example	408



Figure 21-4: Actual Contractor Rates Comparison	413
Figure 21-5: Hauling Distances and Hauling Cost	415
Figure 21-6: Production Labour Complement	417
Figure 21-7: Mining Cost Contribution by Element	420
Figure 21-8: Processing Cost Breakdown	427
Figure 21-9: Total Cost Contribution by Element	432
Figure 21-10: Cost Breakdown per Sub-activity	433
Figure 21-11: Opex DNA Summary	434
Figure 22-1: Key Project Variables	436
Figure 22-2: Key Valuation Dates	439
Figure 22-3: Production Schedule and Plant Feed	439
Figure 22-4: Prioritised Ore Feed	440
Figure 22-5: Gross Revenue including By-products	441
Figure 22-6: Gross Revenue per Commodity Type	441
Figure 22-7: Annual Cash Flow	444
Figure 22-8: Sensitivity Analysis	445
Figure 26-1: Resource Potential along the North West / South East Strike	460

## Appendix List

Appendix A: SRK Yandera Oxide Recovery Estimate





# 1 Executive Summary

The following items are the main components forming the purpose of the Pre-Feasibility Study (PFS):

- To determine the optimal techno-economic solution that considers all opportunities and risks, and is aligned with the owner’s strategy.
- To justify the expenditure on a Definitive Feasibility Study (DFS) of the selected project option.
- To evaluate certain project options as a converging view, and to demonstrate that the selected option is superior.
- To determine targets for further value enhancement and risk reduction.

## 1.1 Overview

The Yandera Project is 100% owned by Era Resources Inc. (Era). Yandera is a substantial copper deposit in Papua New Guinea (PNG) that has the potential to be a large-scale producer for decades. WorleyParsons RSA (Pty) Ltd trading as Advisian (Advisian) was appointed by Era to compile an NI 43-101 compliant PFS on the Yandera Project taking cognisance of the following:

- How can the project be moved further up the value curve in an efficient and cost-effective manner?
- What scenarios and options can be considered to ensure maximum value?
- What are the key technical and non-technical risks and opportunities of this Project?

The purpose of this Report is to present the findings of the PFS in accordance with Canadian National Instrument 43-101 Standards of Disclosure for Mineral Projects (NI 43-101), NI 43-101 Form F1, and Canadian Institute of Mining (CIM), “Best Practices and Reporting Guidelines.” Hence, the objective of this Report and PFS is to evaluate the technical feasibility and economic viability of the development of an open pit mine, processing facilities and associated infrastructures.

## 1.2 Key Findings

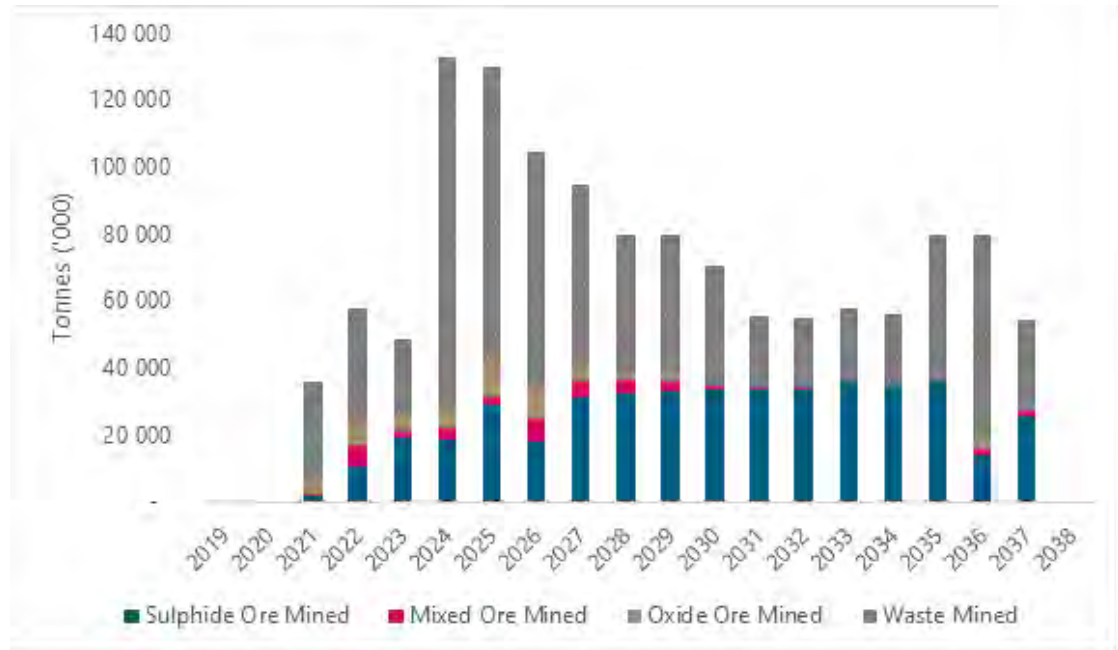
The Yandera Project has been shown to be technically and economically viable with strong financial returns as can be seen in the table below:

Cost Item	Unit	Cost
NPV – Real	USD million	1,038
IRR – Real	%	23.5
Project Capital (excluding national infrastructure) – Real	USD million	930
Payback Period – Real	years	5 years, 8 months
Life of Mine	years	20



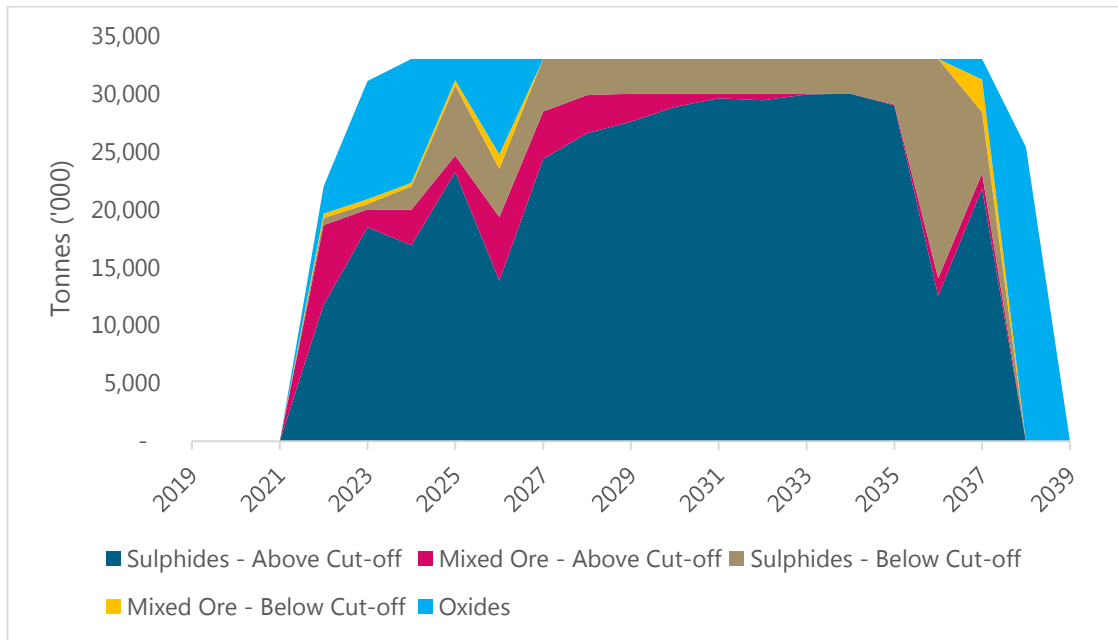
The Yandera Project will incorporate:

- A large and efficient open pit mine producing 33Mt of ore per annum, and a total of 540Mt over a 20-year life of mine (LoM), with an average stripping ratio of 1.36. The material will be mined from multiple areas, which will coalesce to form one large pit. A contractor-based mining strategy has been applied, whereby the mining fleet is supplied and operated by a mining contractor for an operating cost premium per tonne of material mined. Large, modern, highly efficient, and cost-effective equipment suites will be used for the mining activities.



**Figure 1-1: Mining Profile**

- A split processing facility whereby the Run-of-Mine (RoM) ore will be transported to the mine precinct area, crushed and milled before being transported to the coastal facility via a 146km slurry pipeline. The pumped material will be processed at the Cape Rigny coastal facility through flotation plants producing copper (Cu) and molybdenum (Mo) concentrates. The coastal facility will produce approx. 320ktpa of Cu concentrate (28% Cu grade) containing approx. 100ktpa of Cu metal, exported from a wharf at the site. The tailings are disposed of via a deep-sea placement pipeline.



**Figure 1-2: Plant Feed Profile**

- Certain local and regional infrastructure items have been classified as National Infrastructure (NI) such as roads, camps, wharf facilities and other services that would be beneficial to the country, its people and economy. These collectively account for approximately USD197m in capital expenditure, which is expected to be funded outside of the Project. Era is actively engaging with the PNG government to develop this philosophy.
- Power will be supplied by an independent producer through an “over-the-fence” arrangement, whereby all generation and transmission costs, both capital and operating cost, will be incorporated into a set tariff capped at 13c/kWh.

## 1.3 Conclusions

Following a very thorough PFS study assessment of the Yandera Project, the following conclusions have been reached:

- The Yandera orebody is well defined and understood, and hosts a large copper resource of almost one billion tonnes of ore.
- The optimized mining pit shell contains approximately 540Mt of probable ore reserve that is practically and economically minable.
- Reasonable and appropriate technical options and scenarios have been considered in selecting and evaluating the current project design.
- Apart from the clearly demonstrated value to potential investors, the PNG economy and people will benefit greatly from the large in country spend and infrastructure development, as well as the significant tax, royalty and export earnings that will accrue.
- No unacceptable or unmanageable risks have been identified in the Project, nor any material technical, environmental or socio-political obstacles to project development.



- Several areas of potential optimization and additional value have been identified to pursue going forward, including:
  - Increased value and LoM through resource-to-reserve upgrades around the current pits.
  - Improved recoveries through further metallurgical test work and analysis.
  - Increased value through mining schedule optimization.

Hence, it is recommended that the Yandera Project progress to the DFS stage, during which the designs and cost estimates will be developed further to improve confidence and reduce risk. The DFS will prepare the Project for permitting and execution.

## 1.4 Study Responsibilities

The responsibilities for conducting studies required to complete the PFS and the project report are as follows:

- Advisian – overall report and PFS organization, mineral processing and metallurgical testing, mineral reserve estimates, mining methods, recovery methods, project infrastructure, rock mechanics and open pit geotechnical studies, capital and operating costs. Advisian has coordinated and peer reviewed this Report and its content.
- SRK – the overall geological setting and mineralization, sample preparation, reliance on other experts, analyses and security, exploration, deposit types and mineral resource estimates, drilling and data verification.
- Fraser McGill- financial modelling and valuation.
- Coffey – environmental studies, permitting and social or community impact, relevant information concerning an adjacent property and analyses on the climate and length of the operating season.
- BRASS Engineering – ore slurry pipeline transportation study and Deep-sea Tailings Placement (DSTP) study.
- Era – property description and location, description of the prior ownership of the property and ownership, any significant historical mineral resource and mineral reserve estimates.

## 1.5 Property Description and Ownership

The Yandera Project is located in the southwestern part of the Madang Province in the central highlands of PNG at an elevation ranging from 1,500m to 2,400m above mean sea level in steep terrain with high annual rainfall. The Project is located at longitude 145.12°E and latitude 5.75°S, which is about 95km southwest of the city of Madang as shown in Figure 1-3 and Figure 1-4 below.

Access to the site is predominantly by helicopter. Road access to the site is under development as a refurbishment and extension of a pre-existing road.

Era holds two non-contiguous Exploration Licences (EL): EL 1335 (Yandera) and EL 1854 (Lila/Cape Rigny). The total tenement package covers 269.4km<sup>2</sup>, but the vast majority of work to date and all the resources published on the property have been within EL 1335.



Yandera owns 100% of the exploration tenements. There are no other royalties, back-in rights, or other encumbrances on the property, except the Mining Lease royalty to the government of PNG, which is 2% of the net proceeds of sale of minerals and a 0.25% production levy.

In the EL agreements, the state (PNG) reserves the right to purchase up to 30% equity interest in any mineral discovery arising from the EL. The purchase price would include up to a 30% cumulative share of all exploration and development cost to-date.



Figure 1-3: Project Location Map



Figure 1-4: Exploration Tenure Map





## 1.6 Geology and Mineralization

Yandera is an igneous, intrusive-hosted, structurally controlled Cu porphyry system with ancillary Mo and gold (Au) comprised of a series of adjacent, vertically oriented deposits along recognized structural trends. Mineralization is concentrated in several deposits, namely, Imbruminda, Gremi, Omora, Gamagu and Dimbi. Imbruminda, Gremi, and Omora are contiguous and separated from Dimbi by a low-grade, central, silica-rich zone, which is bounded on three sides by high angle faults. The bulk of the mineralization is adjacent to these major structures on a northwest-southeast trend. Locally, north-northeast-trending cross faults bound mineral domains and reflect the structural complexity of the district.

Mineralization is related to multiple pulses of intrusive activity and hydrothermal alteration/mineralization. Elevated grade has spatial correlation with late dacite intrusions and polymictic breccias with over-printing phyllic alteration. Broad tabular zones of copper mineralization extend from surface to depths of over 500m and have been drill-defined to a strike length of over 5km.

All the Yandera porphyry-hosted Cu deposits lie within the Miocene Bismarck Intrusive complex. This complex is a batholith comprising predominantly granodiorite with lesser amounts of gabbro and quartz monzogranite. The northwest-striking Ramu Fault Zone and the upthrust sediments and ophiolites of the Ramu Ophiolite Complex bound the Bismarck Intrusive complex to the north. There is an interpreted flexure in the Ramu Fault Zone to the north of Yandera, which may have played an important role controlling extension and mineralization at Yandera.

Early interpretations suggested a major shift in plate movement north of PNG at the time of intrusive emplacement when the major principal stress direction changed from predominantly left-lateral strike slip to a stress field more dominantly compressive. The strike-slip movement is interpreted to have arranged the mineral deposits in a northwest-southeast orientation, while compression and subsequent relaxation appear to have had the most pronounced impact on the mineralization timing.

## 1.7 Status of Exploration, Development and Operations

The Yandera Project has completed the PFS stage of development. EL 1335 is fully covered by regional, airborne geophysics including airborne magnetics and radiometrics. Surface mapping and surface geochemistry to define drilling targets have supplemented the airborne surveys.

Era completed a drilling programme in 2016 that added 50 drillholes and 10,099m of drilled length to the project database. Most of these drillholes (43 holes) were for resource infill; seven were for geotechnical engineering purposes and were not assayed in time to be included in this resource estimate. Drill core is preserved in secure, on-site core storage facilities at the Yandera Camp, Frog Camp and Peure.

No mining has been carried out to date apart from two shallow excavations for bulk metallurgical samples carried out in the Gremi deposit. The main base of operations for exploration is currently at Frog Camp with lesser support from Yandera Camp. Until the access road is upgraded, helicopter-assisted mapping, surface sampling and core drilling continue at the site.

A geotechnical drill campaign has been conducted in 2017 to inform better the pit slope designs and certain civil designs as the Project progresses.



## 1.8 Mineral Processing and Metallurgical Testing

The ore body at Yandera has been the subject of a number of historical investigations focussed on processing the Cu sulphide rich zones of the porphyry. Some additional test work was conducted in support of the current study. This was limited to bridging gaps in sample representativeness, and to test the robustness of the selected flowsheet for Dimbi sulphide and for oxide and mixed ores.

Bench-scale test work conducted on sulphide ore has demonstrated that a saleable concentrate containing at least 28% Cu can be produced. No deleterious elements are expected whilst Cu recoveries in excess of 93% are possible. Oxide ore is recoverable to a lesser extent by flotation, and benchmarking has been selected as the primary source of recovery data for this study.

### 1.8.1 Sulphide Ore

Comminution test work was conducted on 61 borehole core samples, representing the various target zones, lithological variation, as well as variation with depth. The samples tested demonstrated that the ore hardness was in the medium to hard range, and medium to high in terms of competence. The samples tested had a low abrasion index.

The standard process route for porphyry ores is flotation with multi-stage cleaning. At Yandera, this is followed by separation of Cu from Mo and a multistage Mo cleaning and regrind circuit. Test work results indicated that Cu rougher flotation with xanthate collectors had very fast kinetics. Cu recovery was found to be grind insensitive in the size range considered. A grind of 80% minus 150 microns was found to be optimal.

The key metallurgical drivers for extraction of Cu from the sulphide ore are variability in Cu mineralogy and pyrite content (as the major gangue species). It has been established that the predominant Cu species in the various target zones are chalcopyrite and bornite in varying proportions, and this will govern, along with the pyrite content, the final copper concentrate grade attainable for a target mass pull. This could range from 40% to 20%.

The metallurgical programme conducted to date has proven that pyrite can successfully be depressed in the cleaner stages without significant impact on Cu or Mo recoveries. Au recovery was impacted in some cases, possibly because of association with pyrite. Suitability of the flowsheet for treatment of Dimbi ore, which was not part of the previous FS programme, was confirmed.

The metallurgical studies conducted to date indicate that a thorough understanding of the Cu mineralogy, as well as pyrite distribution across the ore body is essential for prediction of metallurgical performance over the LoM. The distribution of pyrite will dictate the optimal reagent suite. This is one of the major objectives of test work to be conducted as part of the DFS.



## 1.8.2 Oxide Ore

During a “StepWise” study by Advisian in 2016, it was recommended to include the oxide material as a potential reserve using flotation with estimated recoveries of approximately 60%. Confirmatory test work conducted in 2017 was limited and inconclusive, with the presence of some non-floatable copper-bearing mineral species in the form of clays, silicates and iron oxides detected, which could have an impact on recovery by flotation. The distribution of non-floatable copper-bearing minerals is not clearly understood at present and hence benchmarked recoveries of 55% have been applied. Further test work, including mineralogical characterisation of oxide and mixed ores, is planned during the DFS to understand the potential of the oxide material better.

## 1.9 Mineral Resource Estimate

The estimate of Measured and Indicated Resources for the Yandera deposit in the highlands of PNG is approximately 728Mt at a grade of 0.39% CuEq, with contributions to the CuEq coming from low-grade Mo and Au. There is an additional 230Mt at 0.32% CuEq reported as Inferred Resource. The resource is reported within a potentially mineable open pit configuration. The majority of the resource is in sulphides, which recent metallurgical test work demonstrates is recoverable by conventional flotation to produce a concentrate. Of the total resource, approximately 8% of the tonnes reside in oxide, which is expected to have lower recoveries for each of the economic metals. Exploration is ongoing at Yandera, as is further metallurgical, geotechnical and environmental characterization to advance the Project.

The Mineral Resource Statement, with an effective date of December 15, 2016, is presented in Table 1-1. The resource has been reported as a total, and as oxide and non-oxide components, as these material types will have different metallurgy and will have different recovery characteristics and costs.

**Table 1-1: Mineral Resource Statement for the Yandera Copper, Molybdenum, Gold Deposit, Madang Province, Papua New Guinea [0.15 CuEq (%) Cut-off] SRK Consulting, December 15, 2016**

Zone	Classification	Mass	Metal Grades				Contained Metal				
		(kt)	CuEq (%)	Cu (%)	Mo (%)	Au (ppm)	CuEq (kt)	Cu (kt)	Mo (kg)	Au (kg)	Au (koz)
Total Resource	Measured	196,480	0.46	0.38	0.01	0.10	895	742	26	18,878	607
	Indicated	530,406	0.36	0.31	0.01	0.06	1,911	1,652	46	30,636	985
	<b>Measured &amp; Indicated</b>	<b>726,886</b>	<b>0.39</b>	<b>0.33</b>	<b>0.01</b>	<b>0.07</b>	<b>2,805</b>	<b>2,393</b>	<b>73</b>	<b>49,514</b>	<b>1,592</b>
	Inferred	227,108	0.32	0.29	0.00	0.04	728	663	11	8,080	260
Oxide Resource	Measured	19,529	0.42	0.37	0.01	0.12	82	72	1	2,321	75
	Indicated	44,203	0.36	0.33	0.01	0.07	159	146	2	2,902	93
	<b>Measured &amp; Indicated</b>	<b>63,733</b>	<b>0.38</b>	<b>0.34</b>	<b>0.01</b>	<b>0.08</b>	<b>242</b>	<b>219</b>	<b>4</b>	<b>5,223</b>	<b>168</b>
	Inferred	18,443	0.27	0.26	0.00	0.03	51	48	1	599	19
Non Oxide Resource	Measured	176,951	0.46	0.38	0.01	0.09	812	669	25	16,557	532
	Indicated	486,203	0.36	0.31	0.01	0.06	1,752	1,505	44	27,735	892
	<b>Measured &amp; Indicated</b>	<b>663,153</b>	<b>0.39</b>	<b>0.33</b>	<b>0.01</b>	<b>0.07</b>	<b>2,564</b>	<b>2,175</b>	<b>69</b>	<b>44,291</b>	<b>1,424</b>
	Inferred	208,665	0.32	0.29	0.01	0.04	677	615	11	7,481	241





## 1.10 Mineral Reserve Estimate

The Probable Mineral Reserves Estimate of the Project as at 27 November 2017 is summarized in the table below. The Mineral Reserves were determined in accordance with the requirements of the NI 43-101 Standards.

**Table 1-2: Total Probable Mineral Reserves Estimate**

Material	Probable Reserve Ore (kt)	Cu Grade (%)	Mo Grade (%)	Au Grade (ppm)	Pit Estimates (kt)
Oxide Ore	60,482	0.3365	0.0057	0.0819	
Sulphide Ore	441,040	0.3325	0.0107	0.0683	
Transitional Ore	38,975	0.3625	0.0107	0.0885	
<b>Total Ore</b>	<b>540,497</b>	<b>0.3351</b>	<b>0.0102</b>	<b>0.0713</b>	
<b>Total Waste</b>					<b>733,772</b>
<b>Total</b>					<b>1,274,269</b>
<b>Stripping Ratio</b>					<b>1.36</b>

## 1.11 Mining Methods

Conventional open pit mining methods consisting of drilling, blasting, loading and hauling will be employed at Yandera mine. Contractor mining was determined to be more viable than an owner-operated fleet during the financial analysis of the PFS.

For the owner-operated fleet option, Atlas Copco DM30II (or similar class) drill rigs, were costed for drilling production holes in ore and waste. Atlas Copco FlexiRoc (or similar class) drill rigs were costed for drilling holes required for perimeter control. A combination of buffer blasting and presplitting is recommended as a perimeter control measure to ensure stability of the final highwalls around the perimeter of the pit.

Blasted material will be loaded using Komatsu P&H4100 (or similar class) electric rope shovels. The shovels will load the material into Belaz 75602 (or similar class) diesel-electric dump trucks which will haul ore to the primary crusher location or ore stockpiles and waste to the waste rock dump.

The primary mining activities will be supported by ancillary activities including the following:

- Bench preparation.
- Pit dewatering.
- Dust suppression.
- Haul road construction and maintenance.
- General housekeeping.

The mine was designed to produce 30Mtpa of above cut-off grade sulphide ore. An additional 3Mtpa will be processed from the below cut-off grade sulphide ore stockpile or from the oxide ore stockpile when the sulphide ore sources are insufficient.



## 1.12 Geotechnical Investigation

A detailed geotechnical and hydrological study formed part of the PFS. The geotechnical engineering process adopted is in keeping with the methodology suggested by Read and Stacey (2009).

A geological block model, lithological model, structural data, dedicated geotechnical information as well as geohydrological data were available to develop a geotechnical characterization model that is adequate for a PFS-level of study.

During the study, the design of the waste rock dump was completely changed from a rock-fill earth wall to a valley infill dump due to economic considerations.

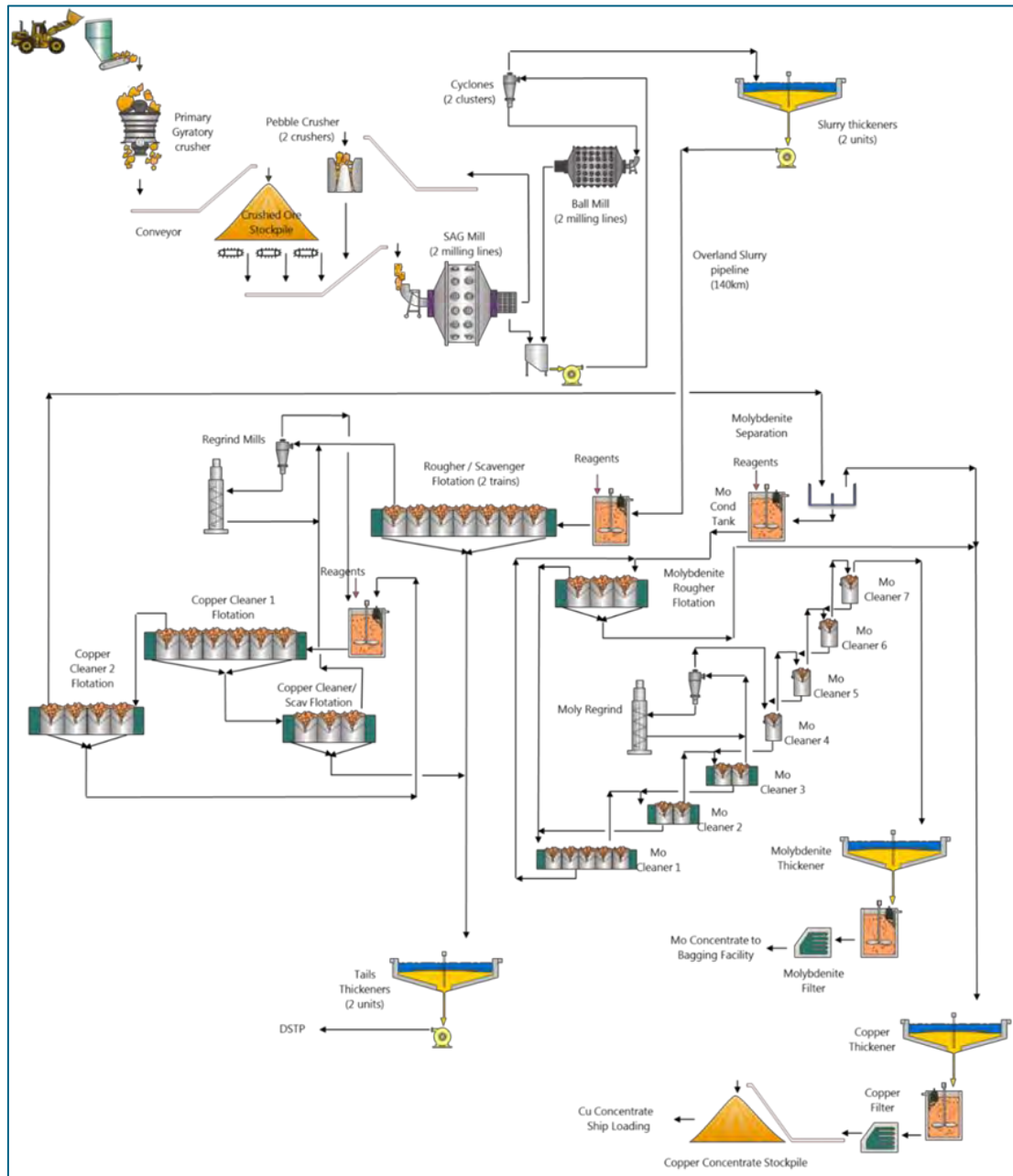
The terrain in which mining will take place is challenging with very steep natural slopes resulting in high cut slopes in weak ground. The extent of the slopes cut into overburden was only defined after the mine design was completed. Consequently, the design and design optimization of the cut slopes in the oxidized zone and rock and soil will have to be revisited in detail during the DFS. Similarly, the slope and possible slope support for all the road cut slopes (whether main access road or internal mine roads) will have to be re-assessed in detail.

## 1.13 Recovery Methods

The flowsheet selected for processing ore at Yandera is a conventional concentrator comprising milling and flotation to produce two concentrate streams, i.e. a copper concentrate and a molybdenum disulphide concentrate.

The major unit operations consist of:

- Crushing.
- Two stage milling (SAG and Ball milling) incorporating pebble crushing.
- Slurry dewatering and overland transfer by pipeline.
- Bulk rougher and scavenger flotation.
- Copper concentrate regrind ahead of two stage cleaning and a cleaner scavenger circuit.
- Molybdenum disulphide rougher circuit.
- Seven stage molybdenum disulphide cleaner circuit incorporating concentrate regrind.
- Concentrate dewatering and filtration/ drying.
- Tailings dewatering and disposal by DSTP.



**Figure 1-5: Processing Schematic**

The process plant is designed for a throughput of 30Mtpa, but is capable of a throughput of 33Mtpa. Treatment of ore arising from the Yandera Project will be effected in two locations. The comminution circuit is located at the Yandera mine site. The Yandera milling plant is accessible by road from Madang at a distance of 120km. Milled ore slurry is thickened and transferred by overland pipeline over a distance of 146km to the coastal facility for concentration by flotation.

The flotation circuit will be located at the coastal facility close to the DSTP outfall point and concentrate export wharf. A barge from Madang, a barging distance of 54km, accesses the coastal facilities.



## 1.14 Project Infrastructure

The Project requires both regional and local infrastructure. Facilities are required at Yandera to support mining and processing activities. The balance of processing will take place at the flotation plant located at Cape Rigny. The facilities at both locations include associated support infrastructure and utilities. The Yandera to Cape Rigny link comprises the ore slurry pipeline, access roads and power transmission lines.

Regional infrastructure includes the following:

- Mine access roads to Yandera.
- Barging facilities at Cape Rigny (Connecting to Madang).
- Wharf facility at Cape Rigny.
- Flotation Plant slurry transfer pipeline.
- Telecommunication and internet services.

### 1.14.1 Mining and Milling Precinct Area

The infrastructure in this area consists of electrical distribution sub-stations, ore and waste handling systems, milling plant, water supply and dewatering systems, workshops and refuelling facilities, security, stores and warehousing, administration building and change room, control room and medical station, waste handling facilities, waste rock dump, fire water pumping system, potable water treatment plant and storage tank, sewage treatment and the Yandera accommodation camp.

### 1.14.2 Mining Pit Area and Waste Rock Dump

The infrastructure required in the mine pit and waste rock dump area consists of initial haul and access roads from the milling and infrastructure precinct to the various pits, hill-top access roads for the various pits, pit dewatering systems and the electrical reticulation for supplying the trolley assist system, mining and dewatering loads. The mine site layout is shown in Figure 1-6 below.

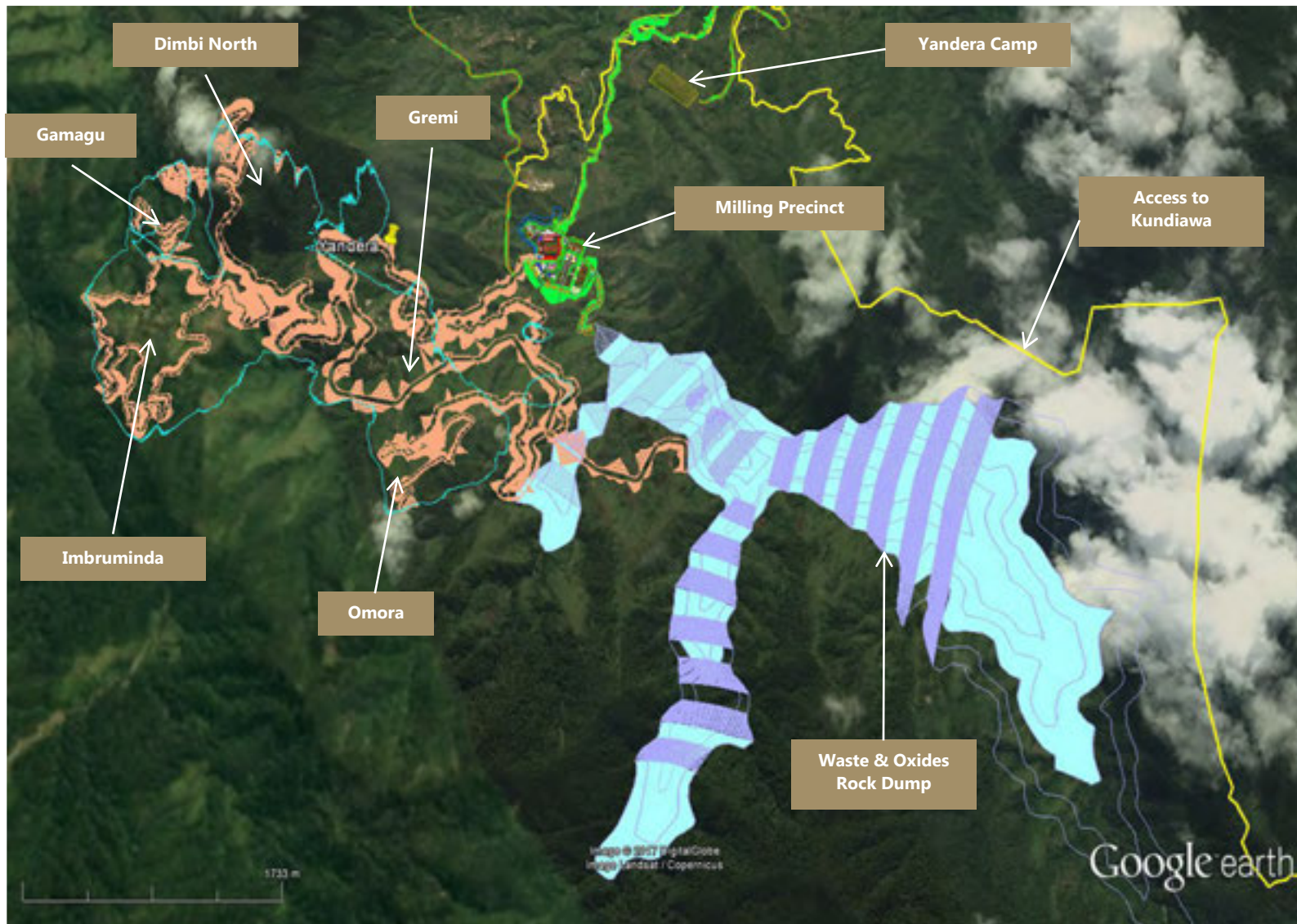


Figure 1-6: Yandera Mine Site Layout



### 1.14.3 Coastal Facilities

The infrastructure in this area consists of barge launching and loading facilities wharf facility, the flotation plant, the DSTP system and the Cape Rigny accommodation camp. The layout of the coastal facilities is shown in Figure 1-7 below.



Figure 1-7: Coastal Facilities Conceptual Layout

## 1.15 Environment Studies and Permitting

### 1.15.1 Environmental Studies

A significant amount of information on the biophysical and social environment has been collected over the past 10 years. Most of the work was conducted between 2007 and 2012 to support a previous project Environmental Impact Statement (EIS). Although the EIS was not finalized, the surveys produced a large amount of data and information relevant to the current project and substantially more than would usually be available at the PFS stage of similar projects. Data gathering will continue, and environmental considerations addressed through the ongoing environmental monitoring and approved EIS programmes.

Environmental and social studies conducted to date, along with the understanding of issues faced by similar projects in PNG, have identified the following key areas for consideration:

- Management of mine material on land -- the ore and waste rock material may be potentially acid forming and will be managed during operations and post-closure. A geochemical assessment of waste rock and ore is currently underway and will inform potential management options.
- Risk and risk-perception associated with DSTP - DSTP has the potential to result in biophysical impacts to the marine environment. As part of the EIS works programme, a DSTP impact assessment will be conducted. This assessment will address the potential for upwelling, and will characterize the behaviour of the DSTP discharge including modelling the migration pathway and area of deposition.



- Impacts to the nearshore marine environment – sediment and contamination control measures will be proposed and required to minimise impacts in the nearshore marine environment. Studies of nearshore sedimentation and fringing reef condition and a nearshore marine impact assessment are proposed as part of the EIS programme.
- Water and soil management – the water quality and condition of waterways require focus and management controls with a view to reducing sediment runoff from disturbed areas and sedimentation within watercourses. Minimizing disturbance footprints, using competent rock material for construction of a stable waste rock dump, and installing adequate drainage diversions and erosion controls are key measures that will be implemented in the Project.
- Rehabilitation of the mine site – the long-term integrity, end use, closure and rehabilitation of disturbed areas will be assessed further as the Project progresses. The pit voids and the waste rock dump will need to be monitored and managed, as required, in perpetuity. The EIS works programme will include the development of a conceptual plan for the successful and safe rehabilitation and closure of the mine, with closure objectives developed in consultation with stakeholders.
- Dust, noise, vibration, and gaseous emissions – the Project will generate noise and vibration during construction and operations, primarily at the mine site. The Project may generate dust (wherever the ground surface is disturbed); gaseous emissions from the concentrator plant and exhaust gases from haul trucks and other equipment. The effects of noise, vibration and air emissions on the general safety and amenity of residents and other sensitive receptors in the project area will need to be managed through implementation of standard management measures such as dust suppression, noise suppression devices installation, where required, and ongoing consultation with local communities.
- Terrestrial biodiversity impacts – project activities could affect habitats of conservation concern and/or threatened species and a range of management measures will be implemented to address biodiversity issues. Such measures include locating infrastructure within existing easements and disturbed areas and reducing the level of vegetation clearance and disturbance required for the Project.
- Socio-economic issues – the Project could result in a range of socio-economic impacts. A Social Impact Assessment (SIA) will be prepared for the Project and included in the EIS. Further surveys to characterize potentially affected communities are proposed as part of the EIS programme.

## **1.15.2 Permitting**

### **1.15.2.1 Permitting Requirements**

The Mining Act 1992 and the Environment Act 2000 primarily regulate the assessment, approval and development of the Project. Requirements under these acts are summarized below.

### **1.15.2.2 Mining Act 1992**

The Project would be required to operate under a Special Mining Lease (SML), which is generally issued to the exploration licence holder for large-scale mining operations. The exploration licence holder must also be a party to a Mining Development Contract with the State.



A special mining lease may be granted for a term not exceeding 40 years and may be extended for periods not exceeding 20 years. The holder of an SML must pay a royalty to the State equivalent to 2% of the net proceeds of sale of minerals.

Before the granting of an SML, the Minister is required to convene a development forum to consider the views of the persons and authorities whom the Minister believes will be affected by the granting of the SML. The forum should include representatives from the applicant for the SML, affected landholders, and the national and provincial government.

The application for an SML will need to contain a proposal for development and typically includes the following components/steps:

- Feasibility and landownership study.
- Business development, supply and procurement plan.
- Employment and training plan.
- Negotiation of a mining development contract with the State.
- Applications for lease for mining purposes and mining easement, as required.
- Mining Warden's hearings for all tenements applied for.
- Negotiation of a compensation agreement with landowners.
- Participation in a development forum with all levels of government and landowners to negotiate how the benefits of the Project will be distributed.
- Signing of a memorandum of agreement with all participants in the development forum.

### **1.15.2.3 Environment Act 2000**

The principal legislation for regulating the environmental effects of projects in PNG is the Environment Act 2000 (Environment Act). The act requires a proponent to obtain an environment permit for activities that have the potential to cause environmental harm. Activities are classified as Level 1, Level 2 or Level 3 based on their risk of causing environmental harm and each requires a different level of environmental and social assessment.

Level 3 activities, which include mining developments of the scale of the Project, have the highest risk of causing environmental harm. The granting of a Level 3 environment permit is subject to a comprehensive Environmental Impact Assessment (EIA), presented in an EIS. The Conservation and Environment Protection Authority (CEPA) reviews the EIS in consultation with the public.

The EIA process may be subject to amendments from the Environment (Amendment) Act 2014 once this statute comes into force. The key requirements of the EIS process under the Environment Act 2000 and the suggested amendments under the Environment (Amendment) Act 2014 include:

- Preparation and submission of an Environmental Inception Report (EIR).
- Preparation and submission of an EIS.
- A public review and referral phase.
- In-principle approval of the proposed activities by the Minister for Environment and Conservation.





The EIR for the Project was submitted to CEPA on 24 June 2016 (Coffey, 2016) and was approved on 2 August 2016. The report identified potential environmental and social issues associated with the Project and described the scope of the EIS, including specialist technical studies that will be carried out. Once the EIS is submitted and approval granted in principle, Era will need to apply to CEPA for an environment permit for a Level 3 activity.

The following controls will be implemented to manage the permitting process:

- Appointing an experienced lead environmental consultant to manage project approvals.
- Conducting frequent government and agency consultation.
- Implementing a stakeholder engagement plan.
- Ensuring close liaison between the lead environmental consultant and project engineers.
- Ensuring that comprehensive and scientifically defensible environmental and social studies are undertaken;
- Incorporating technical peer review throughout the EIS process.

## **1.16 Operating and Capital Costs**

### **1.16.1 Operating Costs**

An activity-based cost model was developed by Advisian to determine the working cost from first principles. The activity-based costing model uses the mine and process design criteria and production schedule inputs to derive cost rates for mining, processing and engineering activities. The derived rates are used in the model, and are driven by the production schedule to obtain the overall operating cost.

The costs are split between fixed costs, which are not dependant, and variable costs, which depend on the mined and treated ore and waste schedules.

The model categorises the total operating cost into the following six categories:

- Mining.
- Yandera Precinct.
- Milling Plant.
- Mill to Coastal Facilities.
- Coastal Facilities.
- General and Administration.

Each of these main categories consists of defined activities for which individual cost drivers are defined. The coastal facilities include the flotation plant, molybdenum circuit, DSTP and coastal facilities camp. The major contributors to the cost are the mining and the processing cost, which are described in more detail below.



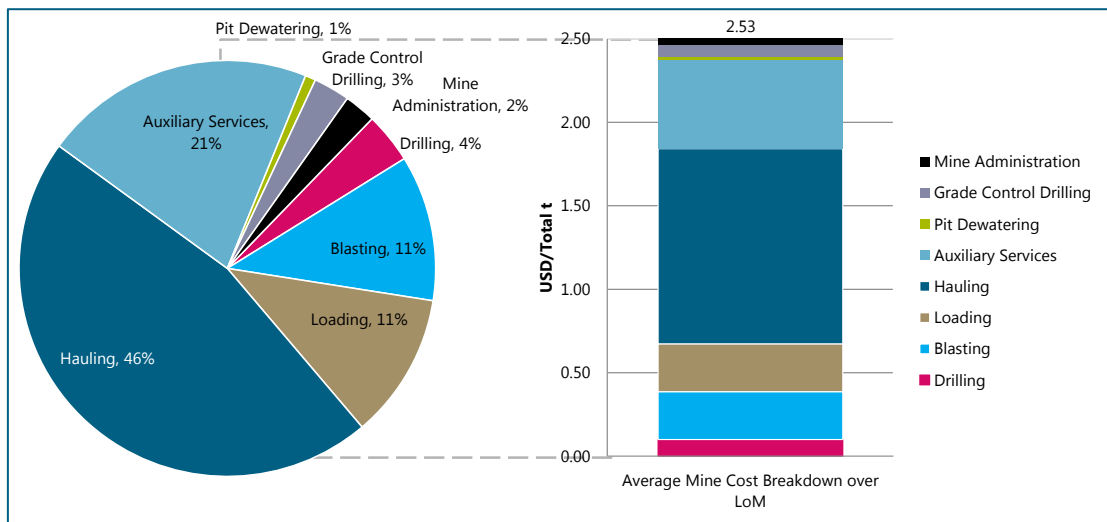
### 1.16.2 Mining Opex

The operating cost breakdown in Table 1-3 indicates the average main cost activities per total tonne mined (waste and ore) over the LoM for the contractor-operated mine. These main activities were broken down into distinct activities each with its own unit of measure. The average total cost amounts to USD2.53 per total tonne mined over the LoM, which relates to USD5.87 per milled tonne.

**Table 1-3: Mining Operating Cost Breakdown**

Cost Item	Cost [USD/mined t]	Cost [USD/milled t]
Drilling	0.10	0.23
Blasting	0.29	0.67
Loading	0.29	0.66
Hauling	1.19	2.71
Auxiliary Services	0.53	1.24
Pit Dewatering	0.02	0.05
Grade Control Drilling	0.07	0.17
Fixed Costs	0.06	0.14
<b>Total</b>	<b>2.53</b>	<b>5.87</b>

The contribution to the operating cost by each cost element over the LoM is illustrated in Figure 1-8.



**Figure 1-8: Mining Cost Contribution by Element**



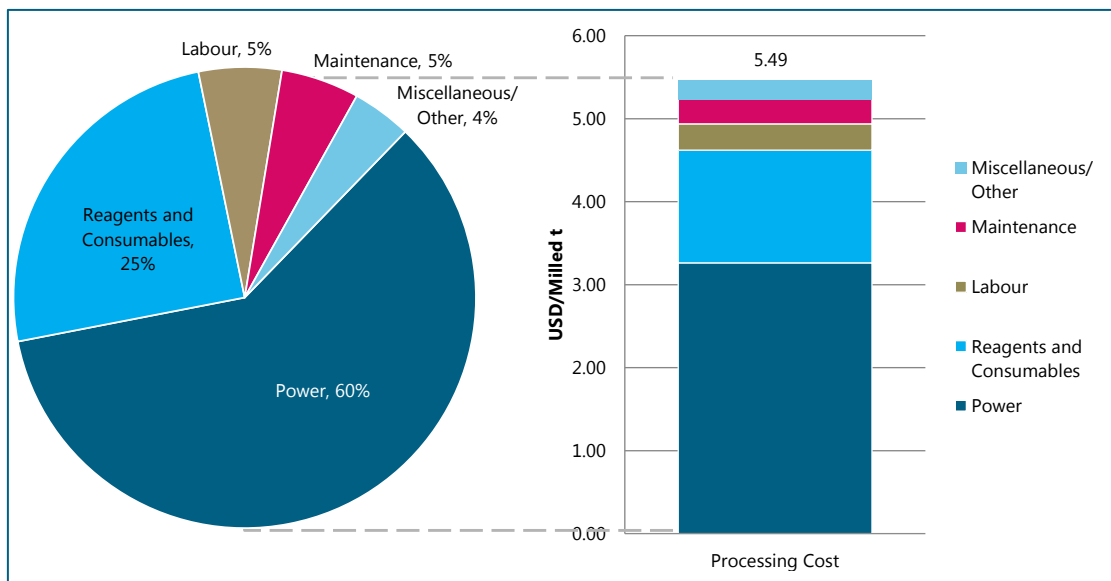
### 1.16.3 Processing Opex

The summary of the milling, flotation and molybdenum circuit is described in Table 1-4. The total cost amounts to USD5.49 per milled tonne at a throughput of 30 to 33Mtpa of sulphide ore.

**Table 1-4: Processing Cost Summary**

Processing Activity	Item	Cost [USD/t]
Milling Plant and Mine Support Infrastructure	Power	2.98
	Labour	0.10
	Maintenance	0.22
	Consumables	1.01
	Miscellaneous/ Other	0.11
<b>Milling Plant Sub-Total</b>		<b>4.42</b>
Flotation Plant	Power	0.33
	Labour	0.19
	Maintenance	0.08
	Reagents and Consumables	0.34
	Miscellaneous/other	0.11
<b>Flotation Plant Sub-Total</b>		<b>1.04</b>
Mo Circuit	Power	0.01
	Maintenance	0.00
	Reagents and Consumables	0.01
<b>Mo Circuit Sub-Total</b>		<b>0.03</b>
<b>Total Processing Cost</b>		<b>5.49</b>

A breakdown of the total processing cost is displayed graphically in Figure 1-9.



**Figure 1-9: Processing Cost Breakdown**



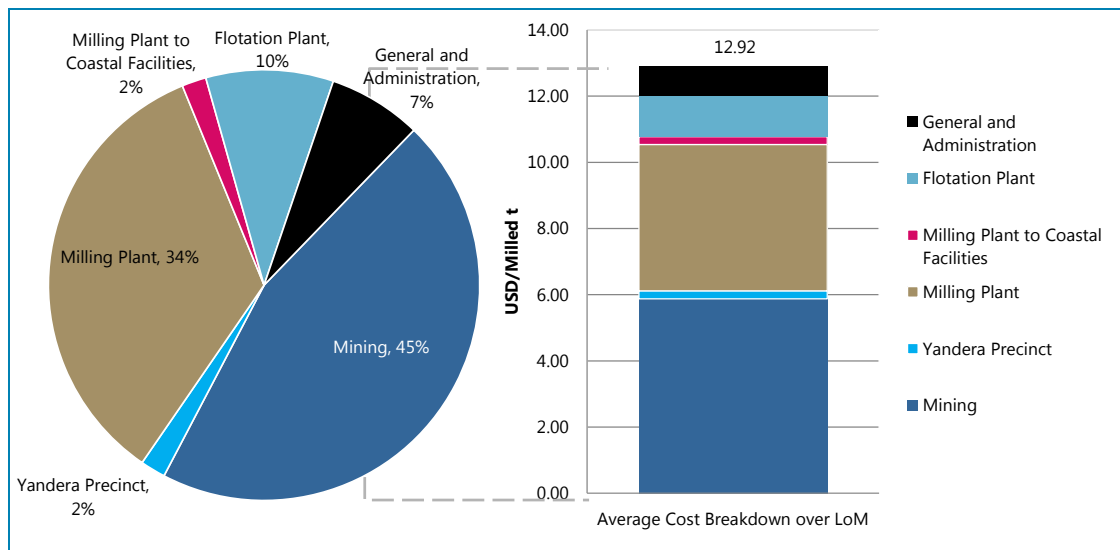
### 1.16.4 Opex Summary

The average total cost amount to USD12.92/milled tonne over the LoM as described in Table 1-5.

**Table 1-5: Operating Cost Breakdown**

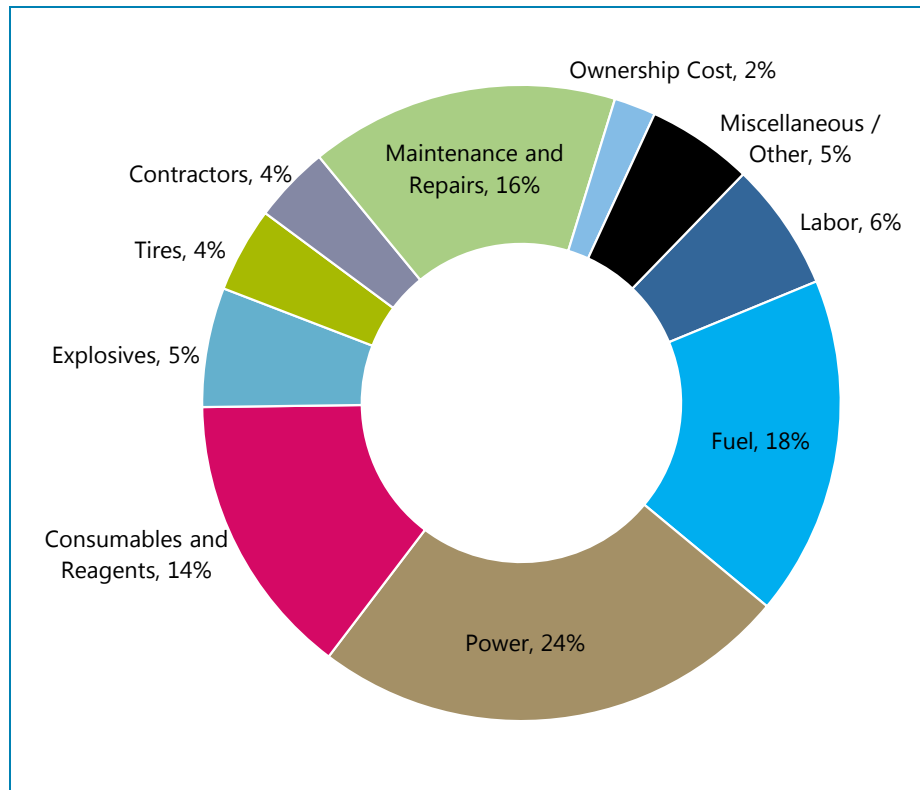
Cost Item	Unit	Cost [USD/t]
Mining	USD/milled tonne	5.87
Yandera Precinct	USD/milled tonne	0.24
Milling Plant	USD/milled tonne	4.42
Mill to Coastal Facilities	USD/milled tonne	0.24
Coastal Facilities	USD/milled tonne	1.24
General and Administration	USD/milled tonne	0.91
<b>Total Opex</b>	<b>USD/milled tonne</b>	<b>12.92</b>

The contribution to the operating cost by each cost element over the LoM is illustrated in Figure 1-10.



**Figure 1-10: Total Cost Contribution by Element**

Mining contributes most to the operating cost at 45% followed by the milling and flotation plant together contributing another 44%. A breakdown of the cost by sub-activity is described in Figure 1-11. The major contributors to the cost are power and fuel.



**Figure 1-11: Cost Breakdown per Sub-activity**

The Operating Expenditure (Opex) DNA was structured according to the following breakdown as indicated in Figure 1-12. The analysis uses cost per tonne milled to allow comparison between different categories. However, the mining cost breakdown is shown per mined tonne, as this is applicable to waste as well as ore (milled) tonnes.

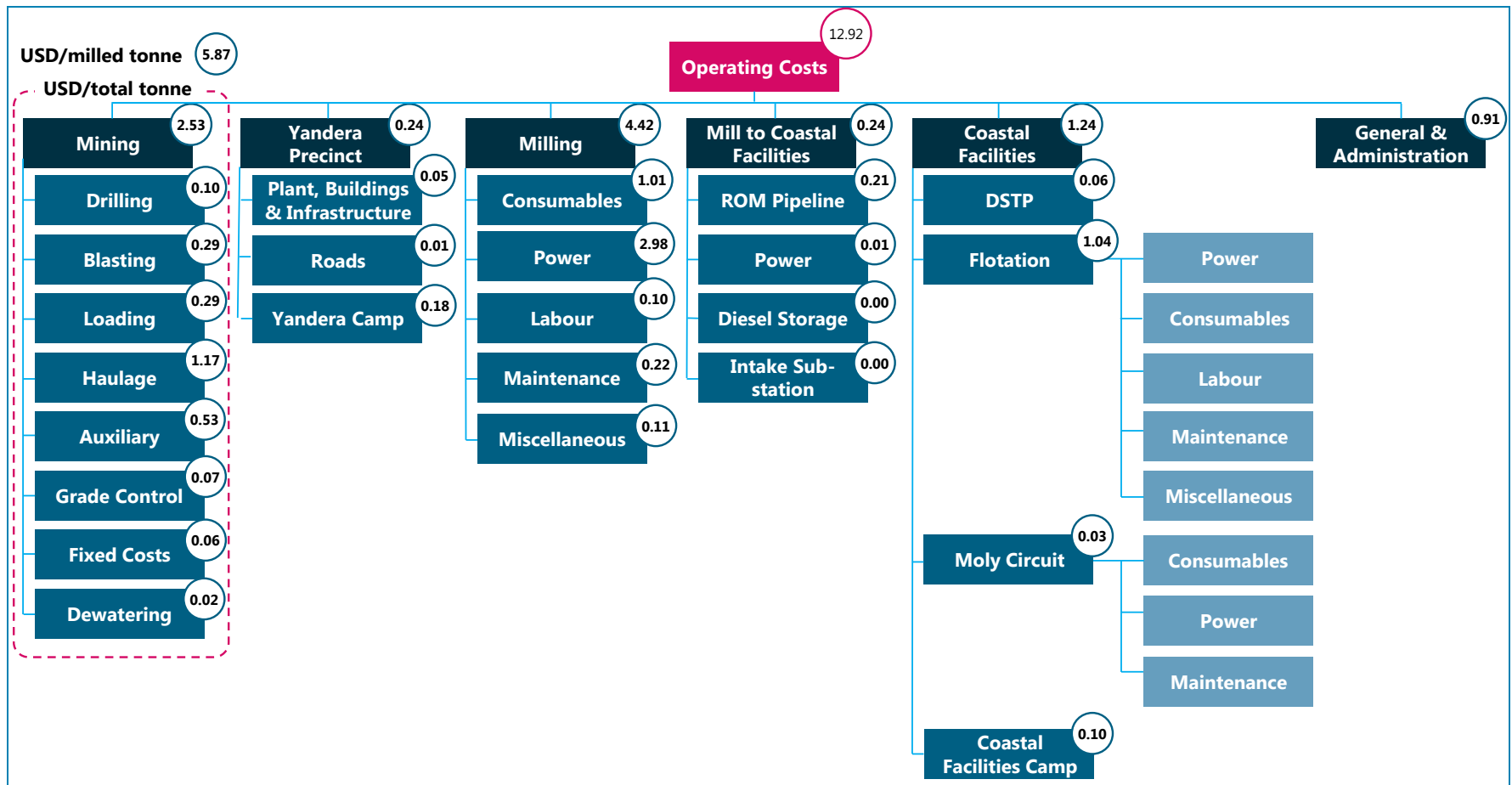


Figure 1-12: Opex DNA Summary (USD/milled tonne)



### 1.16.5 Capital Costs

The Capital Cost Estimate has been prepared according to the PFS level of accuracy guidelines (-15% +25%). A full all-inclusive estimate has been prepared. However, certain philosophies have been applied that reduce the project capital spend. These include a contractor mining approach, and an off balance sheet funding of selected National Infrastructure (NI) facilities

In the model, five main categories build up the total capital cost. These are:

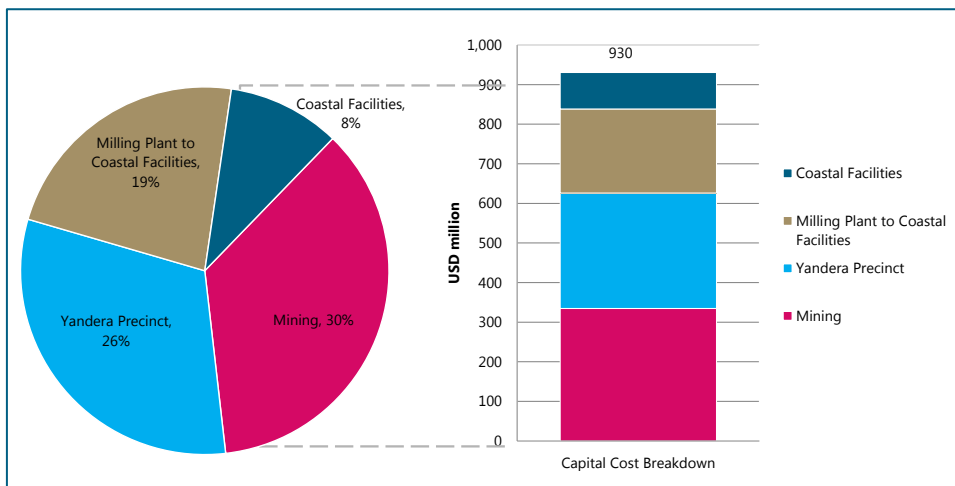
- Mining.
- Yandera Precinct.
- Milling Plant to Coastal Facilities.
- Coastal Facilities.
- National Infrastructure.

Table 1-6 illustrates the capital cost estimate for the major project areas including and excluding NI.

**Table 1-6: Capital Cost Estimate for Major Plant Areas**

Description	Project (excl. National Infrastructure)	Project including National Infrastructure
National Infrastructure		USD197m
Mining	USD335m	USD335m
Yandera Precinct	USD292m	USD305m
Milling Plant to Coastal Facilities	USD212m	USD305m
Coastal Facilities	USD92m	USD184m
<b>Total</b>	<b>USD930m</b>	<b>USD1,128m</b>

The contribution to the capital cost by each cost element over the LoM is illustrated in Figure 1-13. The mining capital is based on a contractor-operated mine and excludes the mining fleet capital.



**Figure 1-13: Total Capital Cost Contribution by Element**



The capital cost estimate excluding the mining fleet has been prepared in the project DNA structure shown in Figure 1-14.

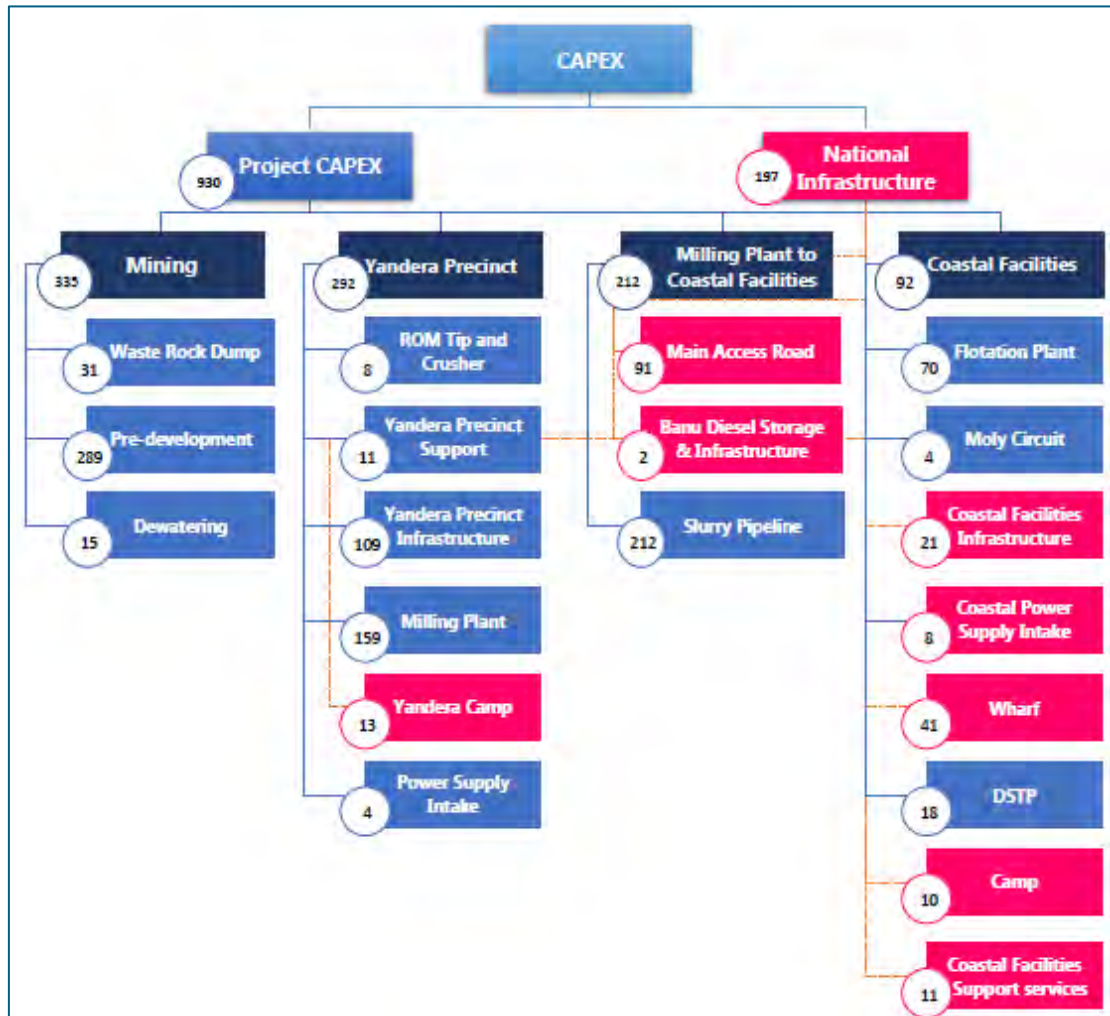


Figure 1-14: Project DNA Structure (USD)

## 1.17 Financial Analysis

The Yandera Project is expected to realise an NPV and IRR of USD1,038m and 23.5% respectively, in real terms. A capital investment of USD930m is required, which will be paid back after 5 years and 8 months.

Four valuation scenarios were created, as shown in Table 1-7:

- Project, excluding NI.
- Project, including National Infrastructure (NI).
- Applying spot commodity prices, excluding NI (Spot).
- Applying spot commodity prices, including NI (Spot + NI).





**Table 1-7: Valuation Results**

Valuation Metric	UoM	Project	Project + NI	Spot	Spot + NI
<b>NPV</b> <sub>7.8%</sub> (Real)	USD million	<b>1,038</b>	832	654	441
<b>IRR</b> (Real)	%	<b>23.5</b>	18.6	17.6	13.5
<b>Payback</b> (Real)	Years	<b>5yrs 8mths</b>	6yrs 6mths	8yrs 0mths	9yrs 4mths
<b>Project Capital</b>	USD million	<b>930</b>	1,128	930	1,128
<b>Cumulative Maximum Negative Cash Flow</b> (Nominal)	USD million	<b>896</b>	1,101	896	1,101
<b>C1 Cash Cost – LoM</b> (Real)	USD/lb	<b>1.99</b>	2.03	2.09	2.13
<b>C1 Cash Cost – First 5 years</b> (Real)	USD/lb	<b>2.20</b>	2.23	2.29	2.33
<b>Reserve</b>	million tonnes	<b>540</b>	540	540	540
<b>Cu Grade</b> (LoM Average)	%	<b>0.34</b>	0.34	0.34	0.34
<b>Au Grade</b> (LoM Average)	g/t	<b>0.07</b>	0.07	0.07	0.07
<b>Mo Grade</b> (LoM Average)	ppm	<b>102</b>	102	102	102
<b>Strip Ratio</b> (LoM Average)	ratio	<b>1.36</b>	1.36	1.36	1.36



## 2 Introduction

---

### 2.1 Issuer

This Report was compiled for Era, a Canadian-domiciled mineral resource company focused on, exploration and development of a base metal deposit.

### 2.2 Terms of Reference and Purpose of this Report

Era requested WorleyParsons RSA, trading as Advisian (Advisian), to complete an Independent Technical report for the Yandera Project.

The quality of information, conclusions and estimates contained in this Report is consistent with the Pre-feasibility Study (PFS) level of accuracy based on:

- i) Information available at the time of preparation.
- ii) Data supplied by outside sources.
- iii) Use of information.
- iv) The assumptions, conditions, and qualifications set forth in this Report.

This PFS report is intended for use by Era subject to the terms and conditions of its contract with WorleyParsons RSA and relevant securities legislation. The contract permits Era to file this PFS as a Technical Report with Canadian securities regulatory authorities pursuant to NI 43-101, Standards of Disclosure for Mineral Projects. Except for the purposes legislated under provincial securities law, any other uses of this Report by any third party is at that party's sole risk. The responsibility for this disclosure remains with Era. The user of this document should ensure that this is the most recent Technical Report. This Report provides mineral resource and reserve estimates and a classification of resources and reserves prepared in accordance with the Canadian Institute of Mining (CIM) Metallurgy and Petroleum, Standards on Mineral Resources and Reserves: Definitions and Guidelines, May 10, 2014.

The intentions of the report are to provide sufficient confidence that further studies should be undertaken to improve the confidence level of the Project and the economic outcome further.

### 2.3 Sources of Information

Various sources and information as listed in Section 27 were used to support the preparation of the Report.

The Independent Authors of this Report have used the data provided by the representatives and internal experts of Era. This data has been derived from historical records for the area as well as information currently compiled by the operating company, Era.



## 2.4 Involvement of the Qualified Person and Personal Inspections

- J.B. Pennington, M.Sc. C.P.G., is the QP responsible for background, geology, exploration, and environmental Sections 2, 3, 4 through 9, 20, 27, and 28, and co-authorship of resource geology and modelling Section 14, and portions of Sections 1, 25, and 26 summarized therefrom, of this Technical Report.
- SRK's J. B. Pennington participated in a visit to the Yandera site November 7-15, 2014 (Table 2-1), with meetings, field and core inspections taking place November 10-14, 2014 with the other days being dedicated to travel.
- Mike Lelliot, Chartered Geologist (Geological Society of London), Member International Association of Hydrogeologists, BSc Geology, MSc Hydrogeology and Groundwater Quality
- Daniel Moriarty, Principal Environmental & Social Consultant with Coffey, BA Hons (Environmental Studies), BSc
- Travis Wood, Associate Environmental Consultant with Coffey, BSc, First Class Hons (Chemistry).
- Emma Waterhouse, Principal Environmental & Social Consultant with Coffey, BSc, MSc (Hons).
- Anna Yates, Associate Environmental & Social Consultant with Coffey, BSc (Engineering), Master of Public Health (Environmental Health).

**Table 2-1: Qualified Persons Site Visits**

Personnel	Company	Expertise	Date(s) of Visit	Details of Inspection
Jay Pennington	SRK Consulting	Resource Geology	10-14 Nov 2014	Full-time accommodation at the Yandera Camp. Review of core stored at the Camp. Review of data collection method, maps and cross-sections, and digital database. One-day inspection of active drilling at Rima and a field traverse from Rima to Frog Camp.
Tertius le Roux	Advisian	Reserve Evaluation	23 – 28 Jul 2017	QP's Site Visit to the Yandera Project footprint area to gain insight into the pit locations, environmental, social, topographical, logistical and general conditions. Visual inspection of proposed mining and milling precinct and Waste Rock Dump (WRD) locations. On foot excursion to various drill sites, the Gremi pit area and Dengru River.

Source: SRK, 2017



## 2.5 Frequently Used Acronyms, Abbreviations, Definitions and Units of Measure

**Table 2-2: Abbreviations and Definitions**

Abbreviation	Definition
%	Percent
°	Degree (Degrees)
°C	Degrees Centigrade
A	Ampere
A/m <sup>2</sup>	Amperes Per Square Meter
AA	Atomic Absorption
ACE	Allowable Capital Expenditure
Ag	Silver
ANFO	Ammonium Nitrate Fuel Oil
Au	Gold
AuEq	Gold Equivalent Grade
CCD	Counter-Current Decantation
cfm	Cubic Feet Per Minute
CIL	Carbon-In-Leach
CIR	Competent Independent Review
cm	Centimeter
cm <sup>2</sup>	Square Centimeter
cm <sup>3</sup>	Cubic Centimeter
CoG	Cut-Off Grade
ConfC	Confidence Code
CPI	Consumer Price Index
CRec	Core Recovery
CSS	Closed-Side Setting
CTW	Calculated True Width
dia.	Diameter
EIS	Environmental Impact Statement
EMP	Environmental Management Plan
FA	Fire Assay
FoS	Factor of Safety
ft	Foot (Feet)
ft <sup>2</sup>	Square Foot (Feet)
ft <sup>3</sup>	Cubic Foot (Feet)



Abbreviation	Definition
g	Gram
g/l	Gram per Liter
g/t	Grams per tonne
gal	Gallon
g-mol	Gram-Mole
gpm	Gallons Per Minute
ha	Hectares
HDPE	High Density Polyethylene
hp	Horsepower
HTW	Horizontal True Width
ICP	Induced Couple Plasma
ID <sup>2</sup>	Inverse-Distance Squared
ID <sup>3</sup>	Inverse-Distance Cubed
IFC	International Finance Corporation
ILS	Intermediate Leach Solution
IRR	Internal Rate Of Return
kA	Kiloamperes
kg	Kilograms
km	Kilometer
km <sup>2</sup>	Square Kilometer
koz	Thousand Troy Ounce
kt	Thousand Tonnes
kt/d	Thousand Tonnes Per Day
ktpa/y	Thousand Tonnes Per Year Annum
kV	Kilovolt
kW	Kilowatt
kWh	Kilowatt-Hour
kWh/t	Kilowatt-Hour Per Metric Tonne
ℓ	Liter
ℓ /sec	Liters Per Second
ℓ /sec/m	Liters Per Second Per Meter
lb	Pound
LLDDP	Linear Low Density Polyethylene Plastic
LoM	Life of Mine
M	Million
m	Meter



Abbreviation	Definition
M.y.	Million Years
m <sup>2</sup>	Square Meter
m <sup>3</sup>	Cubic Meter
MARN	Ministry Of The Environment And Natural Resources
masl	Meters Above Sea Level
MDA	Mine Development Associates
mg/ℓ	Milligrams/Liter
mm	Millimeter
mm <sup>2</sup>	Square Millimeter
mm <sup>3</sup>	Cubic Millimeter
MME	Mine & Mill Engineering
Moz	Million Troy Ounces
MRMR	Mining Rock Mass Rating
Mt	Million Tonnes
Mtpa	Million Tonnes Per Annum
MTW	Measured True Width
MW	Million Watts
NGO	Non-Governmental Organization
NI 43-101	Canadian National Instrument 43-101
NPV	Net Present Value
OSC	Ontario Securities Commission
oz	Ounce
PLC	Programmable Logic Controller
PLS	Pregnant Leach Solution
PMF	Probable Maximum Flood
ppb	Parts Per Billion
ppm	Parts Per Million
QA/QC	Quality Assurance/Quality Control
RC	Rotary Circulation Drilling
RoM	Run of Mine
RQD	Rock Quality Description
SEC	U.S. Securities & Exchange Commission
sec	Second
SG	Specific Gravity
SPT	Standard Penetration Testing
st	Short Ton (2,000 Pounds)



Abbreviation	Definition
t	Tonne (Metric Ton) (2,204.6 Pounds)
t/d	Tonnes Per Day
t/h	Tonnes Per Hour
tpa	Tonnes Per Annum
TSF	Tailings Storage Facility
TSP	Total Suspended Particulates
UoM	Unit Of Measure
V	Volts
VFD	Variable Frequency Drive
W	Watt
XRD	X-Ray Diffraction
y	Year
µm	Micron

## 2.6 Specific Areas of Responsibility

The following individuals, by virtue of their education, experience and professional association, are considered QP's as defined in the NI 43-101, and are members in good standing of appropriate professional institutions:

- Mr T. le Roux.
- Mr J.B. Pennington.
- Mr M. Dworzanowski.

These QPs are responsible for specific sections (refer to Table 2-3 below).

**Table 2-3: Areas of Responsibility**

Report No & Section(s)		QP Name		
		T. le Roux	J.B. Pennington	M. Dworzanowski
1	Executive Summary	X	X	X
2	Introduction	X	X	X
3	Reliance on Other Experts	X	X	X
4	Property Description and Location		X	
5	Accessibility, Climate, Local Resources, Infrastructure and Physiography	X		
6	History		X	
7	Geological Setting and Mineralization		X	
8	Deposit Types		X	
9	Exploration		X	



Report No & Section(s)		QP Name		
		T. le Roux	J.B. Pennington	M. Dworzanowski
10	Drilling		X	
11	Sample Security, Preparation and Analysis		X	
12	Data Verification		X	
13	Mineral Processing and Metallurgical Testing			X
14	Mineral Resource Estimates		X	
15	Mineral Reserves Estimates	X		
16	Mining Methods	X		
17	Recovery Methods			X
18	Project Infrastructure	X		X
19	Market Studies and Contracts	X		
20	Environmental Studies, Permitting and Social or Community Impact	X		
21	Capital and Operating Costs	X		X
22	Economic Analysis	X		
23	Adjacent Properties		X	
24	Other Relevant Data and Information	X	X	X
25	Interpretation and Conclusions	X	X	X
26	Recommendations	X	X	X
27	References	X	X	X

## 2.7 Effective Dates

There are a number of effective dates for the information included in the Report, as follows:

- Reserve Estimate : 27 November 2017
- Effective Valuation Date : 1 January 2019
- Spot Price : 16 October 2017

Note that the Effective Valuation Date of 1 January 2019 was selected, as this is the anticipated date of the investment decision. It should be noted that all financial model inputs were escalated using CPI, where appropriate, from the study period (2017) to Effective Valuation Date of 1 January 2019.





### 3 Reliance on Other Experts

---

A qualified person who prepares or supervises the preparation of all or part of a technical report may include a limited disclaimer of responsibility if:

- The qualified person is relying on a report, opinion or statement of other subject matter experts, or on information provided by the issuer, concerning legal, political, environmental or tax matters relevant to the technical report, and the qualified person identifies the following:
  - the source of the information relied upon, including the date, title, and author of any report, opinion, or statement;
  - the extent of reliance; and
  - Portions of the technical report to which the disclaimer applies.
- Daniel H. Sepulveda, Associate Consultant (Metallurgy) of SRK Consulting (U.S.), Inc. is the QP responsible for the copper and gold recovery estimate for the oxide mineralization in Section 13.2.5 of this Technical Report
- Cobus Fraser, Director – Valuation and Optimisation of Fraser McGill (Pty) Ltd, is the Qualified Valuator responsible for Sections 19 and 22 of the Yandera Project Pre-feasibility Study Project.

For other experts relied upon, refer to the Authors of Report table above.



## 4 Property Description and Location

### 4.1 Property Location

The Project is located in the southwestern portion of the province of Madang in PNG within the Bismarck Mountain range, at elevations ranging from 1,500 to 2,400m above mean sea level. The project is located at about longitude 145.12°E and latitude 5.75°S, which is about 95km southwest of the city of Madang. The location of the Project relative to other major mineral projects on the island of New Guinea is shown in Figure 4-1.

### 4.2 Mineral Tenure

Era holds two non-contiguous Exploration Licences (EL): EL 1335 (Yandera) and EL 1854 (Lila/Cape Rigny) as listed in Table 4-1 and shown in Figure 4-2. The total tenement package covers 269.4km<sup>2</sup>, but the vast majority of work to date and all the resources on the property have been within EL 1335. EL 1854 is currently under review for renewal.

**Table 4-1: Era Mineral Titles and Status**

Exploration License	Name	Sub-blocks	km <sup>2</sup>	Original Grant Date	Expiry Date	Status
1335	Yandera	72	245.5	20 Nov 2003	19 Nov 2017	Current
1854	Lila/Cape Rigny	7	23.9	29 Jul 2011	27 Jul 2017	Under renewal
<b>TOTAL</b>		<b>79</b>	<b>269.4</b>			



**Figure 4-1: Project Location Map**

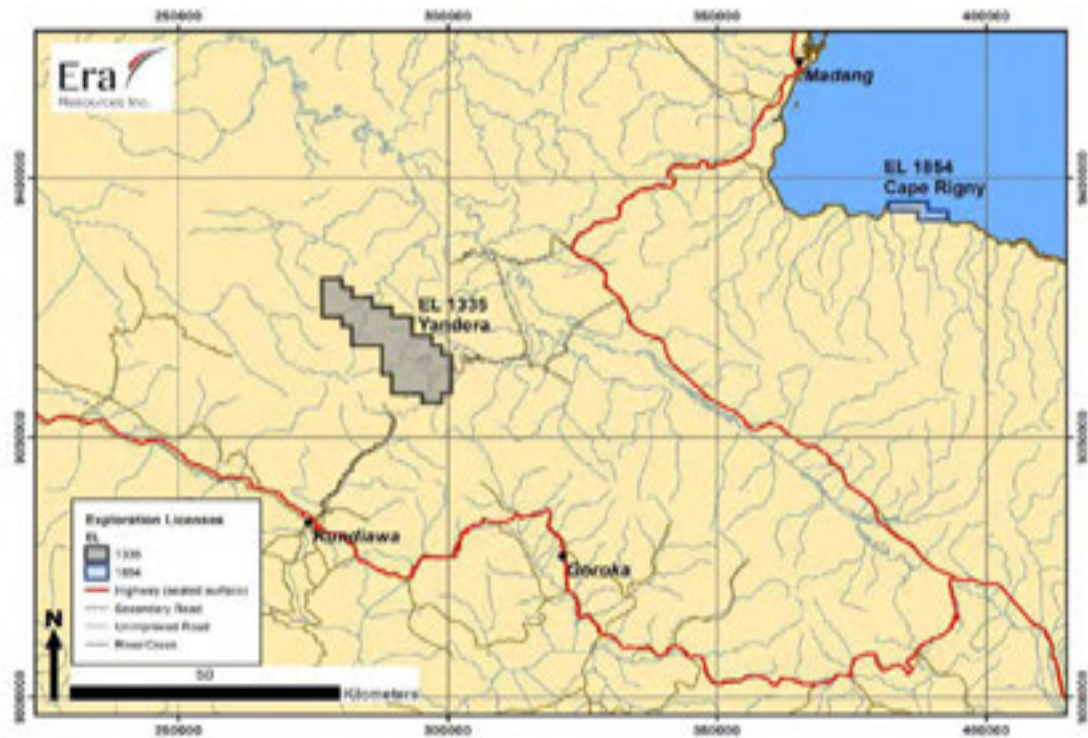


Figure 4-2: Land Tenure Map

### 4.2.1 Nature and Extent of the Issuer’s Interest

In PNG, the national government owns the mineral rights. Individuals and groups are allowed to own the surface rights. The PNG Mining Act of 1992 grants the holder of an EL access to the property for exploration purposes. The Mining Act recognizes compensation for landowners by providing for social disruption compensation.

An EL entitles the holder to exclusively explore for minerals for a period of two years, and gives the holder the right to apply for a mining lease or special mining lease. The mining lease permits the holder to mine the lease exclusively for a period of up to 20 years, with the right to apply for 10-year extensions. The special mining lease permits the holder to mine the lease exclusively for a period of up to 40 years with the right to apply for a renewal of up to 20 years. Once an EL is granted, it must be renewed every two years or at the end of each term. Holders are required to pay rental for each E, and are required to accumulate a minimum amount of expenditures for each EL as shown in the table below. EL 1335 is in its sixth term.

### 4.3 Royalties, Agreement and Encumbrances

As noted above, Era currently holds 100% ownership of the exploration licences. There are no other royalties, back-in rights, or other encumbrances on the property except the Mining Lease royalty to the government of PNG, which is 2% of the net proceeds of sale of minerals and a 0.25% production levy.

In the EL agreements, the state (PNG) reserves the right to purchase up to 30% equity interest in any mineral discovery arising from the EL. The purchase price would include up to a 30% cumulative share of all exploration and development cost to-date.



#### **4.3.1 Environmental Liabilities**

There are no known environmental liabilities for the Project.

#### **4.3.2 Required Permits and Status**

An environment permit is required when undertaking drilling. Era currently holds a permit for drilling and a permit for water extraction. Era was issued these permits under Section 65 of the PNG Environment Act 2000.

If the Project advances into development, other permits and licences would be required.

#### **4.4 Other Factors and Risks**

The Project is located in mountainous terrain, with potential seismic occurrences and relatively high annual rainfall, which provides logistical challenges.



## 5 Accessibility, Climate, Local Resources, Infrastructure and Physiography

### 5.1 Topography, Elevation and Vegetation

#### 5.1.1 Topography and Elevation

The proposed mine area is located in the foothills of the Bismarck Range, which is part of the central cordillera of New Guinea at an elevation of approximately 1,900m above sea level. The site is situated on the northern side of the range, about 13km east-northeast from Mt Wilhelm, with the extensive floodplain of the Ramu River approximately 20km to the east. The mine site area is mountainous with the Imbrum River valley to the west and the Tai-Yor River valley to the east.

The ore slurry pipeline to Cape Rigny, access roads and transmission lines (collectively the Yandera to Cape Rigny Link) will pass through diverse landscapes and topography between the mine and the coast. From the mine area, the elevation decreases towards the Ramu River flood plain over a distance of approximately 20km. Elevations in this area between the mine site and the Ramu River floodplain range from 1,900m to 160m above sea level. The floodplain is about 15km wide with elevations of between 130 and 160m above sea level. From the Ramu River to the coast, elevation increases again at the foothills of the Finisterre Range to over 1,000m above sea level through sections of mountainous terrain. Further east, the elevation decreases along the Rai Coast to typically between 10 and 50m above sea level, where the terrain is largely flat to undulating. Numerous large, braided rivers and smaller watercourses intersect this coastal plain. The coastline generally comprises rocky cliffs and sandy beaches with fringing reefs present along much of the coast.

The facilities at Cape Rigny (at about 10m above sea level) would be located in an area of gentle topography and relatively flat coastal plains. A number of small sand beaches indent the coastline.

#### 5.1.2 Vegetation

Vegetation is generally a mix of gardens and grassland, with some large- to medium-crowned forest remaining. Site visits have confirmed that ridges generally consist of grasslands and gardens containing subsistence crops, while slopes varied between grassland, gardens and forest. The terrestrial ecoregion near the mine site is classified by the World Wildlife Fund (WWF) as the "Central Range Montane Rainforest Ecoregion" (Independent State of Papua New Guinea, 2010). The Forest Inventory and Mapping (FIM) project (Hammermaster and Saunders, 1995) classified the entire mine area as "non vegetation and areas dominated by land-use".

Detailed mapping of the mine area identified both natural forest and vegetation types derived from human activity. These types of vegetation include patches of mixed lower montane forest, secondary/transitional or regrowth forest and Miscanthus grassland (3D Environmental, 2012).

Between the mine area and the coast, the pipelines and road traverse two ecoregions and a range of altitudinal zones and vegetation types. Vegetation and habitat in this area includes lower montane forest, mixed hill forest, mixed alluvium forest, kunai grassland and transition/anthropogenic forest types.



Small villages, gardens and settlements are concentrated on the fringes of the Ramu River with extensive areas of the valley covered in intact swamp and alluvial rainforest.

Cape Rigny is located within the “Huon Peninsula montane rain forests” terrestrial ecoregion (3D Environmental, 2012). Vegetation here is characterized by primary lowland rainforest interspersed with settlements and gardens. Along the coastal fringe, coconut and other forms of subsistence agriculture and cash crop plantations have replaced much of the natural vegetation.

Sixteen plant species of conservation significance were identified as known or potentially occurring in the project area (3D Environmental, 2012). One of these species was classified under the International Union for Conservation of Nature (IUCN) as “Critically Endangered” (*Diospyros lolinopsis*) and was recorded along the Yandera to Cape Rigny Link about 10km northeast of Usino. One IUCN-listed “Endangered” tree species (*Flindersia pimenteliana*) was considered likely to occur along the Yandera to Cape Rigny Link in mixed hill forest. A further seven species listed as “Vulnerable” were identified as likely to occur in the project area.

Lowland forests and river systems near the project area are known habitats for a range of threatened and endemic fauna species and threatened flora species including *Diospyros lolinopsis*. The limited disturbance and canopy proliferation of “Vulnerable” tree species such as *Intsia bijuga* (kwila) and *Pterocarpus indicus* (New Guinea rosewood) also add value to the forests as habitat for fauna species.

Exotic species, including some highly invasive weeds, were recorded in field surveys. Such species are more prevalent in the foothills and lowland habitats. In the mine area, introduced species are common in the landscape and are indicative of the ongoing disturbance regime associated with gardening.

## 5.2 Accessibility and Transportation to the Property

The project is located approximately 95km to the southwest from the coastal city of Madang (population approximately 30,000), which is the capital city of Madang Province. The project is also approximately 235km to the northwest of Lae (population of about 100,000), which is known as the largest port city in PNG and an important industrial centre. Both cities have active port facilities with tidewater access, and there is a maintained road between them.

There are several other population centres near the property. The two largest are Mt Hagen (population of about 46,000), which is about 100km to the southwest of the property, and Goroka, (population of about 20,000), which is about 47km to the southeast of the property.

Within EL 1335, the largest population centre is the village of Yandera (population approximately 4,000), which lies about 2km east of the footprint of the Mineral Resource. Much of the remaining population in the project area live in dwellings dispersed along walking trails.

Era currently uses Madang as its logistical base of operations. Materials and labour are transported from Madang to the project site via helicopter, with a departure point of Madang airport or, more commonly, from a lay-down yard (“Lay Down 5”) that is accessible via a road that travels through the village of Usino.

The Ramu River is a prominent northwest trending river that drains to the northwest, and eventually reaches the ocean near the northwest corner of Madang Province. Lay Down 5 and Usino are both on the northeast side of the Ramu River.





Era has almost exclusively accessed the property via helicopter as there are no conveniently located landing strips with capacity for reasonable sized fixed-wing aircraft. The closest existing road that could access the property is located to the east of EL 1335, near the village of Bundi. Locals from Yandera Village use an existing trail that passes through Snowpass to reach Bundi. Some locals also use trails to travel southward through Pandambai Junction to reach Goroka or the smaller road-accessible village of Kundiawa. The existing trails and road are mainly used for walking and are not in a condition suitable for bringing in personnel or materials.

The unimproved highlands trail to the south end of EL 1335 and the Yandera Camp are shown in Figure 5-1 below.

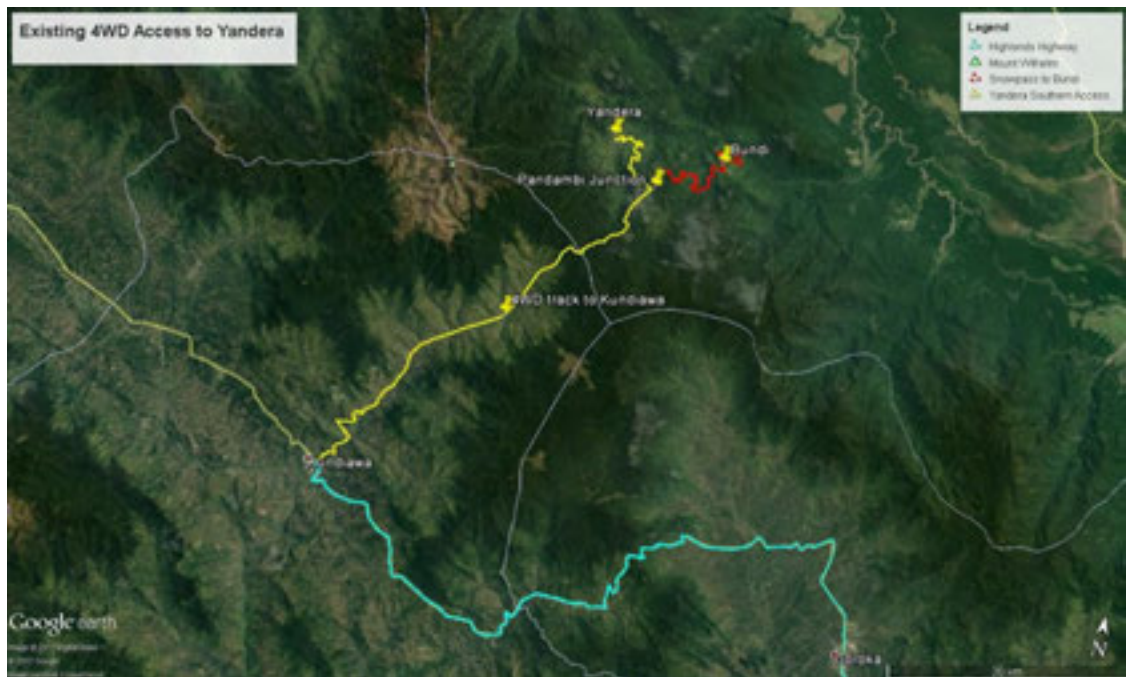


Figure 5-1: Site Access Map

## 5.3 Climate and Length of Operating Season

The climate of the region is dominated by two main seasons. The northwest monsoon (wet) season occurs annually between December and March, and the southeast monsoon (dry) season occurs annually between June and September (SLR, 2012). High, localised rainfall events can still occur in the dry season. Yandera operations will be year-round throughout the wet and dry seasons.

### 5.3.1 Yandera Area

Historic climate information is available from a weather station installed at Yandera in late April 2007, which collected data until 2012. A complete annual record of rainfall and evaporation data is available for the Yandera weather station in 2008, when annual rainfall and evaporation were 5,038mm and 1,296mm respectively. Records from this station also indicate that:

- Wind speeds average approximately 1m/s, with maximum daily peak wind gusts of around 4 to 5m/s.
- Wind directions are generally from the northeast during the day and southwest during the night.



- No seasonal temperature variation is apparent. Mean temperatures are around 18°C with a mean daily maximum of approximately 25°C and mean daily minimum of around 15°C.
- Humidity averages 89% during the day and generally falls to 60 to 70% at night.
- Annual rainfall is around 5m, with most rain falling between November and March.
- Rainfall greatly exceeds evaporation.

The Yandera area typically experiences more than 400mm rainfall per month on average. In contrast, on the coast, rainfall is typically in the order of 275mm per month on average.

Era installed a new weather station at Yandera in April 2017. Weather monitoring from 22 April to 27 July 2017 showed that:

- Maximum daily temperatures range between 20 and 25°C.
- Minimum daily temperatures were around 15°C.
- Daily rainfall ranged between 0 and 30mm.
- Total rainfall recorded from April to July was approximately 700mm (as recorded by two rain gauges).
- Average relative humidity ranged between approximately 75 and 90%.
- Average barometric pressure was relatively constant at around 840hPa.
- Daily evaporation ranged between 0 and 1.5mm.
- Maximum wind speeds were between 10 and 35km/hr.
- Average wind speeds were generally below 5km/hr.
- Average solar radiation was between 10 and 35 watts per square meter (W/m<sup>2</sup>).

### 5.3.2 Yandera to Cape Rigny Link

Monthly total rainfall data were recorded at a National Weather Service weather station at Bundi over the period from 1958 to 1991. No other parameters were measured at the site. This station is located approximately 10km southeast of the Yandera to Cape Rigny Link and 10km east of the Yandera site. The rainfall recorded at Bundi is assumed representative of rainfall typical of the route of the Yandera to Cape Rigny Link, except for the coastal area.

The wettest recorded year at Bundi was 1966, with a total annual rainfall of 5,834mm, and the driest year (for which full data were available) was 1974, when 3,721mm of rain fell. The average annual rainfall over the 34-year data recording period was 4,456mm, with the driest months being May to September and the wettest being December to April. This pattern of rainfall is broadly consistent with the May to October dry season and November to April wet season experienced more widely in PNG and is comparable to rainfall data recorded at the Yandera weather station from 2007 to 2012.

### 5.3.3 Cape Rigny

Historic rainfall and wind data for the coastal area are available from a National Weather Service weather station located at Madang Airport, approximately 25km to the northwest of Cape Rigny. Monthly total rainfall and wind direction data are available from 1977 to 1997. The climate at this site is likely to be similar to that at Cape Rigny.





Average annual rainfall at Madang Airport from 1977 to 1997 was 3,288mm, with the driest months being June to October and the wettest being December to April. This region of PNG has a hot and humid tropical climate with relatively consistent year-round temperatures.

Wind data recorded at Madang between 1977 and 1997 show that the dominant wind directions over the monitoring period were northeasterlies and easterlies. This wind pattern indicates the presence of a local land and sea breeze circulation system at Madang, which overrides the large-scale wind flow system of northwesterlies that typically occurs over PNG from January to April, and southeasterlies from July to October (McAlpine et al., 1983). Era installed a weather station at Lila, Cape Rigny in April 2017. Data from this weather station recorded from 27 April to 15 July 2017 showed:

- Maximum daily temperatures between 30 to 35°C and minimum between 20 to 25°C.
- Relative humidity between 85% and 97%.
- Maximum recorded daily rainfall of approximately 18mm (total rainfall of 111mm from April to July).
- Barometric pressure ranged between 1007 and 1011 hPa.
- Daily evaporation largely ranged between 2 to 4mm, with a maximum of 6mm recorded.
- Average wind speed was approximately 0 to 1km/hr, with maximum wind speed between approximately 10 and 25km/hr.
- Average solar radiation was approximately 100 to 250 W/m<sup>2</sup>.

All three areas of the Yandera Project (Mine area, Yandera to Cape Rigny Link and Cape Rigny) receive in the order of 3 to 5m of rainfall per year. This very high rainfall means that excess water needs to be managed in the pit and the waste rock dump facility at the mine site. Measures also need to be implemented to maintain land stability, and to prevent erosion along the link and exposure to/runoff from concentrate stockpiles at the port site facilities in Cape Rigny.

Tropical cyclones affect the southern areas of PNG between November and April but have not been recorded as far north as Madang or Cape Rigny (World Bank, 2008). Climate change has already resulted in increased annual maximum and minimum temperatures since 1950 (as recorded in Port Moresby), and the sea level has risen near PNG by about 7mm per year since 1993, which is higher than the global average of 2.8 to 3.6mm per year (Pacific Climate Change Science Program, 2011). The trend of rising temperatures and sea levels is expected to continue, and the total number of annual cyclones is expected to decrease, with the frequency of more intense storms expected to increase (Pacific Climate Change Science Program, 2011).

The Yandera area frequently experiences fog conditions, particularly in the morning. This is common for high rainfall environments in elevated terrain in PNG. It is expected that the coastal area would experience little fog year-round. Based on precedence from other similar projects in PNG, the effects of fog on project productivity are expected to be low (i.e. resulting in the order of less than 1% production loss).

## 5.4 Sufficiency of Surface Rights

Currently, the surface rights for the Project are sufficient to continue exploration work. When the Project moves to apply for a special mining lease, additional arrangements and agreements with current landowners will be required through an LOA.



## 5.5 Infrastructure Availability and Sources

### 5.5.1 Infrastructure Available

Currently the Project is helicopter-supported in virtually all aspects. Fuel, materials, equipment and personnel are flown to camp directly from Madang or from “lay-down” locations accessible by the roads connecting Madang and Lae. These lay-down locations are typically a 10 to 12 minute helicopter flight one-way.

Heli Niugini in the form of a Bell 407 has provided much of the recent helicopter support. There are some government maintained roads to the east of EL 1335, but at present, these roads have not been improved or extended sufficiently such that materials can be brought into any of the camps on a safe and regular basis.

Locals near the Project sell fresh fruit and vegetables to the camp but other staples such as rice and meats have to be flown in. Power for the camp facilities is provided with diesel-powered generators. There are no overhead telephone lines; however, there is a Digicel tower that provides mobile phone access for a large portion of the project area.

### 5.5.2 Water Source

Water is required at the Yandera site for operations (e.g. milling, slurring of ore, dust suppression, WRD construction, concrete mixing, potable water supply as well as haul road construction and maintenance. Details of the water inputs and outputs are detailed in Sections 17 and 18. A preliminary water balance for the Yandera site is presented in the Yandera Project Pre-Feasibility Study, Water Balance (Advisian, 2017b).

The water balance indicates the project water demand can be met from the surface catchments surrounding the main mining infrastructure for a normal range of climatic conditions. This water comprises rainfall runoff plus groundwater draining into the open pits. Under drought conditions (assessed as four contiguous months of low rainfall) there may be a shortfall for two months during the dry season, which can be mitigated through appropriate water storage (e.g., upstream of the WRD) or an alternative external water source (e.g., Imbrum River).

The primary source of water available in the project area is rainfall runoff. Groundwater is also a potential source of water, although the hydraulic properties of the bedrock in the area mean that the quantities available are expected to be relatively small.

Water supply potential to meet general mine operating conditions has been appraised under average, high, low, and drought annual rainfall conditions. The water balance indicates the project water demand can be met from the surface catchments surrounding the main mining infrastructure for a normal range of climatic conditions.



The Dengru Creek catchment is anticipated to be the most impacted due to the concentration of mining activities in this area. For this reason, it is best for the water from this catchment to be used for make-up supply. Under most climatic conditions, the make-up demand is greater than this supply; hence, all of the water will be used. However, under high rainfall conditions, some of the water will be excess to requirement and will require discharge to the environment following appropriate treatment to meet discharge standards.

Potable water for the mine camp will be sourced from the Mogoru Creek upstream of the WRD<sup>1</sup>. The Mogoru Creek may additionally be used to provide potable water to Yandera Village if the settlement is not relocated.

---

<sup>1</sup> The WRD design has changed since the water balance report was produced, with waste material to now also be deposited in the Mogoru Creek catchment. The effect of this is to reduce the available contributing catchment and unaffected water flows for the Mogoru Creek upstream of the WRD. However, potable demands are low and the reduced catchment area is still considered sufficient to meet demand.



## 6 History

### 6.1 Prior Ownership and Ownership Changes

In 1965, Kennecott acquired the EL to work on the property. It continued ownership and operated until 1973, when Triako Mines acquired the property and had its operator, Amdex, complete its work programmes. Amdex jointly worked with Broken Hill Proprietary Company (BHP) on the property from 1974 to 1977. In 1978, Amdex entered into a joint venture with Buka Minerals. Work and joint ownership continued until 1984, when the two companies dropped the property.

The property sat idle until 1999, when Highland Pacific and Cyprus Amax acquired an EL and worked on the property, dropping it before 2000. The property then sat idle until Belvedere Limited acquired the EL for the property. In 2005, Belvedere formed a joint venture with Marengo, who operated the property. In 2006, Marengo acquired 100% ownership of the property through purchase of Belvedere's interest. Marengo has subsequently changed its name to Era, and is the sole owner of the property.

### 6.2 Exploration and Development Results of Previous Owners

Geologists from the Australian Bureau of Mineral Resources first investigated outcrops of copper mineralization near Yandera village in the mid-1950s and early 1960s. Kennecott Exploration ran the first systematic exploration of the project area from 1965 to 1972. Over the course of its work, it completed geochemical sampling of stream sediment, soil, and rock; completed detailed geological mapping; completed several ground-based magnetic and induced polarization surveys; and completed 14 diamond drillholes that total 2,276m drilled length.

From 1973 to 1977, Broken Hill Proprietary Company Limited (BHP) and Amdex Mining Limited jointly completed 82 diamond drillholes that total about 27,620m drilled length. This joint venture completed additional geochemical sampling, mapping, and contour trenching programmes. The results of this were the identification of the Imbruminda, Gremi, and Omora prospect areas. After BHP left the venture, Amdex continued to drill 10 holes, which totalled 3,323m of drilled length, and explore with surface mapping, sampling and some ground geophysics until they dropped the property in 1984.

In 1999, Highlands Pacific/Cyprus Amax completed surface mapping, sampling and trenching.

### 6.3 Historical Mineral Resources and Reserve Estimates

This section is excerpted from Ravensgate, 2012:

Several resource estimates were completed for the Project in the 1970s. However, these pre-date all versions of modern reporting codes. In 2007, an indicated resource of 163Mt at 0.49% Cu equivalent and inferred resource of 497Mt at 0.48% Cu equivalent was estimated by Golder Associates (Golder) in accordance with JORC (2004).

Golder completed a resource estimate at Yandera prepared in accordance with JORC (2004) guidelines in August 2008. This resource was based on 175 diamond drillholes (57,000m) including drilling completed by Era from 2006 to 2008. The interpolation method used by Golder was by ordinary kriging and included estimations for Cu, Mo and Au. Rhenium was also estimated using a linear regression based on Mo grades.



In 2011, Golder completed a JORC (2004) compliant resource based on 345 diamond drillholes (113,715m), which included drilling from 2006 to January 2011. Golder used an OK interpolation method, which included separate estimations for Cu, Mo, Au, and Ag (rhenium (Re) was estimated from a linear regression based on Mo grades). In this resource, all Au, Ag and Re resources were inferred. The mineral resource form Cu and Mo as stated in Golder, 2011 is presented in Table 6-1.

**Table 6-1: Yandera Mineral Resource Statement by Golder 2011 at 0.2% Copper Equivalent Cut-off Grade**

Resource Category 0.20 CuEq% Cut-off	Mass Mt	Grade			Contained Metal	
		CuEq%	Cu ppm	Mo ppm	Cu (kt)	Mo (kt)
Measured	132	0.53	3,700	167	488	22
Indicated	490	0.35	2,772	89	1,358	44
<b>Combined, Measured &amp; Indicated</b>	<b>622</b>	<b>0.39</b>	<b>2,968</b>	<b>108</b>	<b>1,846</b>	<b>67</b>
Inferred	1,017	0,33	2,840	68	2,888	69

Source: Golder 2011

A sensitivity analysis of resources over a range of Cut-Off Grades (CoGs) is presented in Golder, 2011 and is not reiterated here.

In 2012, Ravensgate completed a JORC-compliant resource based on 462 diamond drillholes (145,258m), which included additional drilling from February 2011 to February 2012. Ravensgate used an OK interpolation method, which included separate estimations for Cu, Mo, and Au. The mineral resource form Cu, Mo and Au as stated by Ravensgate in 2012 is presented in Table 6-2. Note this statement uses a copper CoG.

**Table 6-2: Yandera Mineral Resource Estimate by Ravensgate 2012 at 0.2% Copper Cut-off Grade**

Resource Category 0.20 CuEq% Cut-off	Mass Mt	Grade			Contained Metal		
		Cu %	Mo ppm	Au ppm	Cu (kt)	Mo (kt)	Au (t)
Measured	314	0.38	104.6	0.085	1,193	33	27
Indicated	172	0.35	52.7	0.048	602	9	8
<b>Combined, Measured &amp; Indicated</b>	<b>486</b>	<b>0.37</b>	<b>105.2</b>	<b>0.09</b>	<b>1,798</b>	<b>51</b>	<b>44</b>
Inferred	347	0.31	37.8	0.03	1,076	13	10

Source: Ravensgate, 2012

A sensitivity analysis of resources over a range of CoGs is presented in Ravensgate, 2012 and not reiterated here.

In 2015, SRK completed a NI 43-101 and JORC-compliant resource based on 553 diamond drillholes (32,250 samples), which included drilling from March 2012 to December 2014. SRK used an OK interpolation method, which included separate estimations for Cu, Mo, and Au. The mineral resource form Cu, Mo and Au as stated by SRK in 2015 is presented in Table 6-3. Note this statement uses a Copper Equivalent (CuEq) CoG.



**Table 6-3: Yandera Mineral Resource Statement by SRK 2015 at 0.15% Copper Equivalent Cut-off Grade**

Resource Category 0.15 CuEq% Cut-off	Mass Mt	Grade				Contained Metal			
		CuEq%	Cu %	Mo %	Au ppm	Cu (kt)	Mo (kt)	Au (koz)	CuEq (kt)
Measured	195	0.46	0.37	0.013	0.076	723	25	476	890
Indicated	435	0.38	0.32	0.008	0.069	1,379	37	963	1,663
<b>Combined, Measured &amp; Indicated</b>	<b>630</b>	<b>0.41</b>	<b>0.33</b>	<b>0.010</b>	<b>0.071</b>	<b>2,103</b>	<b>62</b>	<b>1,439</b>	<b>2,664</b>
Inferred	117	0.34	0.30	0.005	0.052	348	6	195	401

Source: SRK, 2015

In 2017 (SRK, 2017), SRK completed an NI 43-101 and JORC-compliant resource based on 568 diamond drillholes (58,212 samples), which included drilling of 43 new diamond drillholes in 2016. SRK used an OK interpolation method, which included separate estimations for Cu, Mo and Au. The drilling in 2016 focused on filling gaps between existing known mineralized areas and extending Dimbi and Benbenubu mineralization to the southeast. The most significant improvement to the modelling data set was the addition of cross-section geology of the full deposit prepared by Era and modelled by SRK. The mineral resource form Cu, Mo, and Au as stated in SRK, 2017 is the mineral resource being used as the basis for this PFS.

## 6.4 Production from the Property

There has been no known historic production at the property.

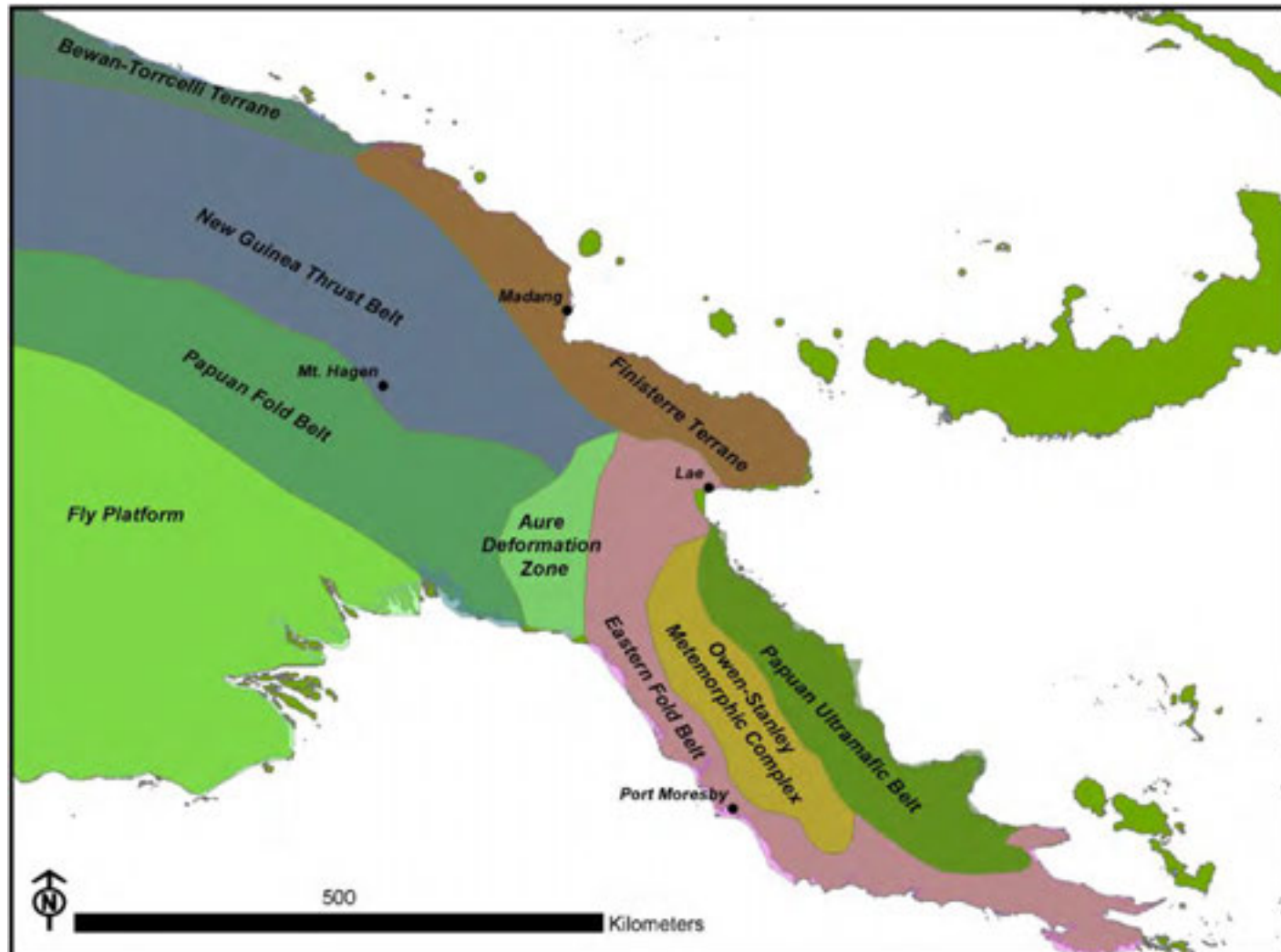


## 7 Geological Setting and Mineralization

### 7.1 Regional Geology

The island of New Guinea is a zone of complex interaction between the Indo-Australian and Pacific plates. The result is a number of microplates accommodating the large-scale compression and transpression by rotation, subduction, dip-slip and strike slip movement, and localized temporal extension. The resultant New Guinea Mobile Belt (regionally divided into packages of fold and thrust belts) encompasses the mountainous region running centrally through the length of the island, and includes slices of metamorphic basement, ophiolites and a myriad of intrusive and sedimentary packages. A simplified illustration of the major litho-tectonic terranes of New Guinea is shown in Figure 7-1 (after Dow, 1977).

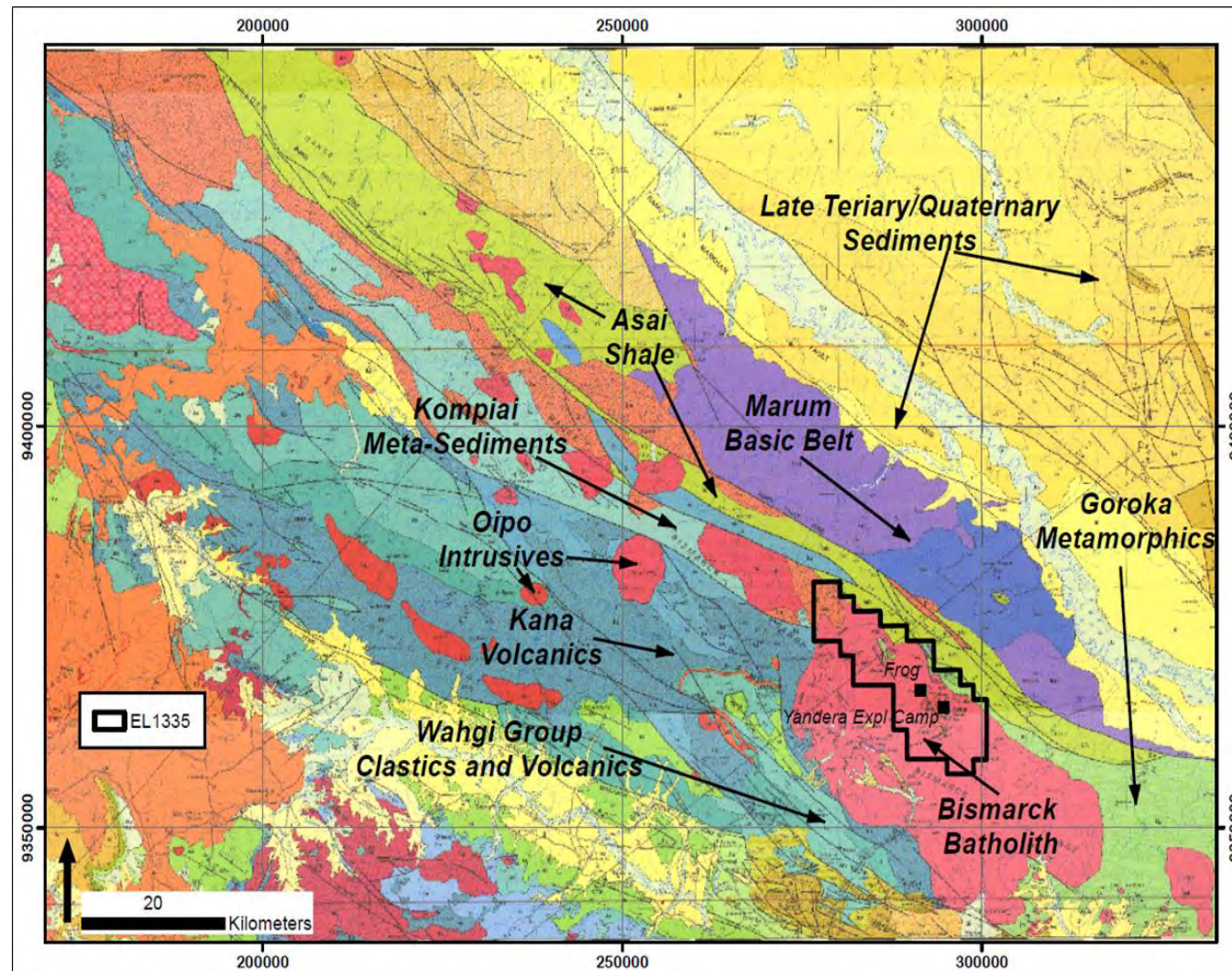
The property lies within the New Guinea Mobile Belt, which stretches from the southeastern portion of the island through the central mountain ranges into Indonesia, and to the west of Freeport's Grasberg Cu-Au deposit. On top of metamorphosed late Paleozoic and early Mesozoic schists, marbles and granodiorite lie successive packages of Triassic to Jurassic volcanic, volcanogenic, and clastic sediments, and Jurassic to Cretaceous clastic, volcanic, and volcanogenic sediments. Early Tertiary (Eocene to Miocene) carbonates and clastic sediments overly the Mesozoic sediments. Middle Tertiary (Miocene) granodiorites and diorites, such as the Bismarck Intrusive Complex, intrude older sedimentary and metamorphic packages along a strong northwest structural fabric (e.g., Ramu Fault), which generated low-grade metamorphic conditions in some of the late Mesozoic sediments (e.g., Asai shale) and emplaced the Miocene Marum Basic Belt. Late Tertiary (Pliocene) clastic-dominated sediments rest on some of these hypabyssal units. Pleistocene clastic units with local Quaternary volcanic and localized alluvium cap the stratigraphy. Regional geology is shown in Figure 7-2 (after Bain and Mackenzie, 1975).



Source: Era, 2015

Figure 7-1: Geologic Terranes of New Guinea





Source: SRK, 2015

**Figure 7-2: Regional Geology Map**



## 7.2 Local Setting

The bulk of the property and the current resource lie within the Bismarck intrusive complex. In this portion of the complex, porphyritic quartz diorite phases (POD on Figure 7-3) intrude the 12 to 14 Ma (Grant and Neilson, 1978; and Page, 1976) host granodiorite (HGR), which comprises the bulk of the Bismarck Intrusive Complex. At the northeast boundary of the Bismarck Intrusive Complex is a package of moderately metamorphosed late Paleozoic and early Triassic sediments whose contact with the Bismarck Intrusive Complex strikes northeasterly, parallel to a very strong regional trend, i.e. the Ramu Fault Zone. This northwest trending structural zone juxtaposed the Miocene Ramu Ophiolite Complex (within the Marum Basic Belt), which hosts the Ramu Nickel deposit, against the late Mesozoic sediments that delineate the northeast boundary of the Bismarck Intrusive Complex. Local geology is shown in Figure 7-3 (after Timm, 2012).

The geometry of the Bismarck intrusive complex and fold and thrust belts reflects large-scale orientation of northeast-southwest directed subduction. Changes in the regional stress resulted in a shift to dominantly strike-slip movement along features like the Ramu Fault Zone. Younger intrusive bodies, faults and mineralized veins observed at Yandera suggest locally there was a period of north-south directed compression followed by a period of northeast-southwest directed compression (or northwest-southeast extension), before the onset of some of broader regional tectonic relaxation.

## 7.3 Property Geology

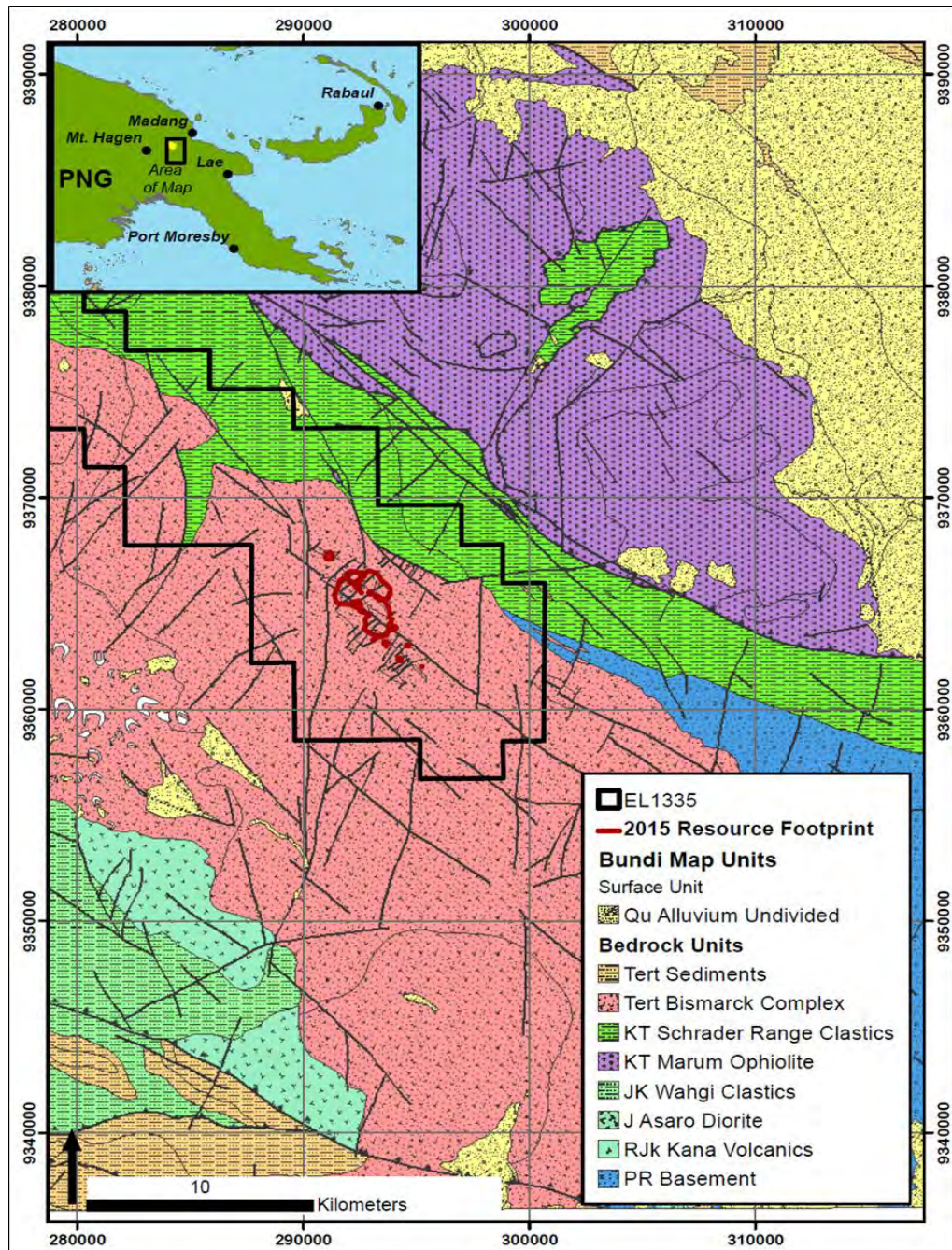
A number of younger igneous units, including a later porphyritic quartz diorite (POK), porphyritic dacite (PDA), andesite (PAN), microdiorite (POM), and some leucocratic quartz diorite (PLQ), intrude the volumetrically larger quartz diorite porphyry (POD) phases at the property. The younger igneous phases are generally tabular in geometry, sub-vertical, and likely reflect structural zones that were important at the time of emplacement of each. A map of the property geology is provided in Figure 7-4.

Within and around the large bodies of POD there are domains of porphyry-style alteration. Within a broad envelope of propylitic alteration, there are more limited domains of potassic alteration and phyllic alteration. Domains of phyllic alteration commonly envelope structures as well as some of the younger intrusive units within domains of potassic and even propylitic alteration. A map of the property alteration is provided in Figure 7-5.

In association with some of these intrusive units, particularly the porphyritic dacite, there are localized hydrothermal or intrusive breccias. These breccias are commonly closely associated with zones of phyllic alteration. Tectonic breccias observed at the property commonly appear very planar, and sometimes have envelopes of phyllic alteration.

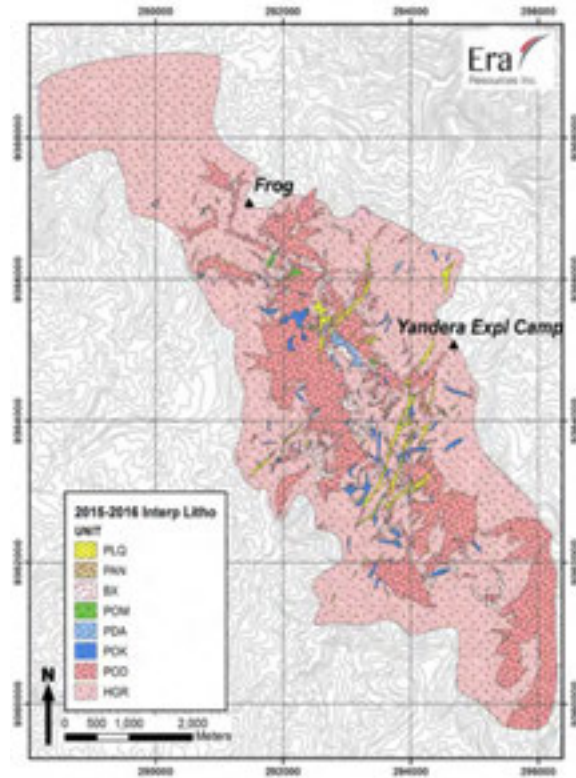
While there is a prominent northwest striking structural trend (300°), there are several other important structural trends including a prominent north-north-westerly trend (330° to 360°) and a north-easterly trend (030°). The northwest trend appears to be the oldest of the three, and reflects the regional-scale structural grain. The north-north-westerly trend cuts the northwesterly trend in a number of locations, but there are some instances when the northwest trend offsets the north-north-westerly trend. The northeast trend appears to be one of the youngest trends, and a number of veins and fractures throughout the property, as well as some prominent sub-vertical dikes of PLQ reflect it.





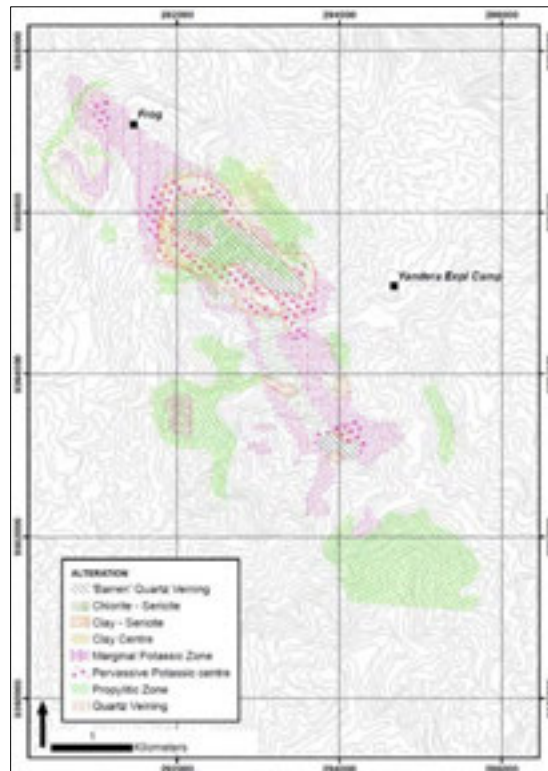
Source: SRK, 2015

**Figure 7-3: Local Geology Map**



Source: Era, 2016

**Figure 7-4: Property Geology Map**



Source: SRK, 2015

**Figure 7-5: Property Alteration Map**





Work on some of the smaller intrusive bodies indicates that they may be as young as 7.1 to 6.3 Ma (Roberts, 2012) may, which suggests that mineralization may be younger than previous investigations appreciated (Tittley et al. 1978; and Watmuff, 1978).

## 7.4 Significant Mineralized Zones

As noted above, this property displays alteration styles in hypabyssal and porphyritic rocks typically observed in porphyry copper systems. Previous work has identified a number of prospects within and around these altered domains including mineralized zones at Gremi, Omora, Imbruminda, Dimbi, Gamagu, Frog and Rima. A number of these areas have distinct styles of copper mineralization but do not appear to fit into the classic porphyry model. These main mineralized zones, overlain on property geology, are shown in Figure 7-5.

Early in the copper mineralization history, there likely were some more typical porphyry-style mineralization events with better mineralization associated with potassically altered cores. However, younger, structurally controlled mineralizing events cut these older systems with phyllic alteration that enhanced zones of copper mineralization locally.

Previous work has been guided with a typical porphyry copper model, including the presence of an interpreted northwesterly elongated “barren quartz core” located between Imbruminda/Gremi and Dimbi. Recent work has led geologists to re-interpret this zone as a structurally bounded block with elevated density of quartz veining with some silicification and evidence of weak to moderate copper mineralization. Work to date on this block is very sparse, and additional work in this zone may show that the bounding structures brought in excess silica remobilized copper mineralization proximal to these structures.

Mineralization is most commonly hosted in breccias, porphyritic dacite, porphyritic microdiorite, quartz diorite porphyry and, less commonly, the granodiorite host. Recent interpretive geologic work suggests that higher-grade copper mineralization is commonly associated with phyllic alteration in association with breccias likely related to emplacement of porphyritic dacite.

The most common sulphide minerals in mineralized domains are pyrite, chalcopyrite, bornite and molybdenite, with varying abundances between prospect areas. For example, bornite is more prominent in the Imbruminda area while chalcopyrite is by far the dominant copper mineral at Omora. Previous investigations have interpreted these changes as evidence of typical zonation in a porphyry system; however, some of these differences may alternatively be explained as structural blocks that have been up-thrown or down-thrown to expose different portions of the mineralized system.

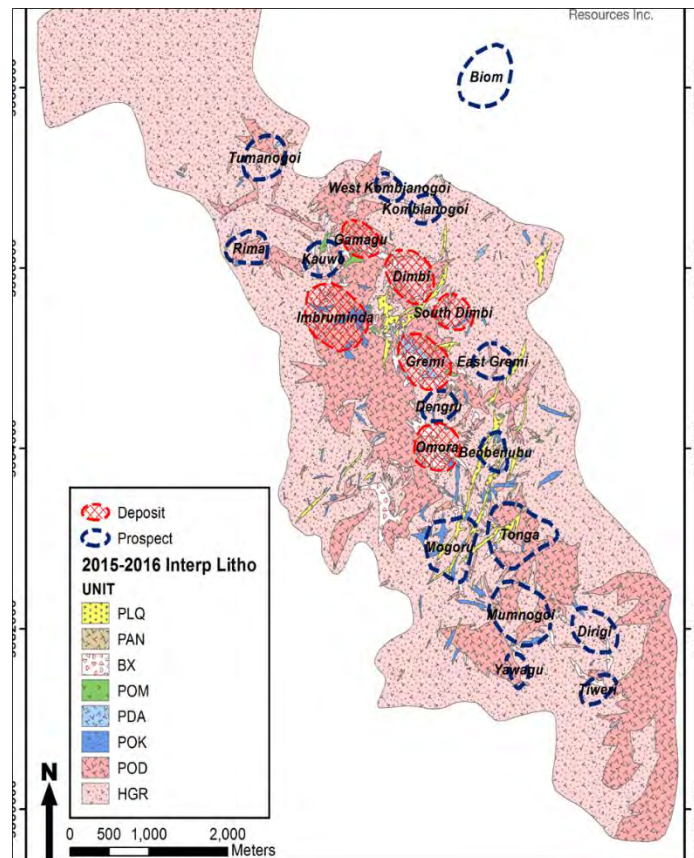
Recent work suggests that large-scale structure is very important to controls for mineralization. Mineralization at Gremi and Dimbi roughly follow a northwest trend; however, higher-grade copper mineralization at Imbruminda is coincident with the intersection of a mineralized north-north-westerly trend and a mineralized northwesterly trend.

Analysis of structural data from oriented core indicates that the largest population of veins, dominantly mineralized in the resource area strike northeasterly and dip steeply (~70°+) to the south-east or north-west. The orientation of these veins is sub-parallel to the most populous drill azimuth in the property. Locally, such as at Rima, mineralized veins and veinlets strike nearly north north westerly and dip steeply (77°+) to the west.



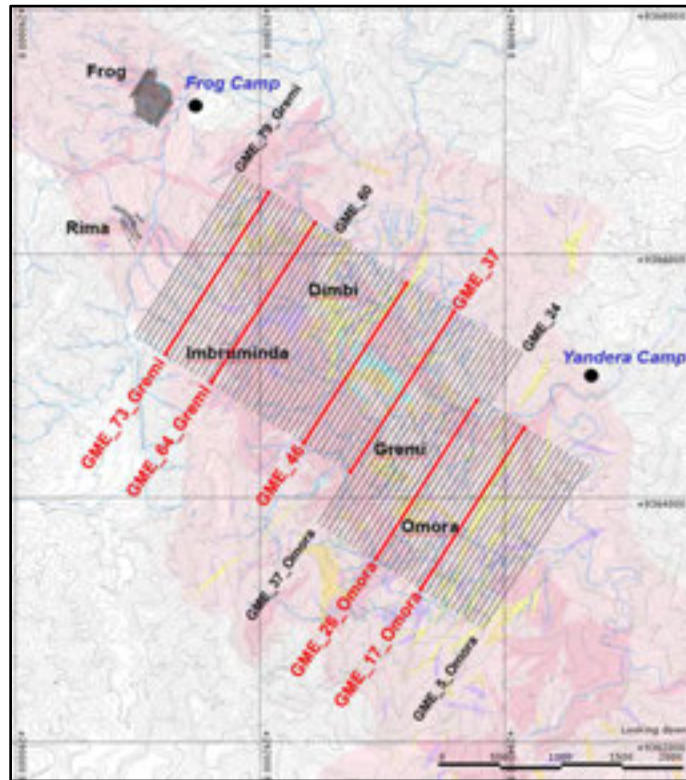
Most of the known copper mineralization is hypogene, and near-surface sulphides have been oxidized to varying depths and degrees. For example, oxide mineralization at Gremi reaches depths of up to 50m, while oxide mineralization at Dimbi is significantly shallower. To date, no significant supergene enrichment blanket has been identified at the property.

Property geology is depicted in a set of cross sections, preceded by a cross section index shown in Figure 7-6. The geologic cross sections are presented in Figure 7-7 to Figure 7-13.



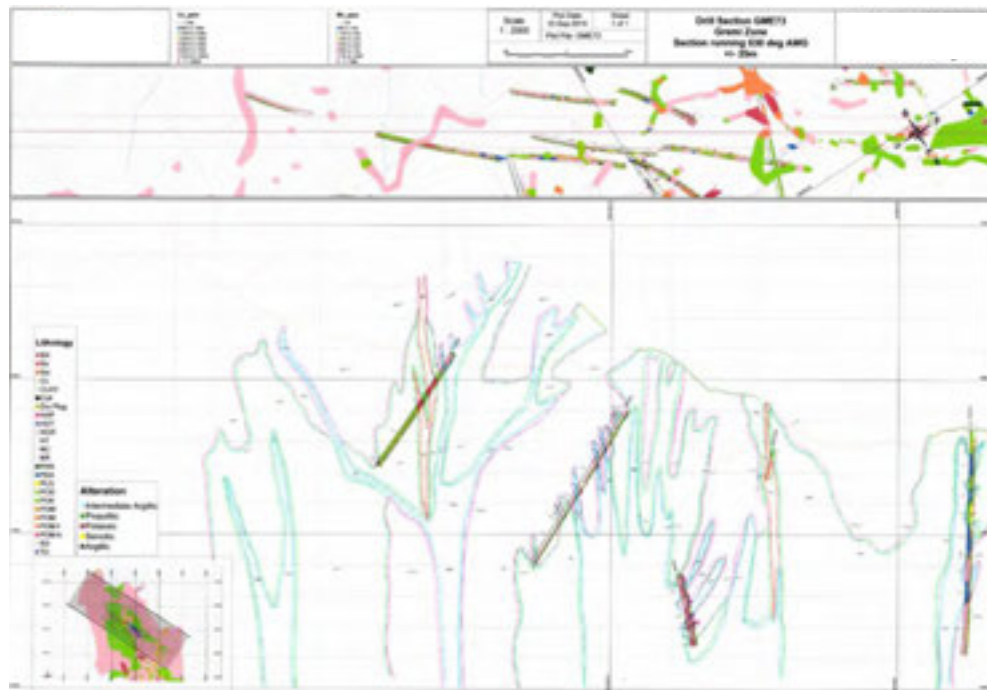
Source: Era, 2016

**Figure 7-6: Main Mineralized Zones**



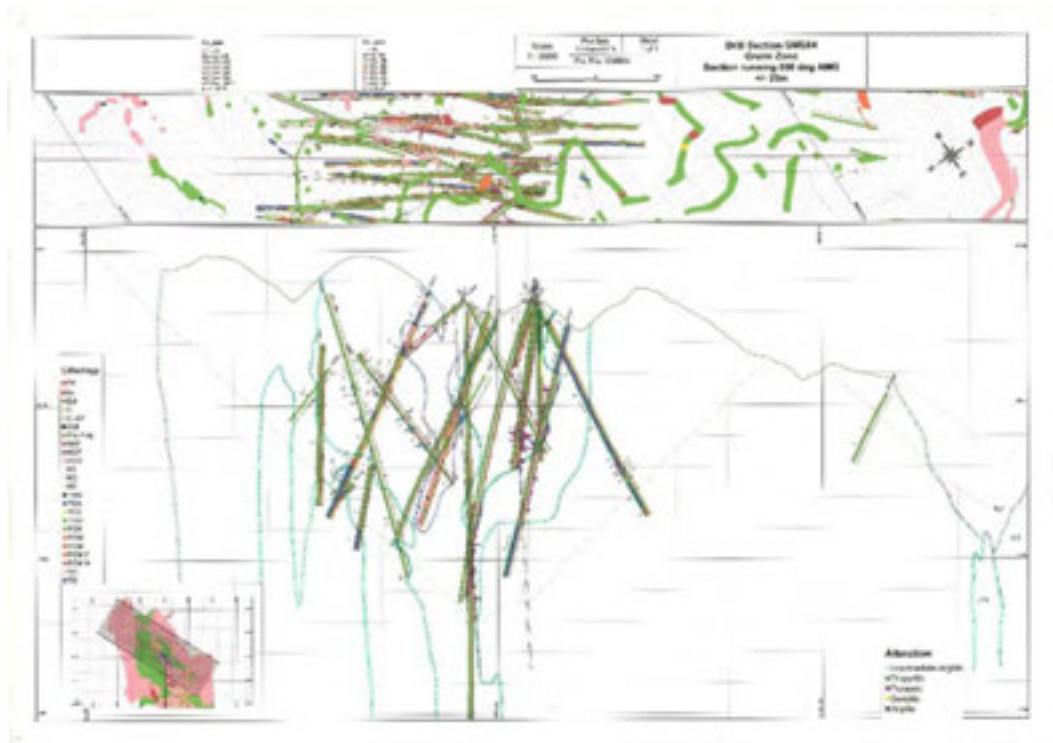
Source: SRK, 2016

**Figure 7-7: Property Geology and Cross Section Index Map**



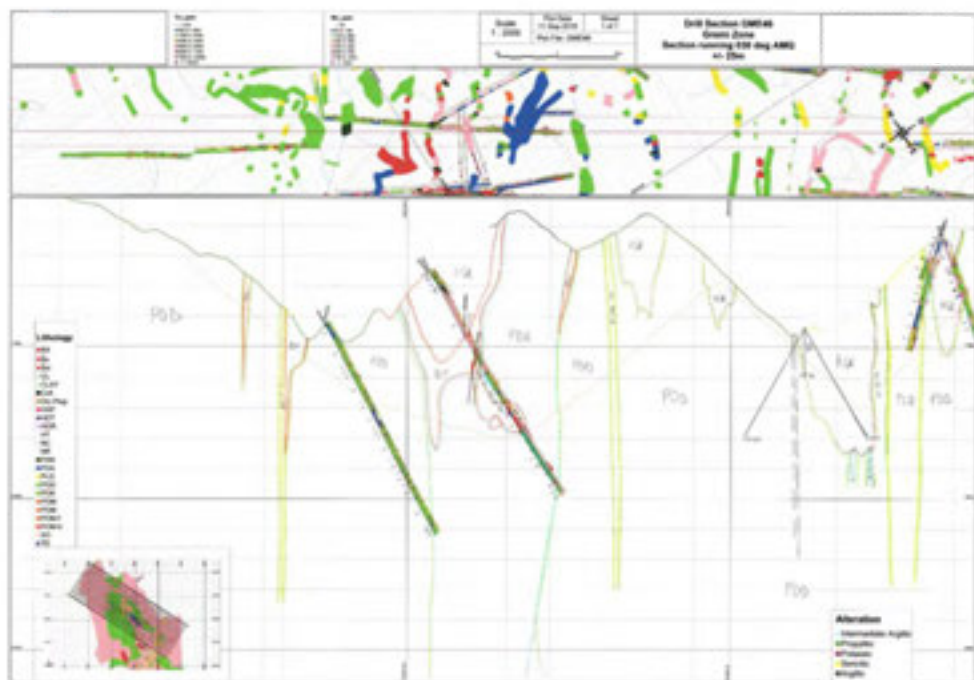
Source: Era, 2016

**Figure 7-8: Geologic Cross Section GME\_73\_Gremi**



Source: Era, 2016

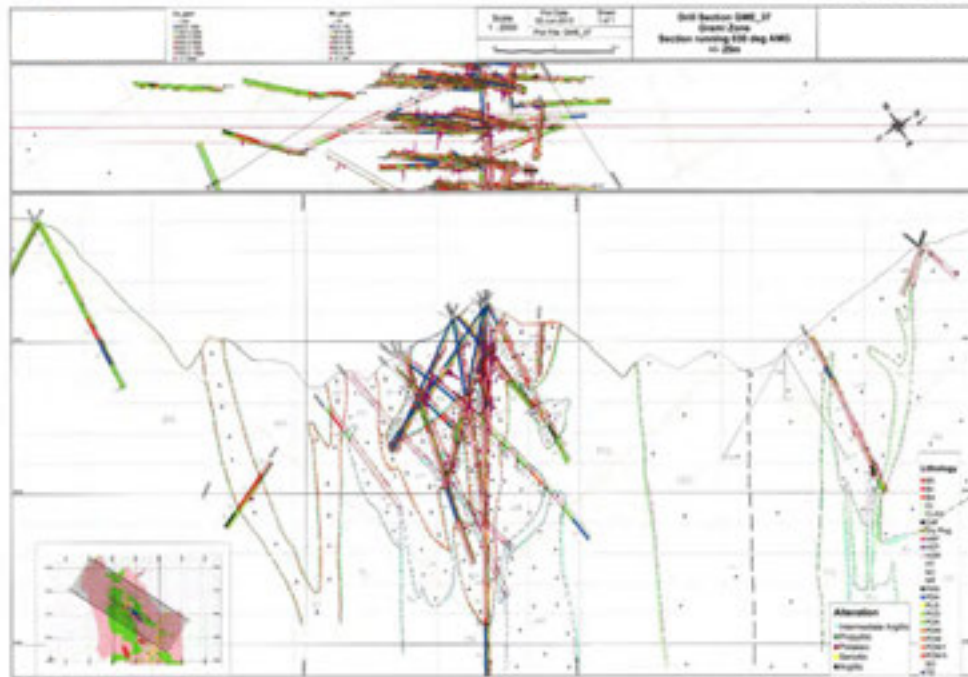
**Figure 7-9: Geologic Cross Section GME\_64\_Gremi**



Source: Era, 2016

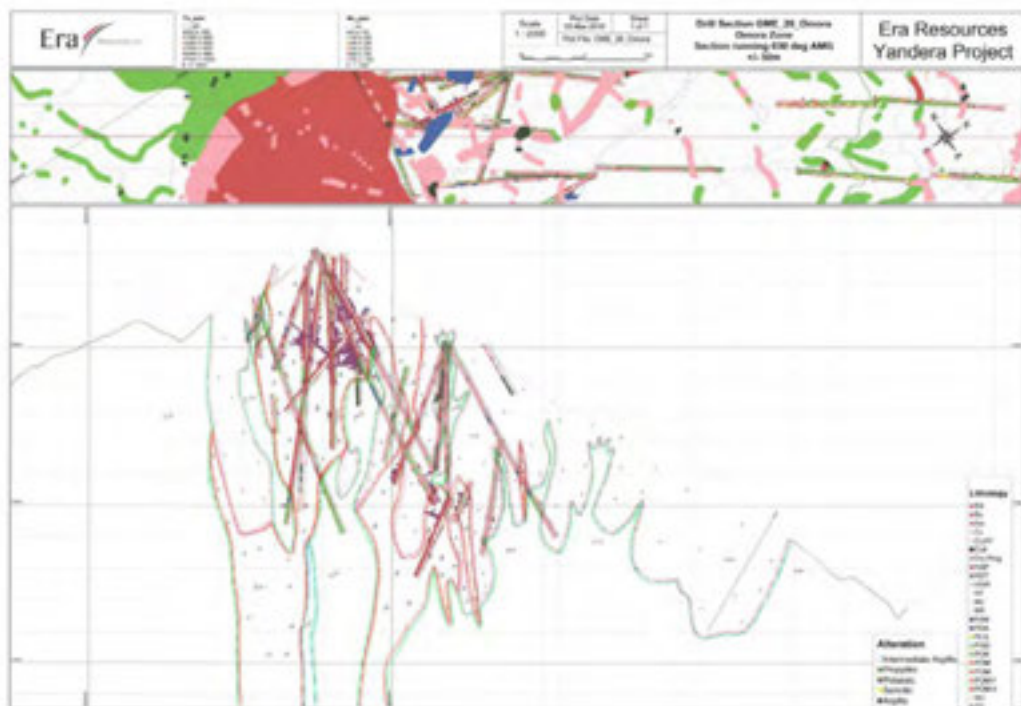
**Figure 7-10: Geologic Cross Section GME\_46\_Gremi**





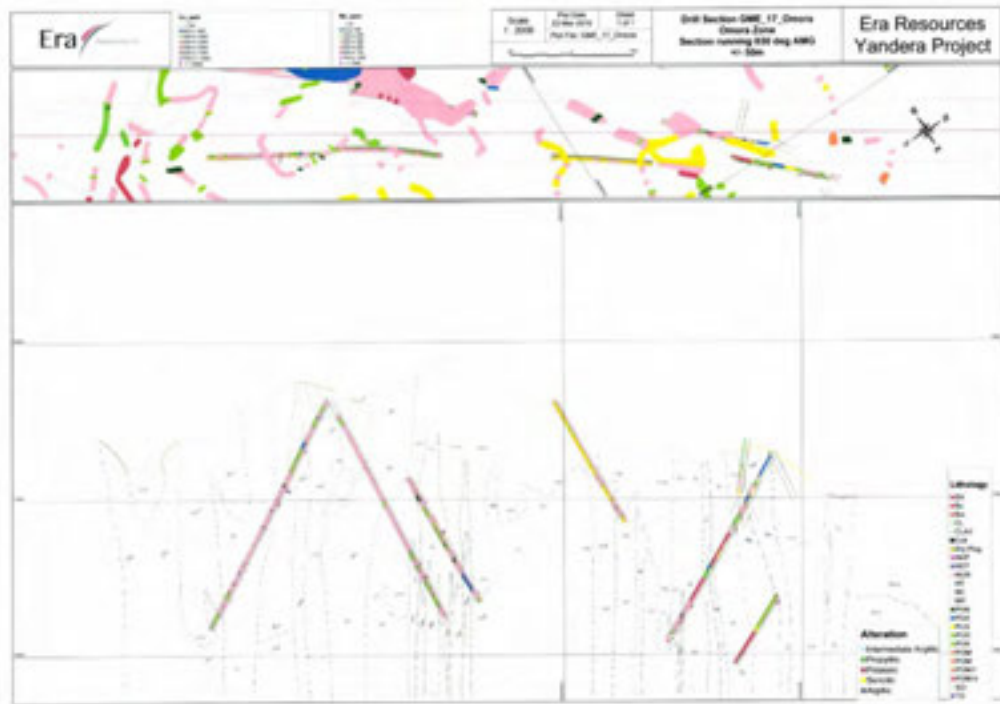
Source: Era, 2016

**Figure 7-11: Geologic Cross Section GME\_37\_Gremi**



Source: Era, 2016

**Figure 7-12: Geologic Cross Section GME\_26\_Omora**



Source: Era, 2016

**Figure 7-13: Geologic Cross Section GME\_17\_Omora**



## 8 Deposit Types

---

### 8.1 Mineral Deposit

In general, terms, the mineral system could be classified as a porphyry copper deposit. The system has many of the characteristics of a typical porphyry system, including an association with porphyritic phases of dioritic to granodioritic intrusive phases and typical alteration assemblages associated with potassic, phyllic and propylitic altered rocks. However, there are some key differences between Yandera and typical zoned porphyry systems, including strong structural controls on mineralization and an association between phyllic alteration and elevated copper grades.

### 8.2 Geological Model

The porphyry system at Yandera is hosted in late intrusive phases and structures that disrupt the Bismarck granodiorite. Mineralization appears locally controlled by porphyritic dacite and associated intrusive breccia bodies. The occurrence of these intrusive bodies and later alteration appears to be controlled by a strong northwest trend that intersects and/or is intersected by north and northeasterly trends. Higher-grade copper mineralization appears to be concentrated near the intersection of these trends, such as at Imbruminda, within broader zones of potassic and phyllic alteration.



## 9 Exploration

### 9.1 Relevant Exploration Work

Typical exploration work at Yandera consists of surface mapping and sampling, with the results being used to generate drill targets. Previous campaigns have collected geophysical data, mostly airborne, although there was an IP survey in 2009. Some of the previous explorers, such as Kennecott, BHP and Amex, excavated “contour” trails across selected ridges to expose weathered bedrock, which they subsequently mapped and sampled. Regional exploration activities by various predecessors are presented in Figure 9-1.

Exploration activities by Era between 2015 and February 2017 include: a surface mapping and sampling campaign, presented in Figure 9-2, with a focus on filling gaps in coverage of geochemical sampling at the periphery of the resource north and east of the Dimbi area; additional geochemical coverage northwest of the Gamagu area; and, mapping and sampling exposures in the Benbenubu and Omora areas.

Recent exploration has been within EL 1335 and focused at the periphery of the existing resource but included some exploration at the Pomeia prospect. Recent mapping and sampling campaigns have focused on fresh rock outcrops exposed in the drainages in these areas to collect the highest quality surface data available

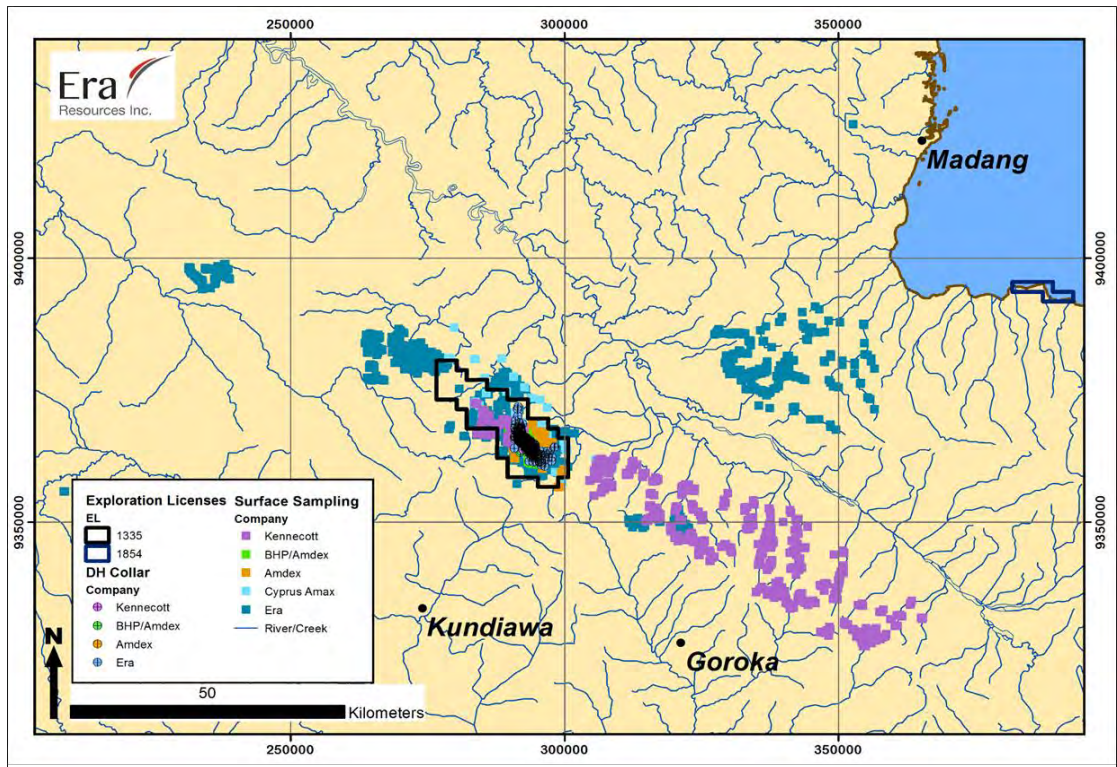
### 9.2 Sampling Methods and Sample Quality

Most of the surface samples in the recent campaigns have been collected as “grab” or “chip” samples and/or “channel” samples. In the case of a grab or chip sample, a geologist, using a hammer and chisel, would collect enough exposed rock to obtain about a kilogram of material from the outcrop. In the case of channel samples, geologists would collect chips of material across specified horizontal lengths (commonly between 1.5 and 10m) of an exposure at chest to waist height so that there was at least a kilogram of material. As such, analytical results from rocks should be representative of a localized average.

One of the biases of focusing mapping and sampling efforts in the drainages is that in some instances the better mineralized material may be eroded at a higher rate than unmineralized material. Thus, the Inferred amount of mineralization in some locations might not be representative.

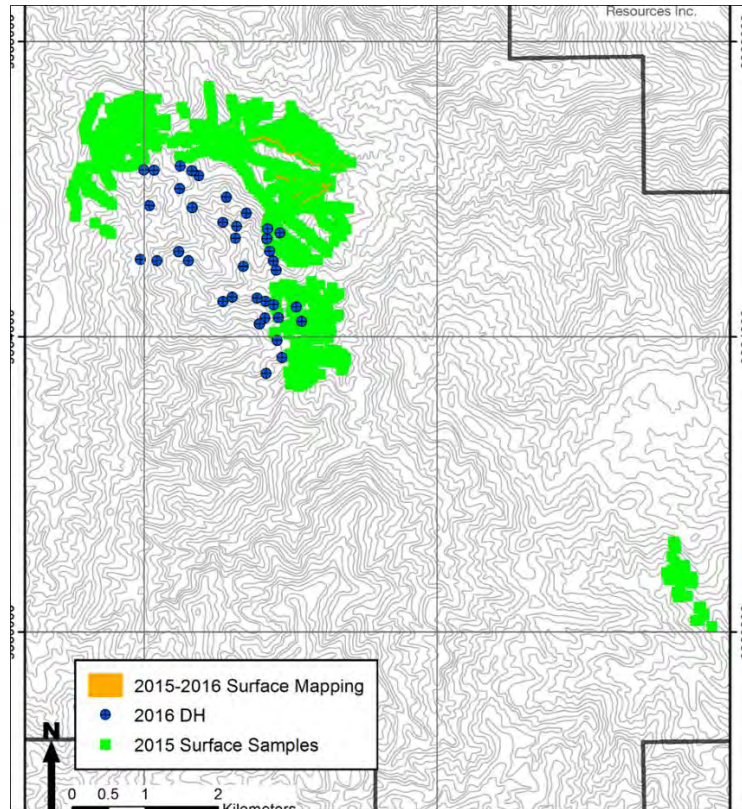
In general, sampling over the known resource area has been thorough, although there are some 300m or greater sampling gaps in the Frog, Rima and Imbruminda areas. Soil samples collected by BHP and Amdex over the Gremi area were collected with relatively dense sample spacing along contours lines (~7m) that were of the order of 100m apart. Sampling along contours across other portions is less dense with samples along contours of the order of 50 to 60m apart with sampling lines over 200m apart in some areas. Outside of the resource area, sample density decreases or “is less”.





Source: Era, 2015

**Figure 9-1: Regional Exploration Work by Company**



Source: Era, 2016

**Figure 9-2: Era 2016 Surface Exploration**

### 9.3 Significant Results and Interpretation

Re-examination of geophysical data in 2014 and 2015 resulted in the generation of a number of regional targets at intersections of linear features observed in magnetics, radiometrics, topography and geology. Using an exploration model emphasizing the importance of structural trends in this mineral system, these intersections may be more prospective than previously understood. Results from 2015 work at the Pomeia prospect, where there are some intersecting linear trends, showed high-grade, and bornite-dominated, copper mineralization associated with structures and what appear to be tabular zones of breccia and later intrusives.

Mapping and sampling in 2015 and 2016 in the Dimbi area resulted in identification of copper in soil anomalies on a southeasterly trend from known Dimbi mineralization. Drill tests of this area showed that copper mineralization continues to the southeast of the Dimbi-South area. Surface work and drill data are insufficient to close mineralization to the southeast of this trend. Surface work in the Dimbi area also suggests that potential for mineralization to the immediate northeast of the resource is low.

Mapping and sampling in the Omora and Benbenubu areas in 2015 showed some continuity in copper anomalies not previously recognized. This surface work generated a number of drill targets that were later shown to contain copper mineralization that became part of the 2016 resource.

Sampling in the Kauwo area to the northwest of Imbruminda showed a significant surface copper anomaly trending to the northwest of both the 2015 and 2016 resource limits. This target was not drill tested but appears prospective for extending the resource to the northwest.

The author considers the surface exploration and sampling as adequate to define geological and mineralogical information to assist in drilling target definition; and considers them appropriate exploration techniques for the geology and the terrain.

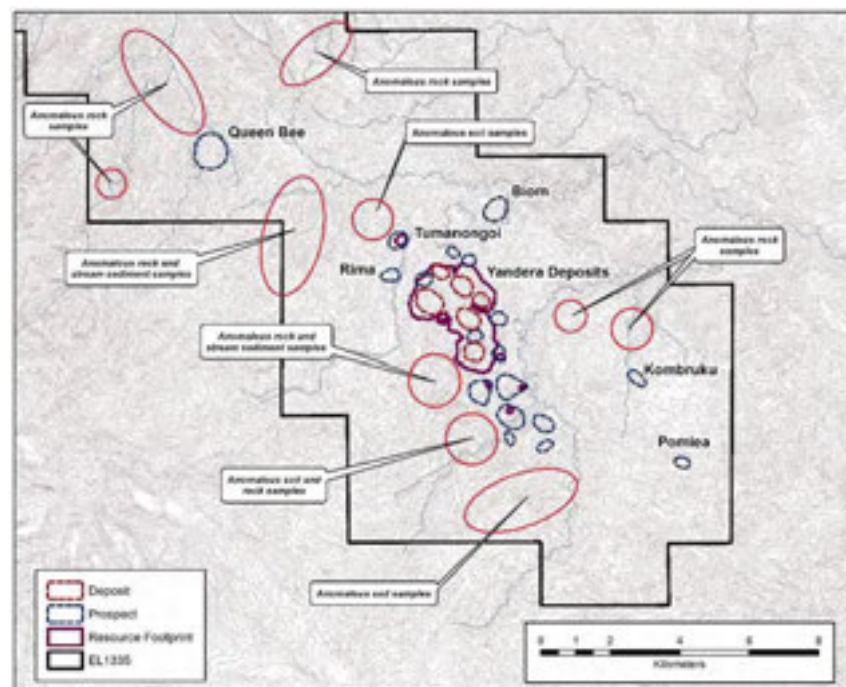


Figure 9-3: Resource Potential along the North West / South East Strike



## 10 Drilling

### 10.1 Type and Extent

All drillholes at the Project and, therefore, all the drillholes used in the resource estimate, were drilled with a diamond core rig. Most of the drilled length was completed with triple-tube HQ tooling with a nominal 6.1cm core diameter. The drillers reduced to triple-tube NQ tooling (4.5cm diameter) where dictated by ground conditions. Typically, the planned total depths of the drillholes did not exceed the pullback capability of the rigs advancing HQ tooling and, therefore, the ground conditions were the only factor that would require NQ coring.

The drilling contractor for the 2012 to 2014 programmes was Quest Exploration Drilling (QED), based in Lae, PNG. For the 2016 drilling programme, Titeline Drilling Ltd., also based in PNG, was contracted. Table 10-1 summarizes all recent project area drilling, with the main resource areas highlighted. The project drillhole collar locations are shown in Table 10-1

Table 10-2 presents Era’s 2012-2014 drillholes by purpose and deposit area. Most of these drillholes were completed in 2012, and many of them were for geotechnical engineering purposes, and are not directly applicable to the Mineral Resource Estimation (MRE).

As of 2015, Era had completed 471 drillholes totalling 138,428m of drilled length. Since the previous MRE (SRK, 2015), Era completed a drilling programme in 2016 that added 50 drillholes and 10,099m of drilled length to the project database. The 2016 programme, summarized in Table 10-3, focused on resource infill drilling and added 43 drillholes with logged geology and assay data to the project data set. The 2016 geotechnical drillholes are not included in the geological model or resource estimation presented in this Report.

**Table 10-1: Summary of Yandera Drilling by Deposit Area and Property Owner**

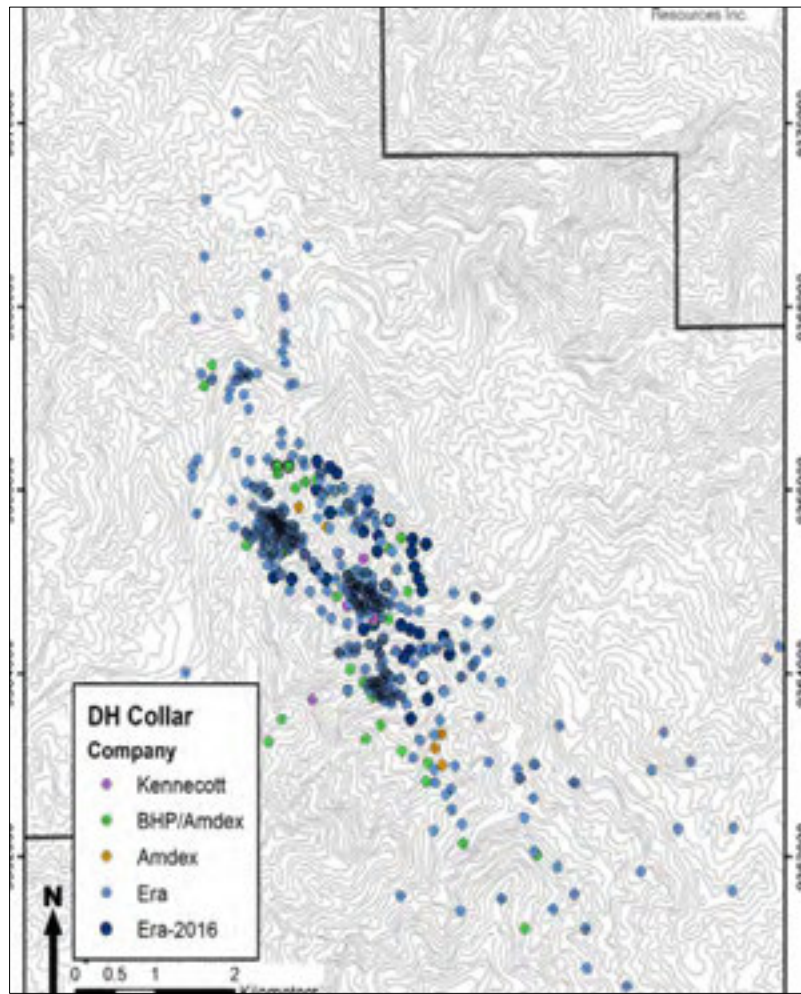
Prospect	Owner	Drillholes	Total Length (m)
Benbenubu	Era	3	704
Dengru	Era	4	926
Dimbi	BHP/ Amdex JV	7	2,187
Dimbi	Era	31	10,238
Dimbi	Era	9	1,874
Dirigi	BHP/ Amdex JV	4	1,667
Dirigi	Era	19	6,663
East Gremi	Era	4	667
Frog	BHP/ Amdex JV	2	406
Frog	Era	23	2,891
Gamagu	Era	2	407
Gremi	Kennecott	7	1,017
Gremi	BHP/ Amdex JV	26	8,583
Gremi	Era	98	32,453
Gremi	Era	2	408
Imbruminda	Kennecott	2	361



Prospect	Owner	Drillholes	Total Length (m)
Imbruminda	BHP/ Amdex JV	27	8,913
Imbruminda	Era	144	52,258
Imbruminda	Era	7	1,190
Kauwo	Era	1	167
Kombruku	Era	12	3,509
Mangiai	Era	9	1,158
Mumnogoi	BHP/ Amdex JV	8	2,625
Mumnogoi	Era	12	3,581
Omora	Kennecott	2	593
Omora	BHP/ Amdex JV	16	6,160
Omora	Era	93	26,370
Omora	Era	9	1,864
Ongoma	Era	2	77
Queen Bee	Era	1	39
Rima	Era	4	1,005
South Dimbi	Era	9	1,893
TAI-YOR	Era	21	4,186
Windi	Era	2	300
Yandera	Kennecott	1	305
Yandera	BHP/ Amdex JV	2	402
<b>Database Total</b>		<b>625</b>	<b>188,045</b>
<b>Model Area</b>		<b>588</b>	<b>180,367</b>

Source: SRK, 2016





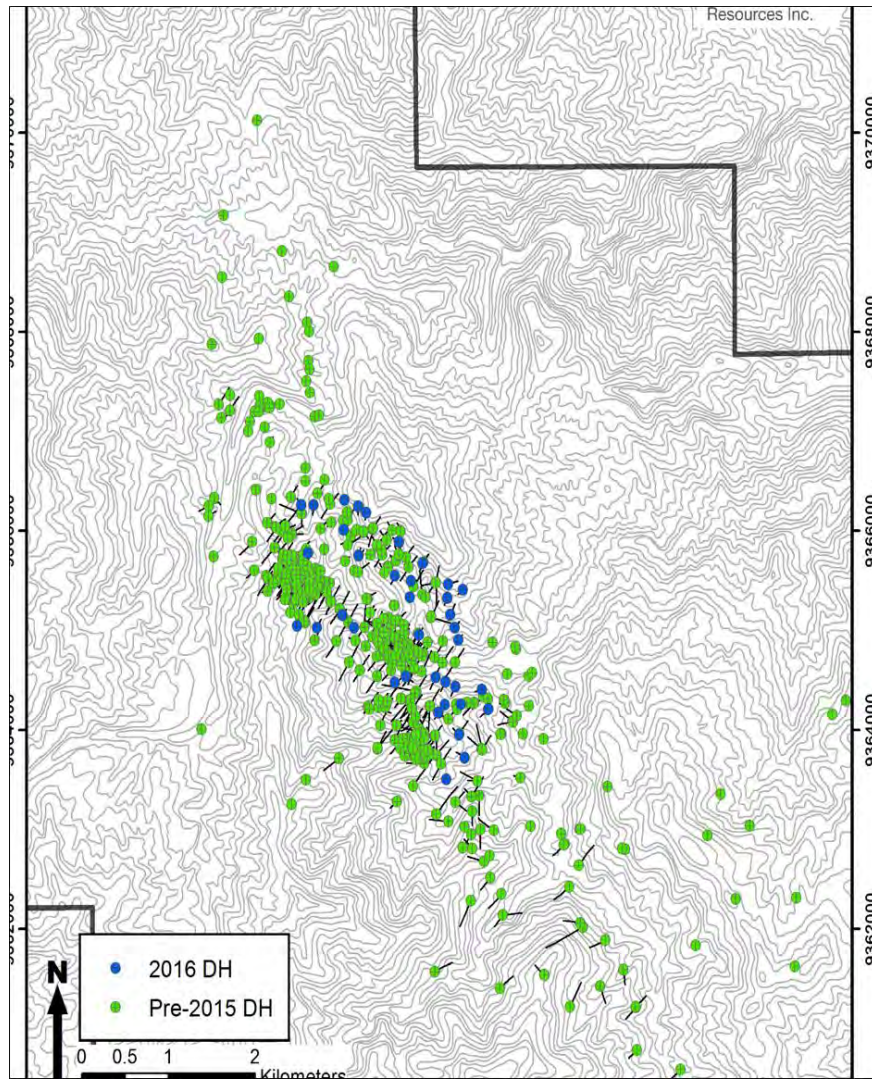
Source: Era, 2016

**Figure 10-1: Location of Drillhole Collars by Company**

**Table 10-2: 2012-2014 Era Drilling Programmes**

Year	Purpose	Area	Drillholes	Length (m)
2012	Resource, n = 50	Dirigi	2	429
		Gremi	17	3,788
		Imbruminda	19	5,857
		Omora	11	3,139
		Tai-Yor	1	356
	Geotechnical	Frog, Others	13	843
	Exploration	Dirigi, Others	20	7,311
<b>2012</b>	<b>Total</b>		<b>83</b>	<b>21,722</b>
2013	Exploration	Dimbi	9	1,833
2014	Exploration	Rima	4	1,005
<b>2012 – 2014</b>	<b>Total</b>		<b>96</b>	<b>24,560</b>

Source: SRK, 2015



Source: Era, 2016

**Figure 10-2: Recent Era Drilling from 2012 to 2014**

**Table 10-3: Era 2016 Drilling Programmes**

Year	Area	Drillholes	Length (m)
Resource	Dimbi	22	4,405
	Gremi	9	1,827
	Imbruminda	4	818
	Omora	8	1,868
<b>Total, 2016 Resource Drilling</b>		<b>43</b>	<b>8,919</b>
Geotechnical	Dimbi	3	602
	Imbruminda	4	579
<b>Total, 2016 Geotechnical Drilling</b>		<b>7</b>	<b>1,181</b>
<b>2016 Drilling Programme</b>		<b>50</b>	<b>10,099</b>

Source: SRK, 2016

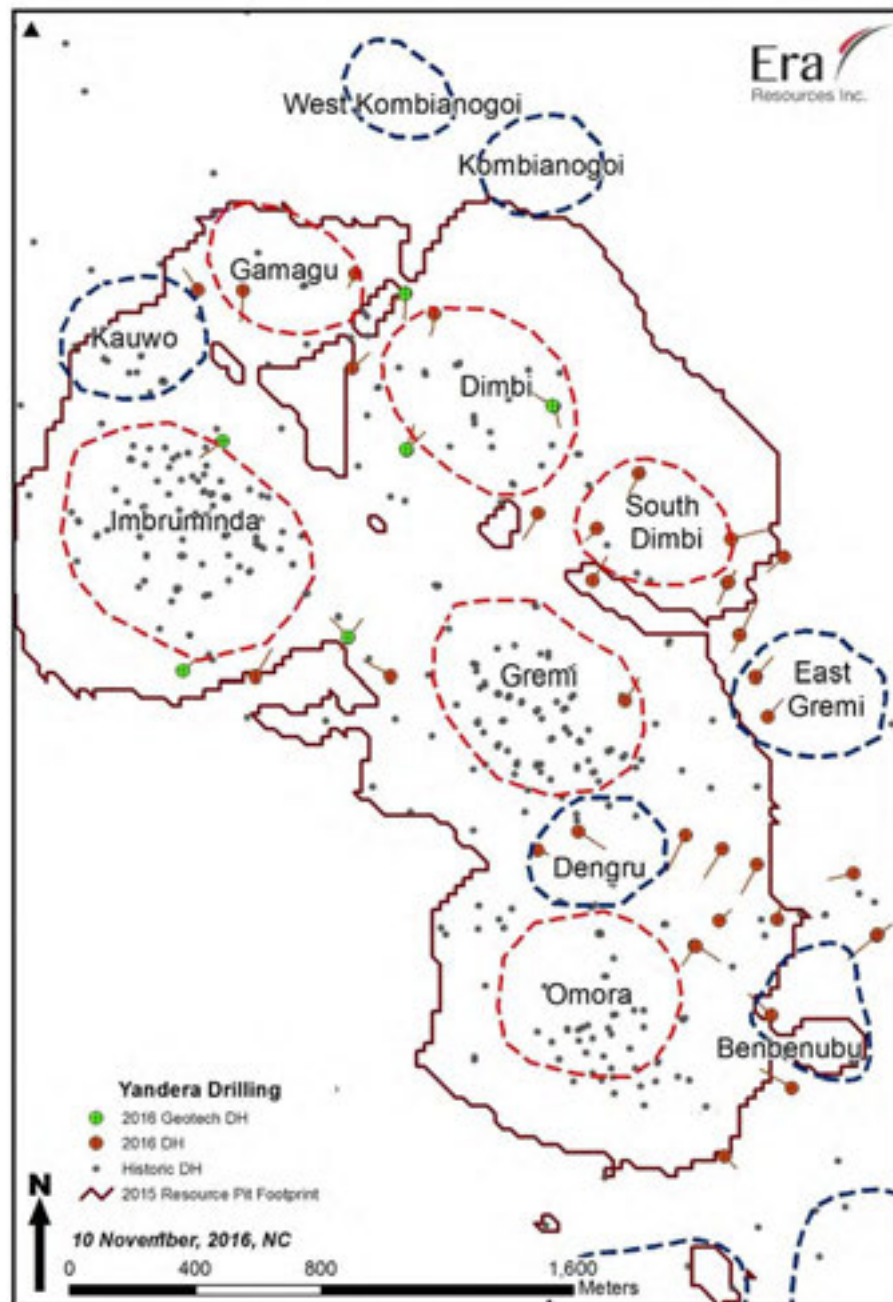


Figure 10-3: Era 2016 Drilling Summary

### 10.1.1 Drilling Results - 2016

- Good mineralization at South Dimbi, extending beyond resource footprint
- Continuity of mineralization at Dengru, north of Omora
- Extension of mineralization at Benbenubu
- Continuity between Dimbi and Gamagu
- Continuity between Imbruminda and Gremi



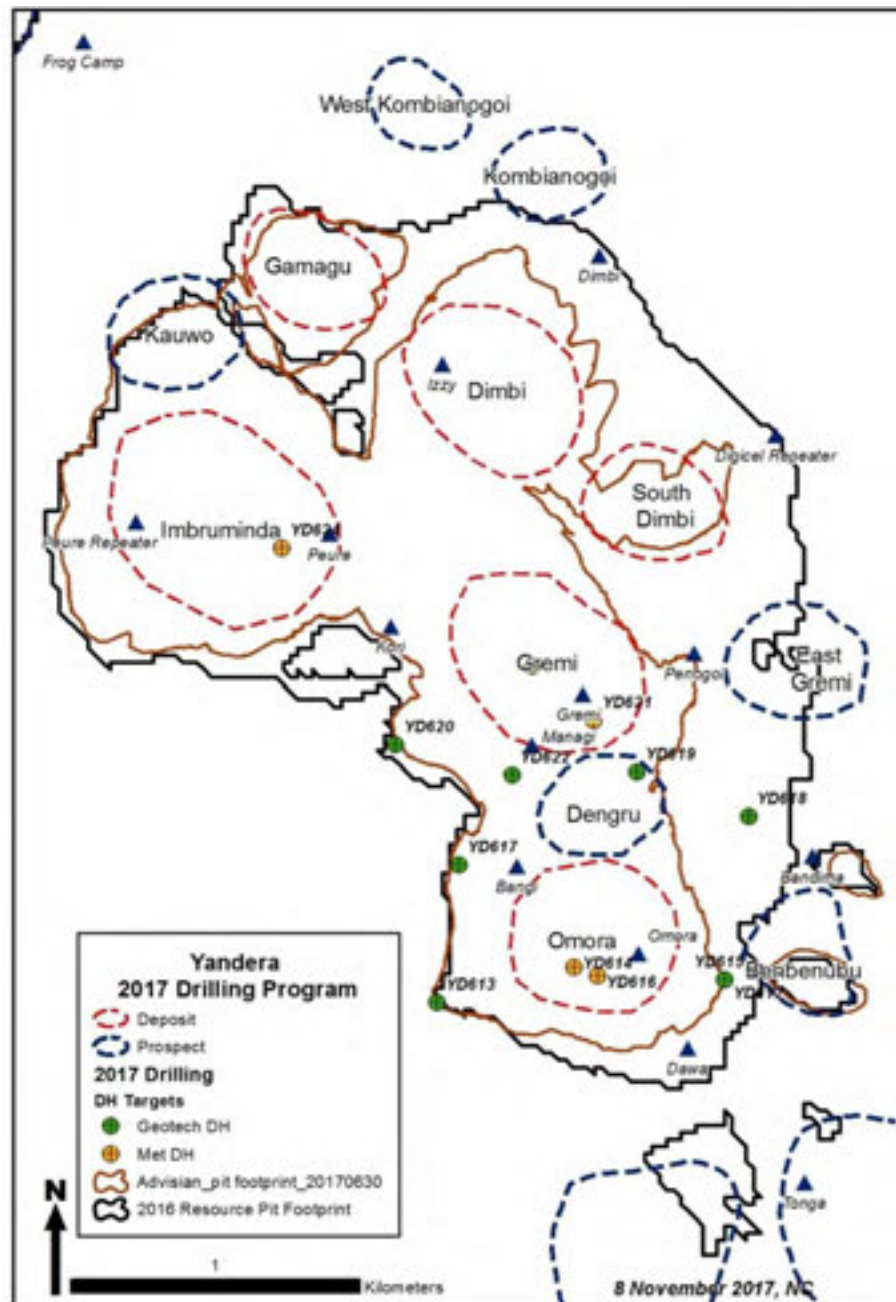


Figure 10-4: Era 2017 Drilling Summary

### 10.1.2 Drilling Program – 2017

- Metallurgical Drilling : 761.5m, 5 holes
- Geotechnical Drilling : 1,770.8m, 8 holes

### 10.1.3 Drilling Results – 2017

- Collected metallurgical samples from Omora, Gremi, and Imbruminda with focus on hypogene phyllic alteration



- Collection of geotechnical data at western margin of model pit
- Completion of packer tests in geotechnical and most metallurgical holes to collect hydrologic transmissivity and conductivity data

## 10.2 Procedures

The procedures documented in this section are sourced from internal documents provided by Era (2014) with an addendum by Era (2016) and additional information from project staff and SRK's original site visit.

Drillhole collar elevations in a number of instances differ from native topography because extensive cut and fill is required to build drill pads. A PNG surveyor using Differential GPS completed collar surveys for most holes; however, holes drilled in 2013 and 2014 were surveyed using a handheld GPS. Era used Differential GPS to survey all holes drilled in 2016.

Collar elevations were validated against the high-resolution topographic surface and drillhole locations before resource estimation began.

Drillholes were oriented at surface with a compass. Downhole surveys were collected with a Reflex multi-shot tool. Deviation in the drillhole was tracked while drilling to monitor for anomalies or suspicious measurements.

Drillhole collar elevations in a number of instances differ from native topography because extensive cut and fill is required to build drill pads. A PNG surveyor using Differential GPS completed collar surveys for most holes; however, holes drilled in 2013 and 2014 were surveyed using a handheld GPS. Era used Differential GPS to survey all holes drilled in 2016.

Collar elevations were validated against the high-resolution topographic surface and drillhole locations before resource estimation began.

Drillholes were oriented at surface with a compass. Downhole surveys were collected with a Reflex multi-shot tool. Deviation in the drillhole was tracked while drilling to monitor for anomalies or suspicious measurements.

Core is typically drilled in 3m or 1.5m runs and placed in core boxes after the core is oriented. At the drill site, geotechnical and structural logging is completed and includes a summary of lithology. In case of disturbance during transport to the logging facility, the summary log is used as a guide to restore the core samples to the original configuration. The core box numbering and length intervals are verified at the drill site, and again when the boxes are laid out in sequence at the logging facility. The core is transported by helicopter to the Frog Camp logging facility.

At the Frog Camp logging facility, high-resolution photography of the core is completed and verified for quality before logging. Geologists complete detailed geological logging. The logging geologist marks a cut line on the core to ensure unbiased sampling.

Drill sample intervals are determined by the logging geologist and assigned a sequential sample number with a "MY" prefix. Sample intervals and reference samples are marked with aluminium tags in the core boxes. Nominal sample intervals for the 2016 drilling programme were 3m or shorter to reflect changes in material type.



The 2012 to 2014 drilling programmes had 2-m nominal sample length, and the rest of the historical data set had 3-m samples. After every 10<sup>th</sup> or 20<sup>th</sup> drill core sample, depending on the drilling programme, a reference sample is included in the sample sequence.

For 2m sample intervals, the insertion rate is one reference sample per 20 drill core samples but for previous work, when the typical sample intervals were 3m, one reference sample was inserted after every 10<sup>th</sup> drill core sample. The 2016 programme had one reference sample per 10 drill samples, with an additional sample identification code reserved for the coarse reject duplicate of every 20<sup>th</sup> drill sample.

All core is saw split, and all equipment including core saw is cleaned after each sample interval is cut. After cutting, the left side of core is sampled and the right side is retained for archival purposes. After the analytical data is received, geologists complete advanced geological logging and technicians photograph the half core.

All analytical results were sent to Era's Madang office and select technical personnel. Data are imported to Maxwell Geoservices Datashed software, which includes data validation and reporting tools. Geological data are also added to the Datashed database after tabulation from paper drill logs.

Although there is agreement in lithology nomenclature through the drilling programmes, some minor intrusive units have been identified differently between some of drilling campaigns. Generally, these differences can be rectified with the use of core photography.

Alteration identified in the logging is not as consistent as the lithology. There are several factors that have led to complications, including inconsistent methodology of categorizing alteration for logged intervals and over-interpretation on the drill logs. Initially, the alteration described in historic logging was generally focused on the strongest style of alteration visible in the core, which did not distinguish early alteration from later alteration. Later drilling campaigns attempted to differentiate the sequential alteration assemblages although this resulted in an over-estimation of the abundance of interpreted early potassic alteration. In the later drilling campaigns that categorized the age relationships of the alteration, the alteration category that appears to have the least amount of interpretation is the Alteration 2.

### **10.3 Interpretation and Relevant Results**

All relevant drillholes in the database were considered for geological interpretation and resource estimation. The author considers the drilling method and procedures appropriate for the geology and style of mineralization. The drilling procedures generate samples that are sufficient for use in resource estimation.



## 11 Sample Security, Preparation and Analysis

### 11.1 Security Measures

Sample security and quality assurance includes Era Chain of Custody and supervision of drill core from initial production through sample shipment. From the drill site, Era geologists or technicians transport core to the Frog Camp core yard for detailed logging followed by saw splitting and sampling the left side. Samples are prepared at the Intertek laboratories in Frog Camp and Lae. Prepared samples are usually transported to Lae via road by Era but occasionally other carriers are contracted for sample shipment.

### 11.2 Sample Preparation for Analysis

Intertek at the Frog Camp and Lae preparation laboratories completed drillhole sample preparation. Intertek is an international analytical corporation and is independent from Era and any of its affiliates. Intertek's Frog laboratory is managed and staffed by Intertek. Initial crushing was completed on site to reduce shipping costs.

The sample preparation code for drill core samples is SP123 and included:

- At the Frog laboratory:
  - initial crushing stage of 100% passing 6mm;
  - secondary jaw crush to 100% passing 10mesh (2mm);
  - using a riffle splitter, a 700 to 900g split was taken from the crushed coarse reject;
  - two coarse reject splits were generated from every 20<sup>th</sup> core sample; and
  - Select core samples were used for specific gravity determination.
- At the Lae preparation laboratory:
  - the coarse split was pulverized to 95% passing -200mesh (75 µm) in a ring and puck mill; and
  - A sample of mass between 250 and 300g was taken to send to Intertek's laboratory in Jakarta for analysis.

### 11.3 Sample Analysis

Intertek in Jakarta, Indonesia or in Townsville, Australia completed geochemical drillhole sample analysis. These laboratories are ISO 17025 accredited and meet international quality standards.

For determination of the base metals, 4-acid digestion and multi-element Inductively Coupled Plasma (ICP) Atomic Emission Spectroscopy (AES) analysis of a 0.5g charge was completed. In Intertek's laboratory certificates, the reported method code is 4A/OE/MS for 36 element multi-element analysis. Gold fire assay method FA50 on a 50-g charge was used for gold determination. Although the lower Method Detection Limit (MDL) for this gold determination is listed as 1ppb (0.001ppm), reported results indicate a higher MDL of 5ppb (0.005ppm). MDLs and CoGs of the elements of interest are summarized in Table 11-1.





In 2016, Era used the specific gravity determination method detailed by the Australasian Institute of Mining and Metallurgy (AusIMM) (2001), and included analysis of reference samples of intact granodiorite with known specific gravity values.

**Table 11-1: Method Detection Limits for Key Elements**

Description	Copper (ppm Cu)	Molybdenum (ppm Mo)	Sulphur (% S)	Gold FA (ppm Au) (2)
Lower MDL	1	2	0.005	0.001
Upper MDL	10,000	10,000	10	n/a
CoG (1)	1500	25.0	0.10	0.025

- 1) Economic CoG for copper is shown. Grade shell threshold values for molybdenum and gold are included.
- 2) Fire assay with gravimetric finish. The minimum value reported in the database is 0.005ppm. Gold grades of Yandera samples are much less than the upper MDL.

Source: SRK, 2015

## 11.4 Quality Assurance/Quality Control Procedures

The 2016 resource drilling programme has 2,974 primary drill samples from 43 drillholes. Sample batches by drillhole included Quality Assurance/Quality Control (QA/QC) Certified Reference Materials (CRMs) of known value and blanks and coarse reject duplicate samples for 3,568 total samples. A subset of samples was sent to a second independent laboratory for check assay analysis.

### 11.4.1 Reference Materials

There are 297 CRM samples in the 2016 drillhole assay data set. The average CRM insertion rate is every 10<sup>th</sup> drill core sample, which exceeds current industry standards. The reference samples analysed with the 2016 drill samples were from the following materials:

- OREAS 501b (n = 95, 32%).
- OREAS 502b (n = 92, 31%).
- OREAS 503b (n = 95, 32%).
- OREAS 504b (n = 15, 5%).

These CRMs are made from porphyry-hosted Cu-Au-Mo sulphide mineralization similar to that found at Yandera.

Performance of OREAS 501b through OREAS 504b materials are discussed below. Copper results are the most relevant because most of the Project's value is from copper mineralization. Molybdenum and gold are lesser components of the resource's value. Sulphur results are also presented below, because the Cu:S ratio was used as a guide for modelling oxide and defining metallurgical material types for resource reporting. Table 11-2 shows the mean values of the four elements of interest of the four CRMs. This table also includes the economic CoG of copper and grades of interest for molybdenum, gold and sulphur.

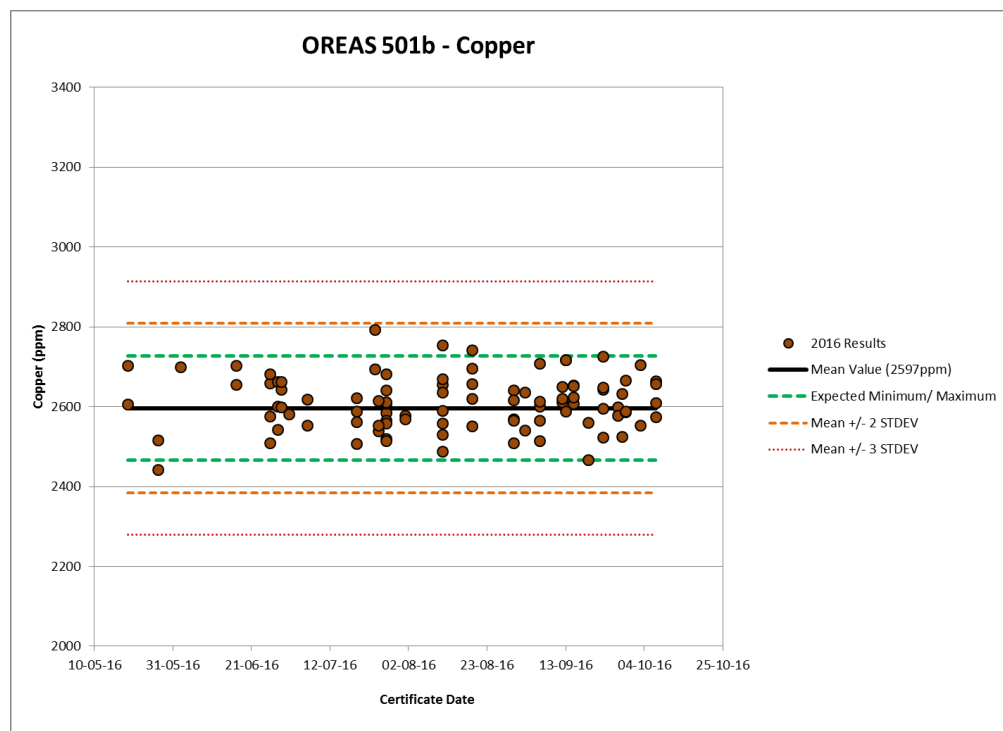


**Table 11-2: Mean Values of CRM in 2016 Drilling Programme**

CRM	Copper (ppm)	Molybdenum (ppm)	Gold (ppm)	Sulphur (%)
OREAS 501B	2,600	99	0.248	0.354
OREAS 502b	7,730	238	0.495	0.950
OREAS 503b	5,310	319	0.695	0.667
OREAS 504b	11,100	499	1.61	1.31
<b>CoG</b>	<b>1,500</b>	<b>25</b>	<b>0.025</b>	<b>0.10</b>

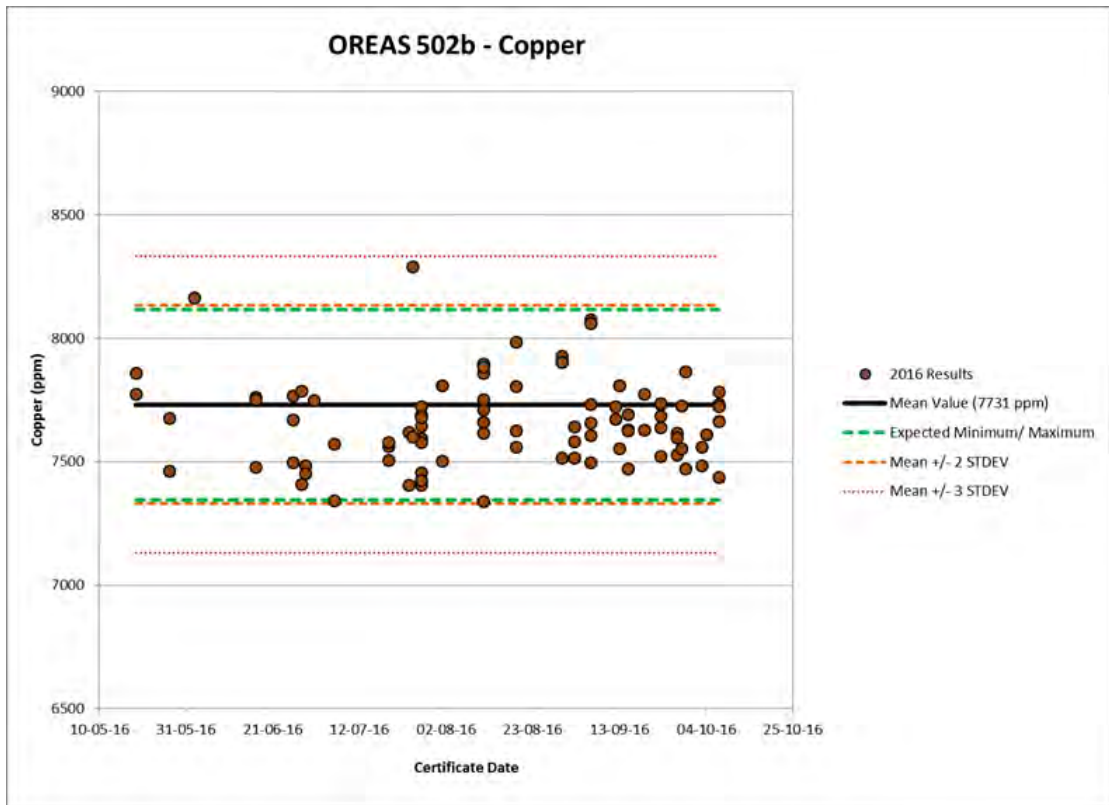
Economic CoG for copper is shown. Grade shell threshold values for molybdenum and gold are included.  
Source: SRK, 2016

The range of copper, molybdenum, gold and sulphur values in the CRM samples are appropriate to assess the analytical capability of the laboratory in the range of values typical at the Project. Copper results for the CRM are shown in Figure 11-1 to Figure 11-4.



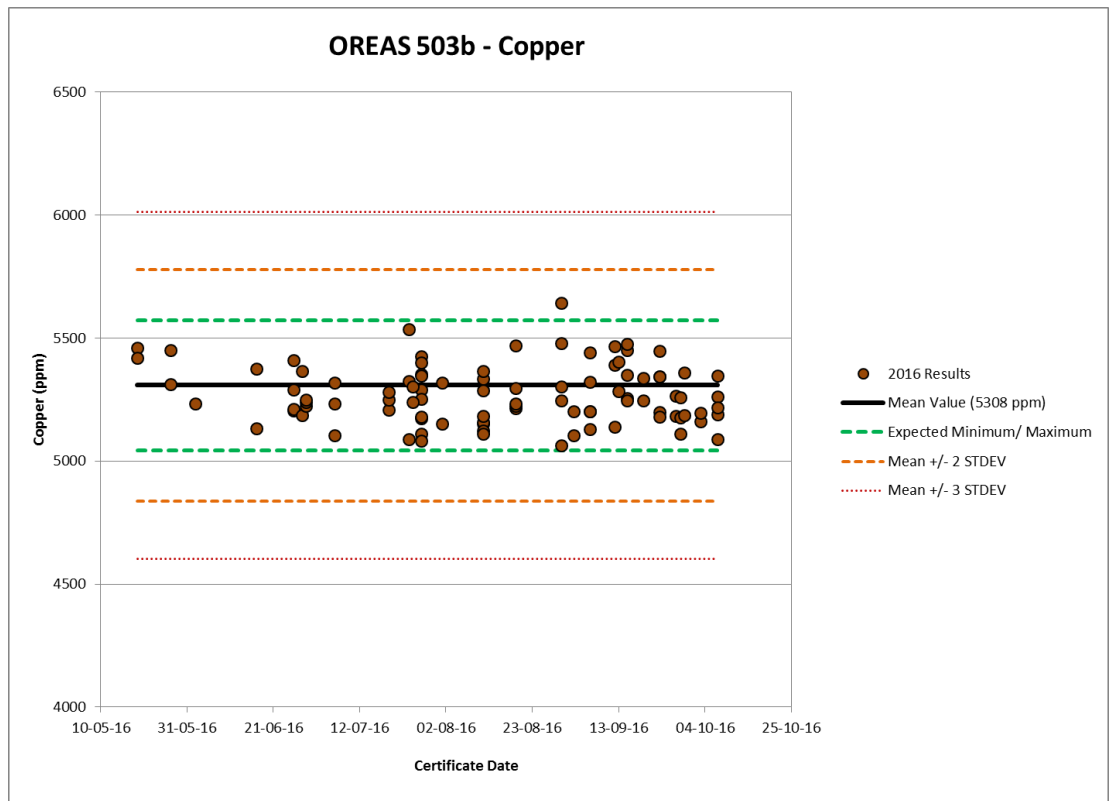
Source: SRK, 2016

**Figure 11-1: Copper Results for OREAS 501b**



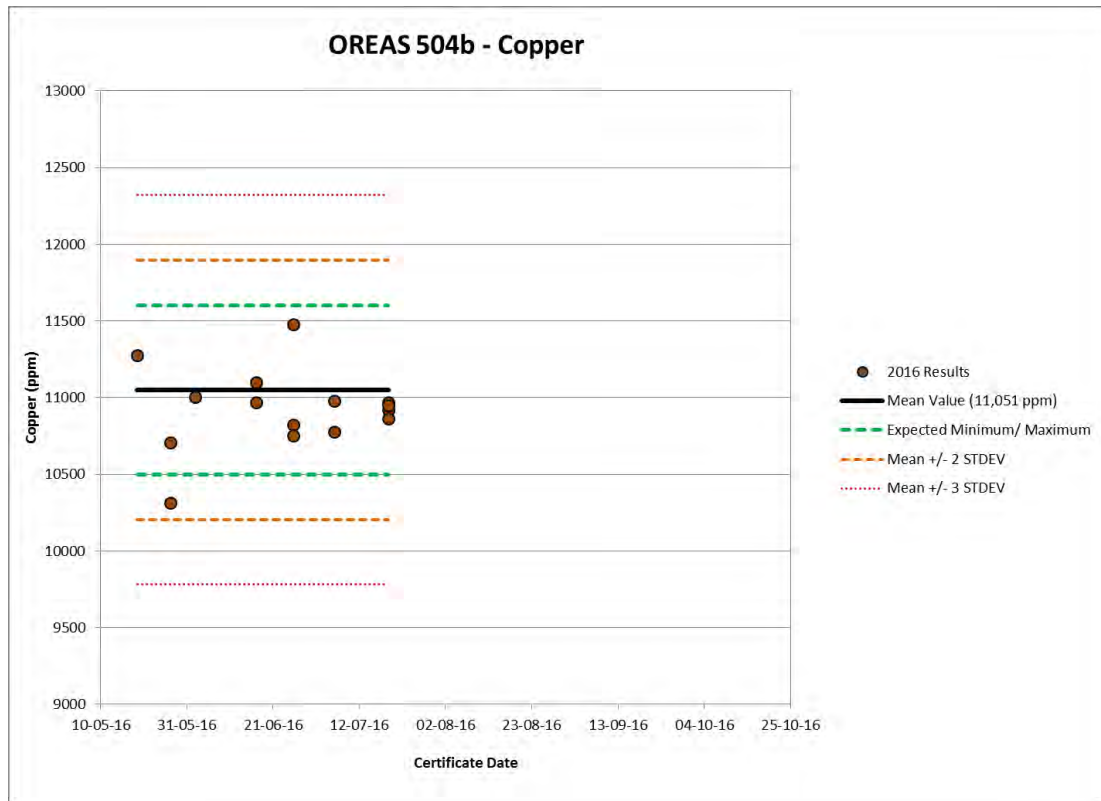
Source: SRK, 2016

**Figure 11-2: Copper Results for OREAS 502b**



Source: SRK, 2016

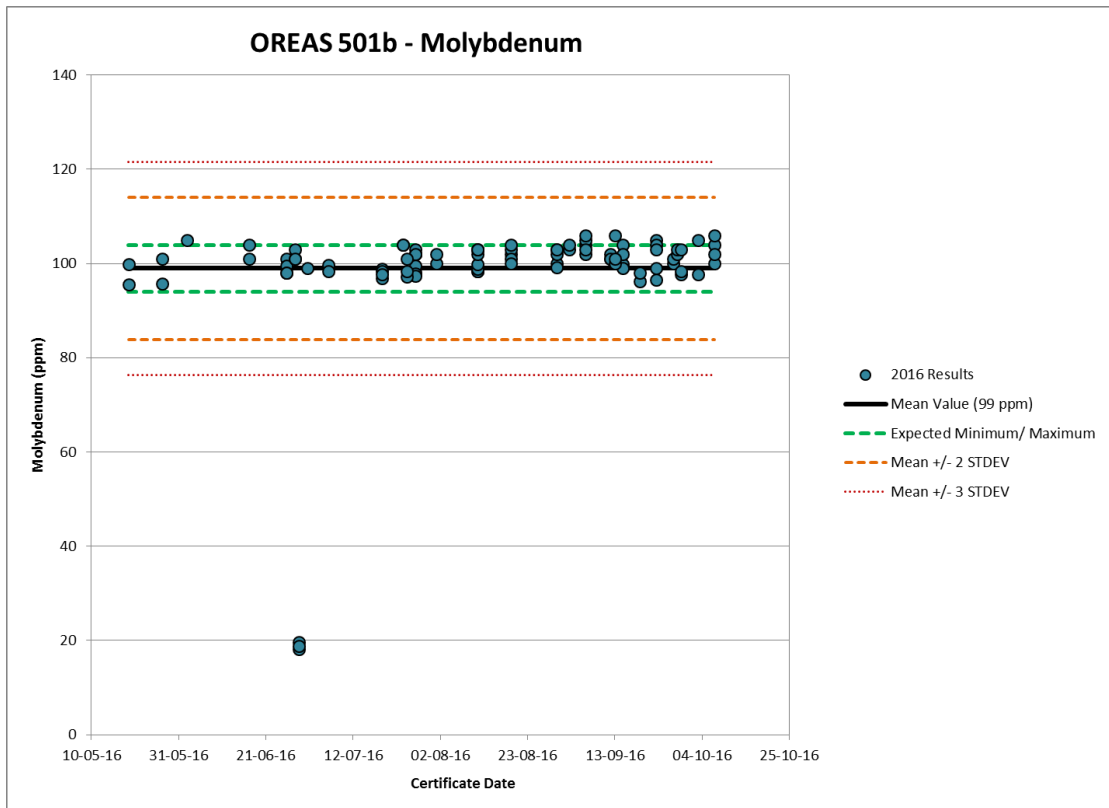
**Figure 11-3: Copper Results for OREAS 503b**



Source: SRK, 2016

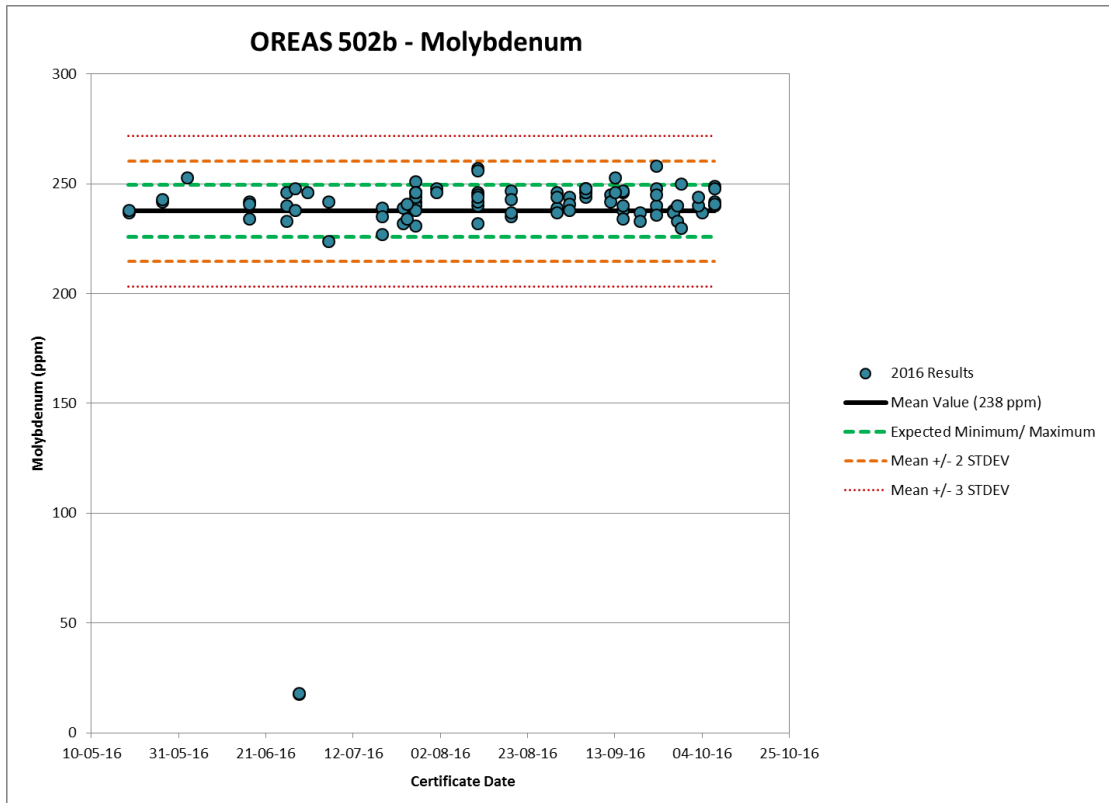
**Figure 11-4: Copper Results for OREAS 504b**

Molybdenum results are shown in Figure 11-5 to Figure 11-8. The molybdenum results indicate good performance of the CRM samples. The isolated samples with low values may indicate sample mix-ups for that analytical method, which appears to be from a different instrument than the copper values. Gold results are shown in Figure 11-9 to Figure 11-12. While most of the gold values are within acceptable limits from the certified mean value, they show more variability than the base metal values and have a slight low bias. The apparent low bias could be an artefact of decreasing precision near the lower method detection limit. The variability and low bias in gold could, instead, indicate incomplete fusion during the fire assay process. Several samples have reported gold values near the method detection limit. These results could indicate a sample mix-up at the analytical laboratory, or that the CRM used was actually blank material.



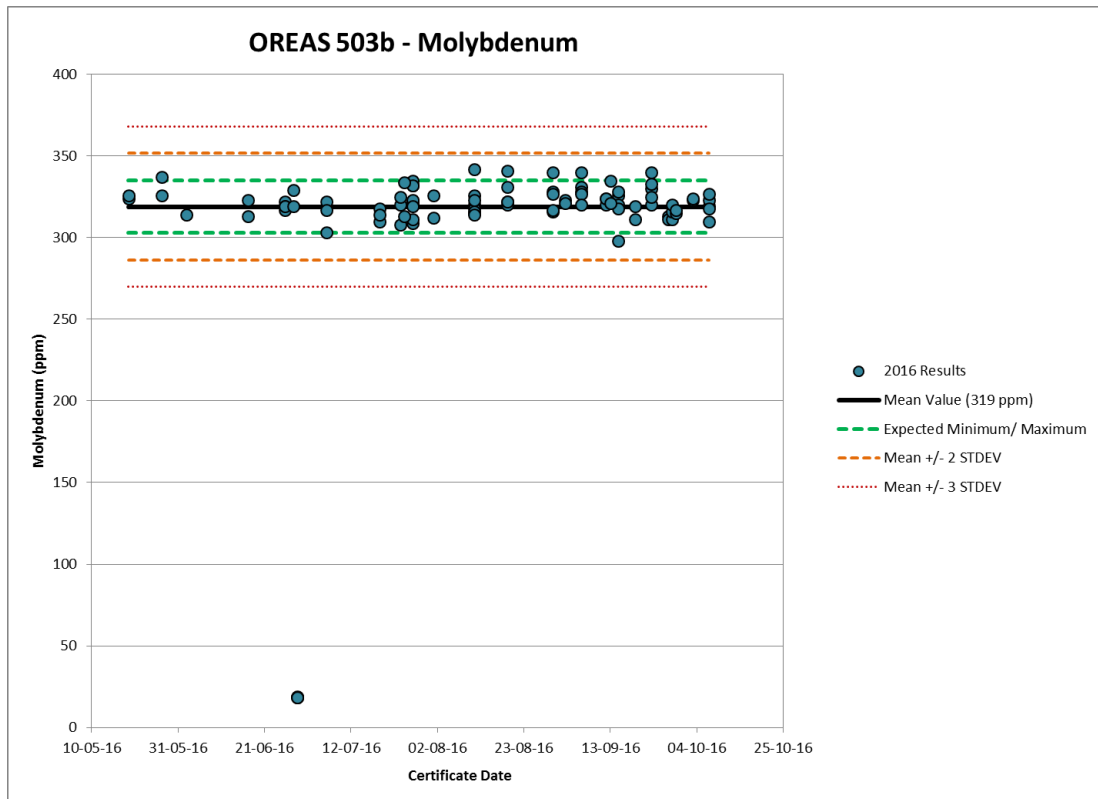
Source: SRK, 2016

**Figure 11-5: Molybdenum Results for OREAS 501b**



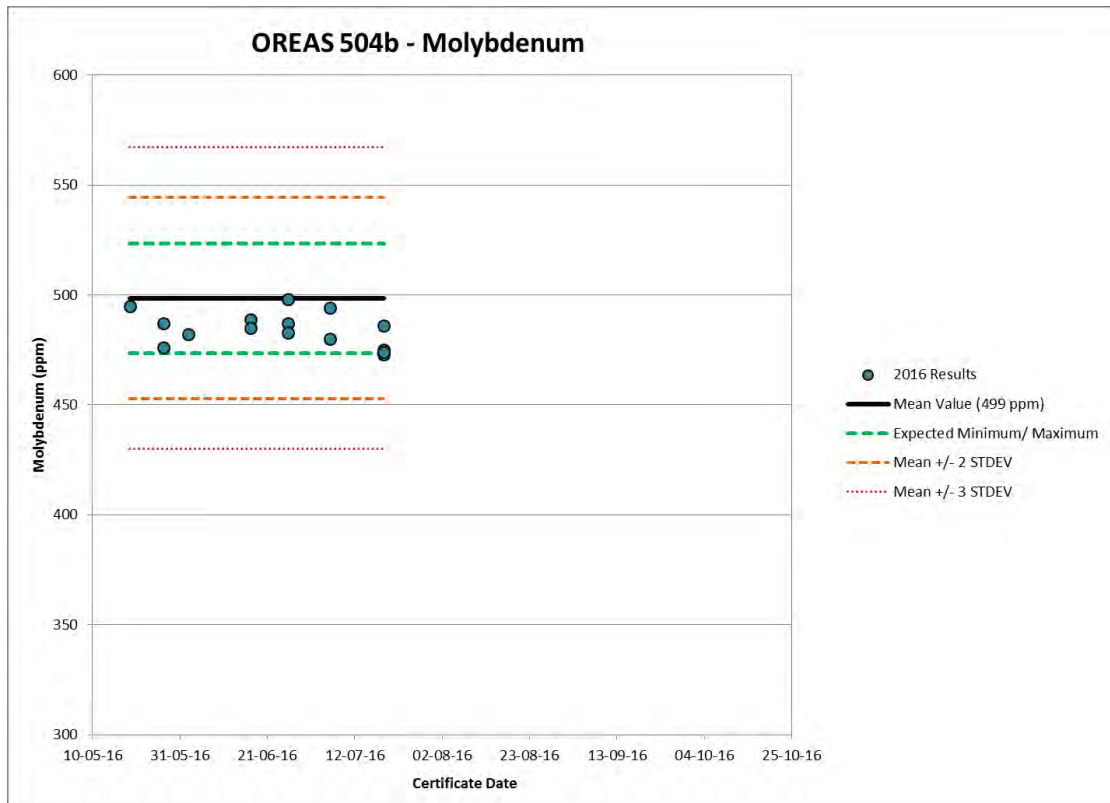
Source: SRK, 2016

**Figure 11-6: Molybdenum Results for OREAS 502b**



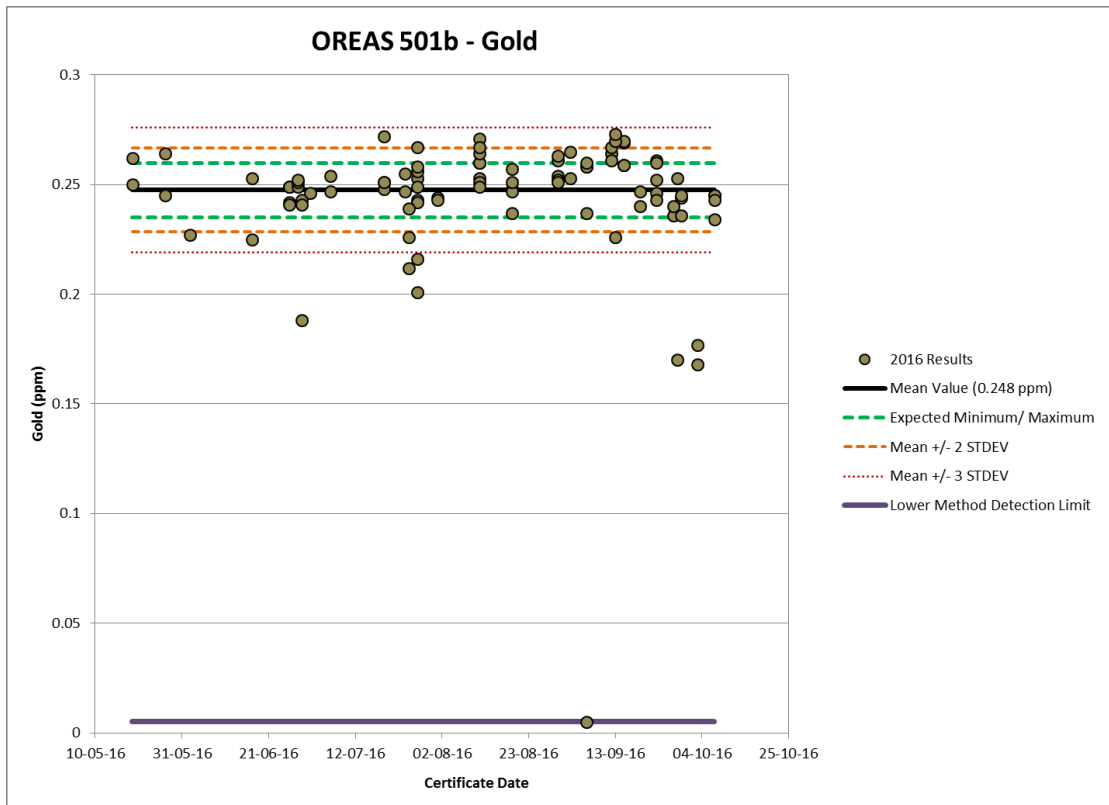
Source: SRK, 2016

**Figure 11-7: Molybdenum Results for OREAS 503b**



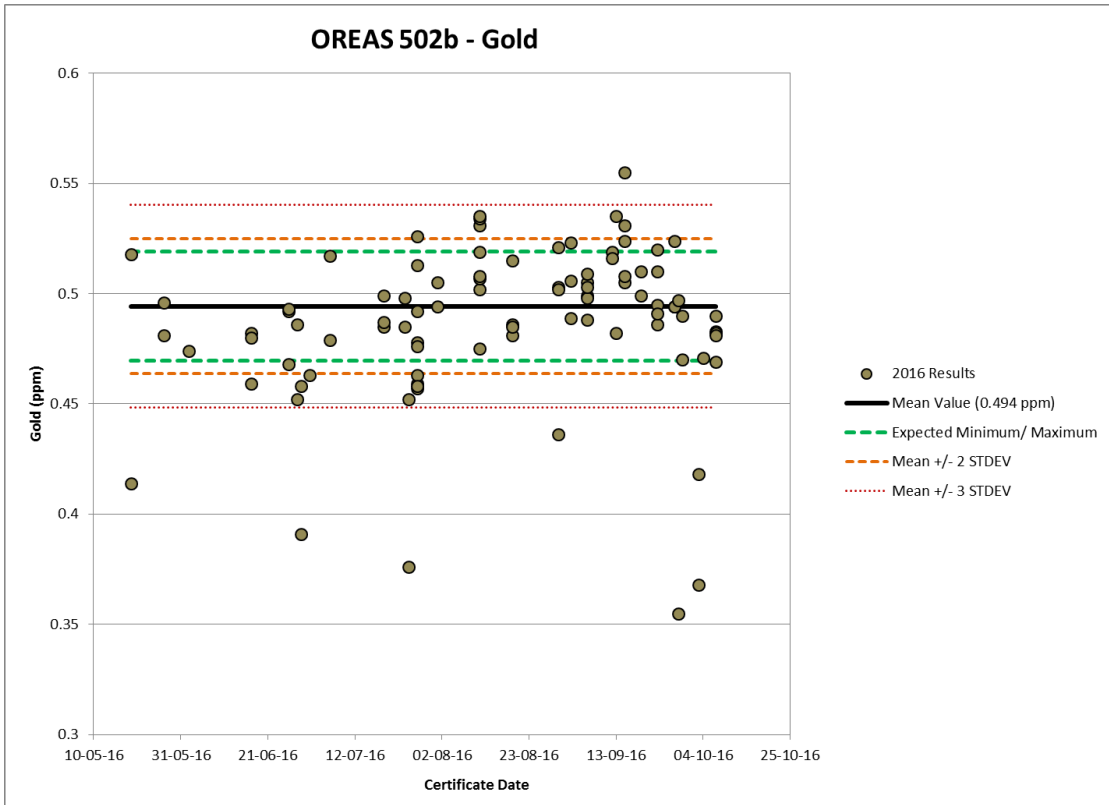
Source: SRK, 2016

**Figure 11-8: Molybdenum Results for OREAS 504b**



Source: SRK, 2016

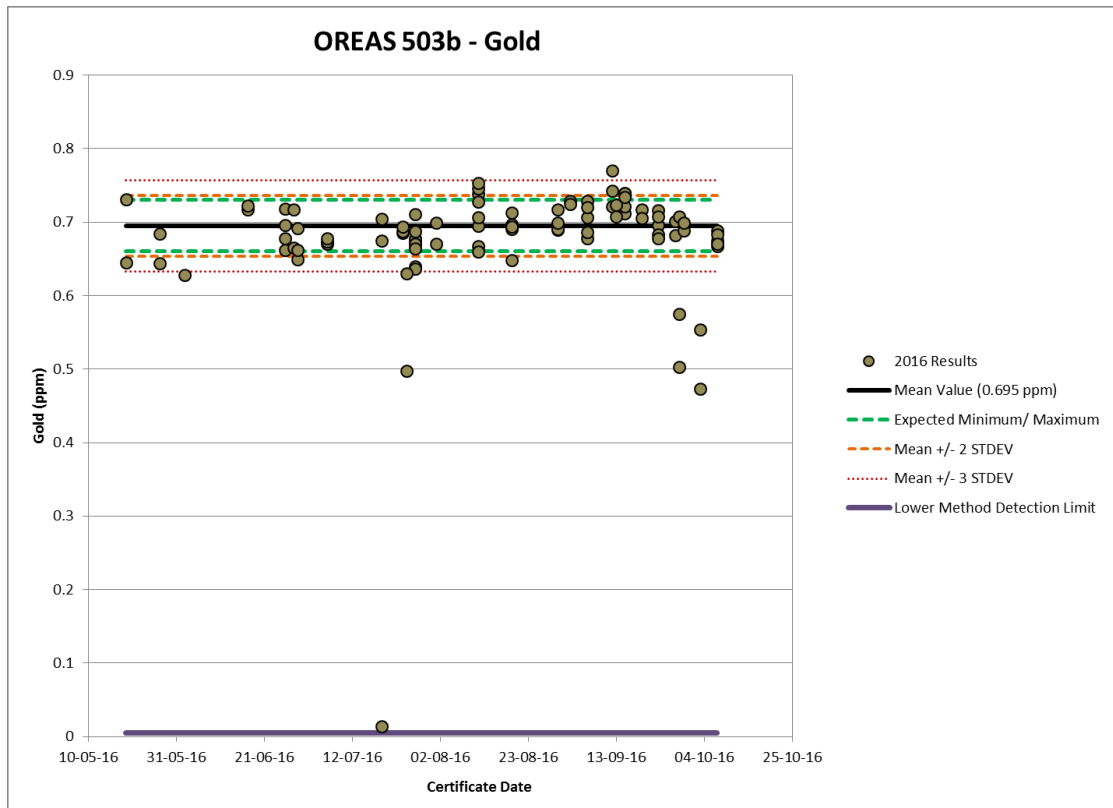
**Figure 11-9: Gold Results for OREAS 501b**



Source: SRK, 2016

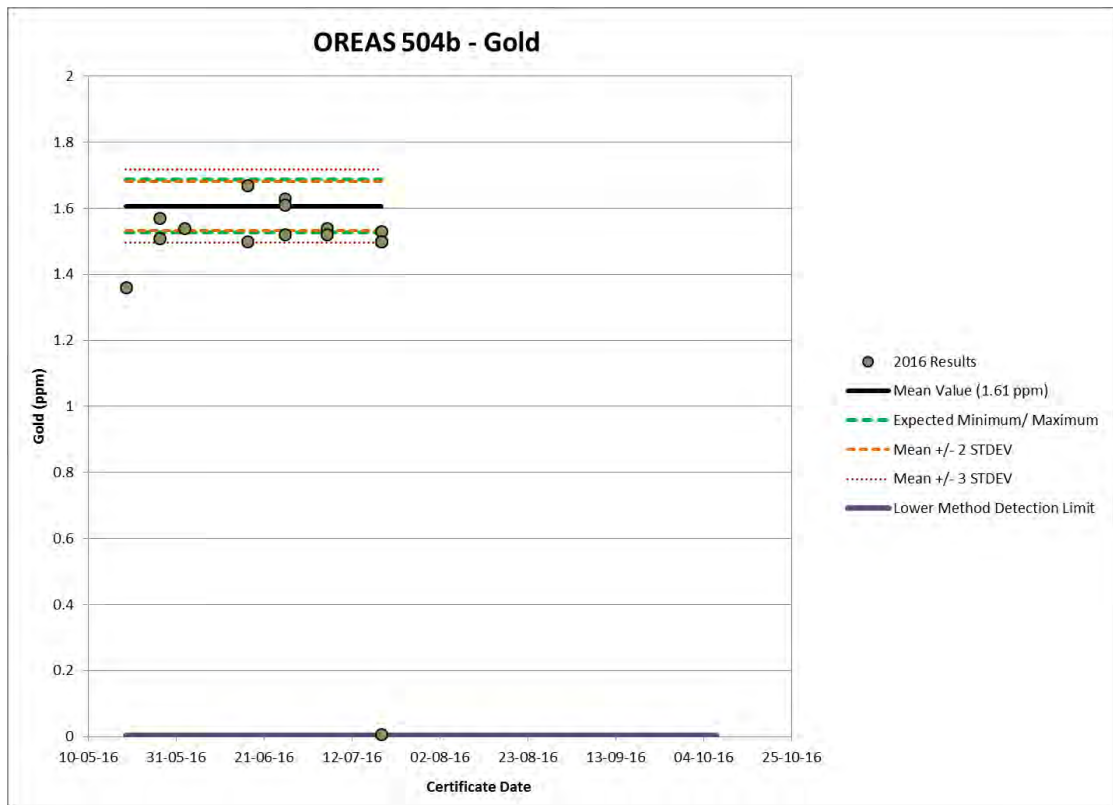
**Figure 11-10: Gold Results for OREAS 502b**





Source: SRK, 2016

**Figure 11-11: Gold Results for OREAS 503b**



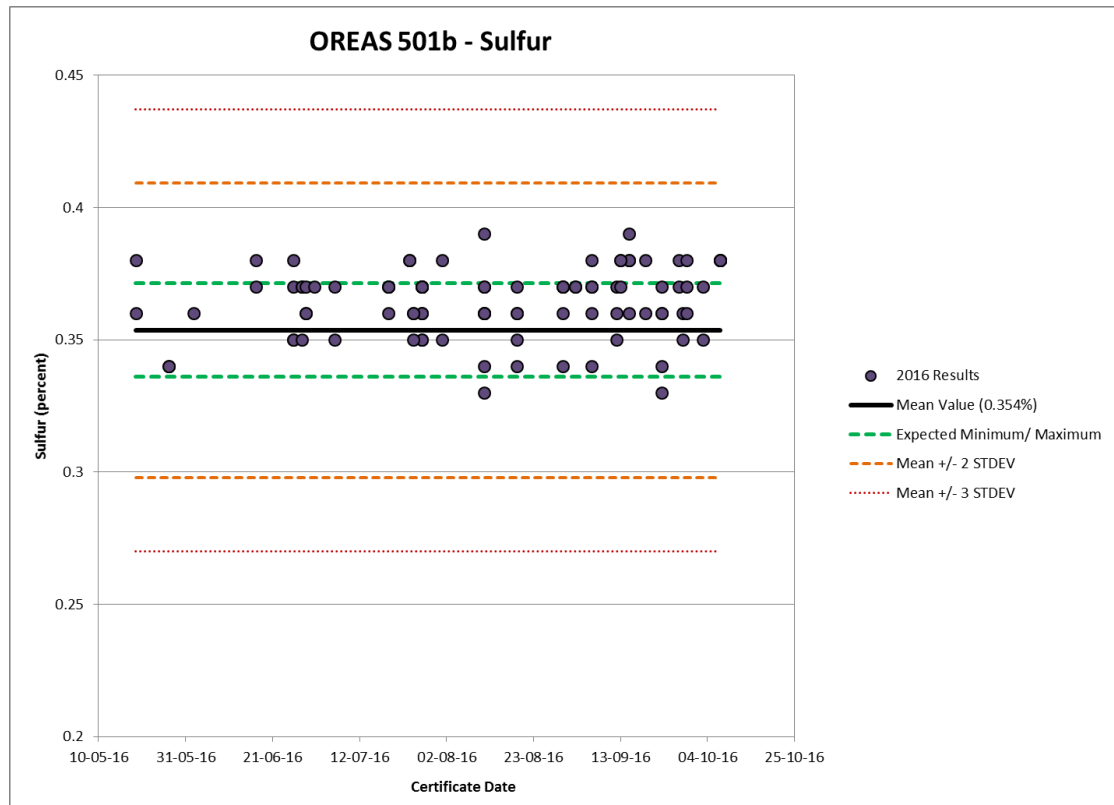
Source: SRK, 2016

**Figure 11-12: Gold Results for OREAS 504b**



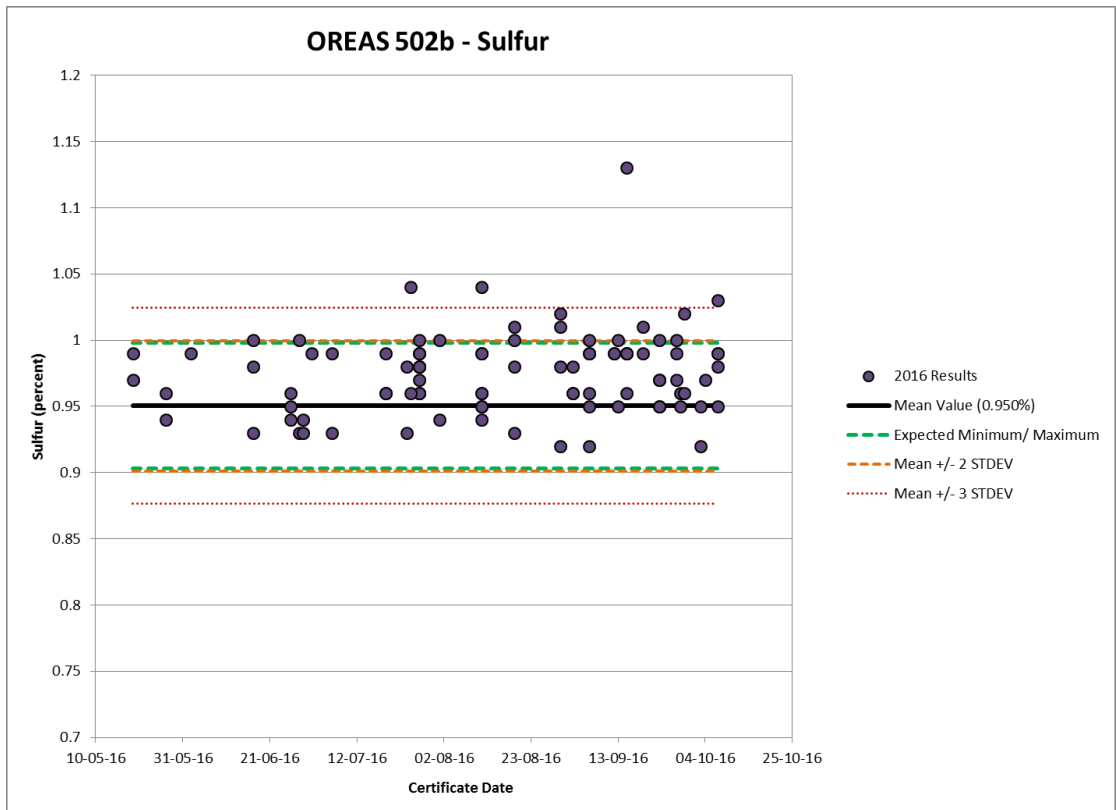
The main CRMs have reported average sulphur values in addition to the metals discussed above. Sulphur values are currently applied to define metallurgical material types, and although sulphur is not reported in the MRE, it is an important component of the oxide model.

Figure 11-13 to Figure 11-16 show the sulphur results for the four CRM sample groups. Generally, the CRM samples performed well with respect to total sulphur, with no apparent bias.



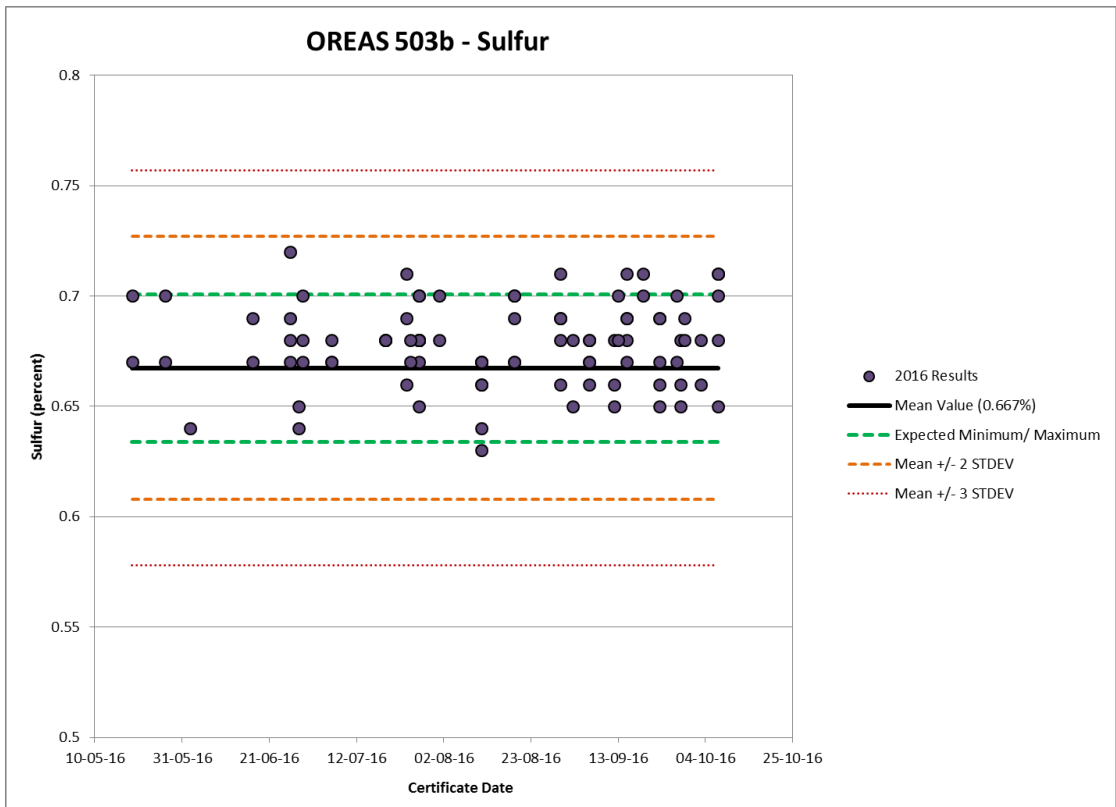
Source: SRK, 2016

**Figure 11-13: Sulphur Results for OREAS 501b**



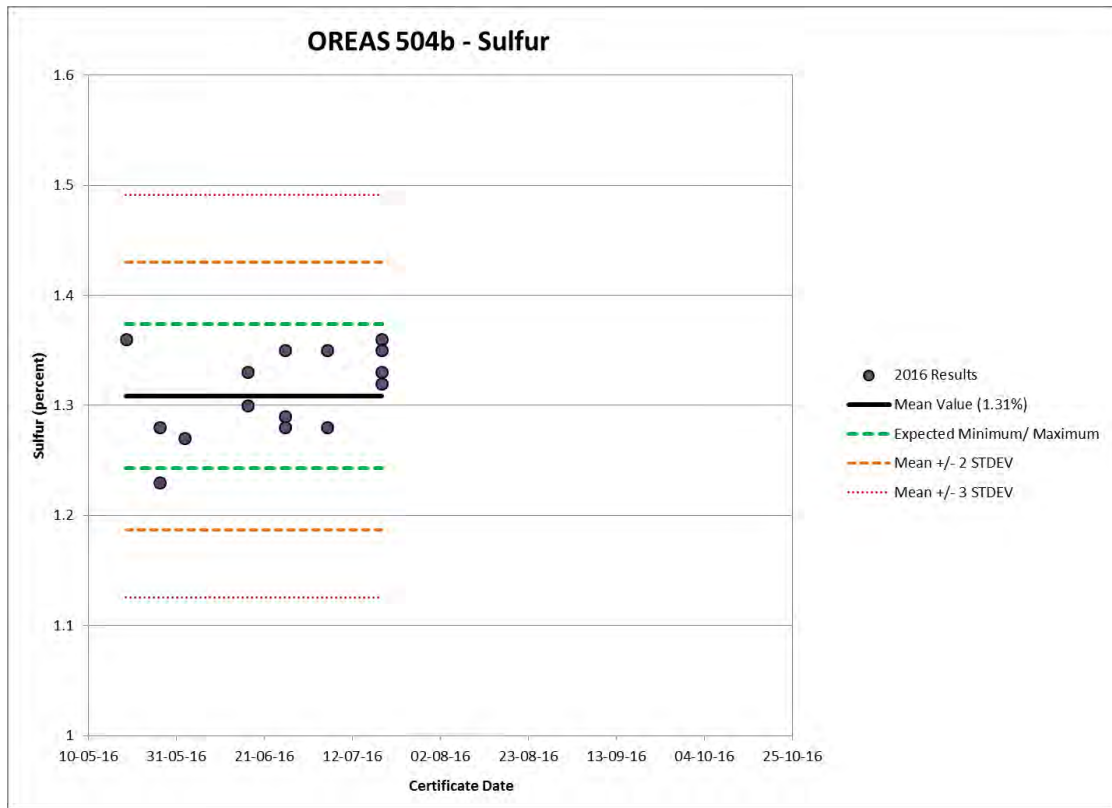
Source: SRK, 2016

**Figure 11-14: Sulphur Results for OREAS 502b**



Source: SRK, 2016

**Figure 11-15: Sulphur Results for OREAS 503b**



Source: SRK, 2016

**Figure 11-16: Sulphur Results for OREAS 504b**

### 11.4.2 Blank Samples

Era included samples of OREAS 27b, which is barren, coarse felsic volcanic reference material in the 2016 drill sample suite. The batch of samples for YD568 included four samples of OREAS 24b, which is coarse barren granodiorite. The certified values and lower method detection limits are listed in Table 11-3. This material is suitable for assessing the risk of cross-contamination or sample mix-ups at the laboratory, and the mean values are much lower than the economic values for each element of interest.

**Table 11-3: Certified Values and Method Detection Limits for Blank Samples**

CRM	Copper (ppm)	Molybdenum (ppm)	Gold (ppb)	Sulphur (%)
OREAS 24b	38.0	4.03	<3	0.198
OREAS 27	4.61	10.2	<1	0.007
<b>Lower MDL</b>	<b>2</b>	<b>1</b>	<b>5</b>	<b>0.010</b>

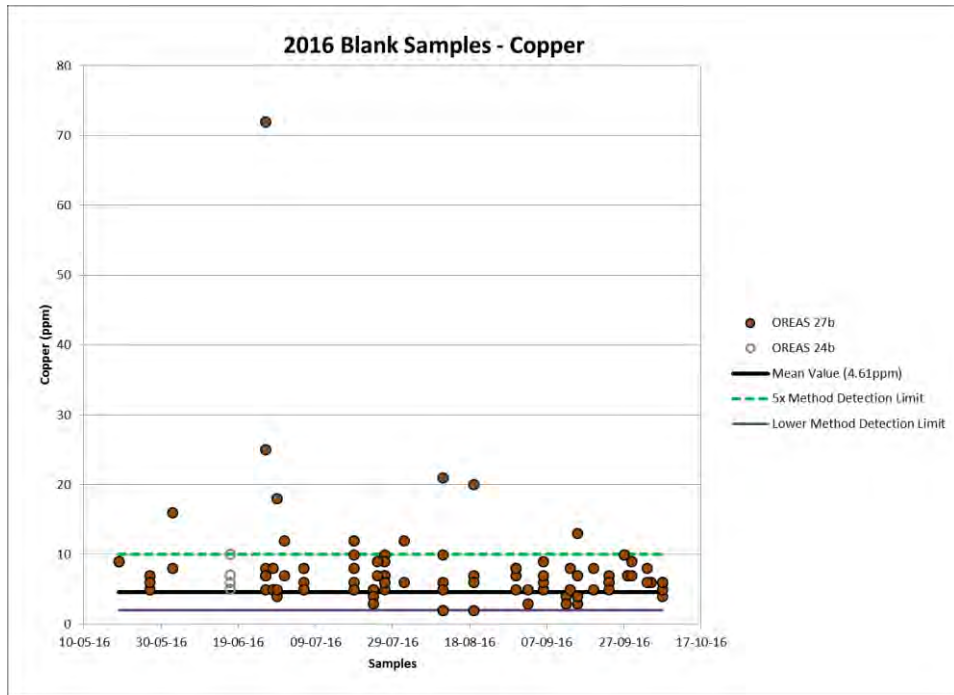
Source: SRK, 2016

Results for copper, molybdenum, gold and sulphur for the 99 blank samples are shown in Figure 11-17 to Figure 11-20. The average blank sample insertion rate is every 35 or 40 samples, and is adequate for analytical sample batches of 60 samples.

Results for copper are variable, and many are more than five times the method detection limit. Because the mean value is close to the method detection limit, the variability can be attributed to inherent analytical uncertainty.

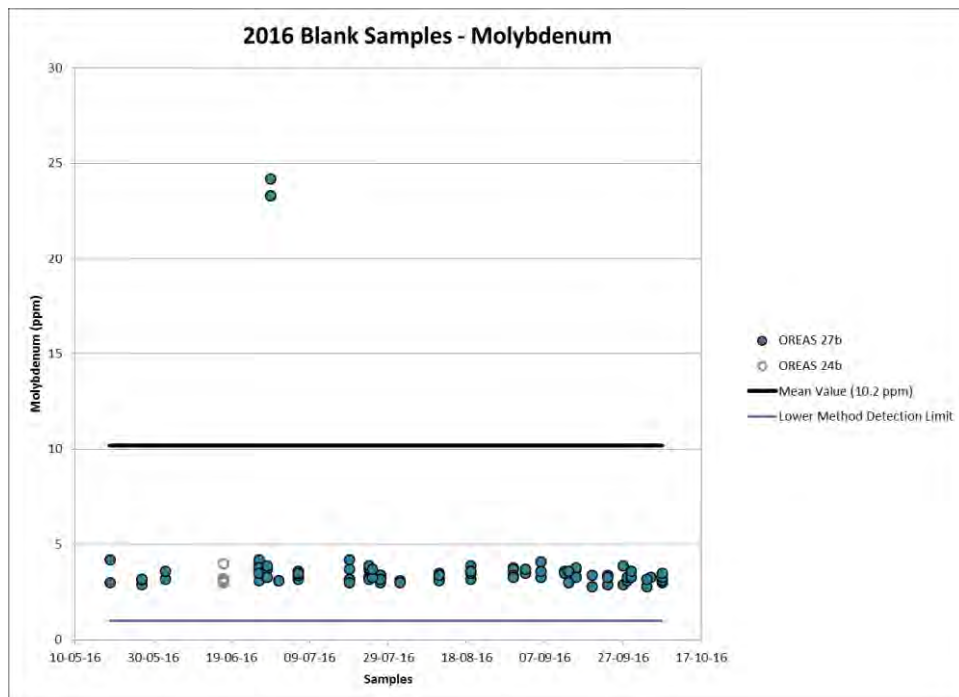


The variability may indicate cross-contamination during analysis. One of the values is so far from the mean that it could indicate a sample mix-up. Molybdenum and gold values are less variable and have values in the acceptable range. Measured sulphur values should be less than the lower method detection limit, and the observed variation is from analytical uncertainty in values near the detection limit.



Source: SRK, 2016

**Figure 11-17: Copper Results for Blank Samples**



Source: SRK, 2016

**Figure 11-18: Molybdenum Results for Blank Samples**





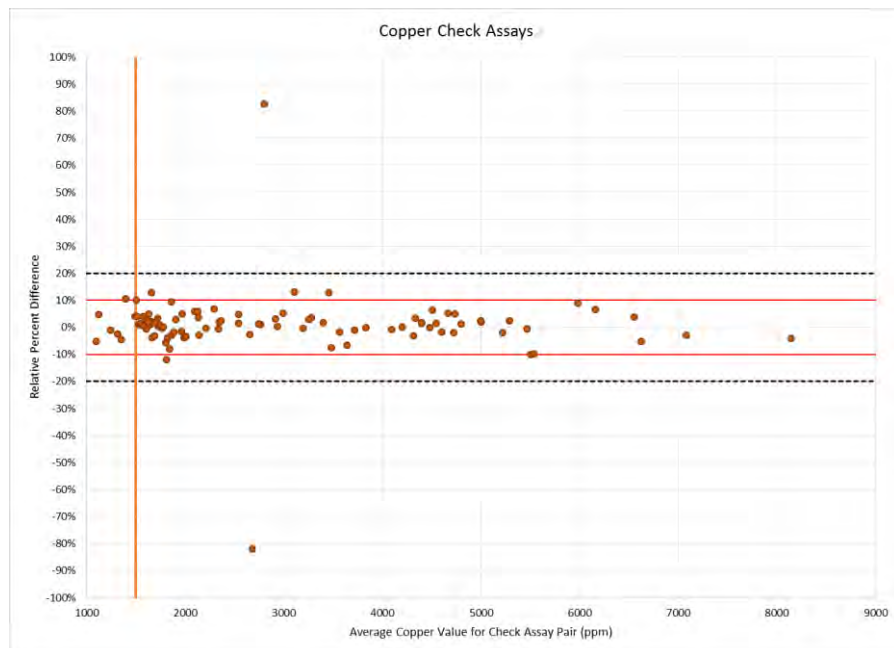
### 11.4.3 Check Assay Analysis

Australian Laboratory Services (ALS) in Brisbane, Australia, completed check assays on select pulp samples. For the 2016 drilling programme, 98 drillhole samples were sent in Batch 1 of check samples, about 3.3% of the total. There were also fourteen CRM and four blank samples in the first batch of check samples. The second batch of samples for check assay analysis was in progress while this Report was being written and results were not available. Figure 11-21 to Figure 11-23 show the Relative Percent Difference (RPD) vs. average value for copper, molybdenum and gold for the check assay pairs. The equation for RPD is:

$$RPD = (\text{Duplicate} - \text{Original}) / \text{Average}$$

The desired maximum difference for check assay results is within 10% of the original or average value. Only seven sample pairs varied by more than 10% for copper values. All the selected check assay samples are greater than 1,000-ppm copper; most are economic grades indicated by the vertical line on Figure 11-21 to Figure 11-23. The measured copper values are several orders of magnitude greater than the lower method detection limit, which provides data with low analytical uncertainty, evident in the consistent distribution of relative difference for all copper values. The two pairs of samples with high relative differences may be incorrectly reported; Era geologists were working with the laboratory to resolve this apparent discrepancy as this Report was in preparation.

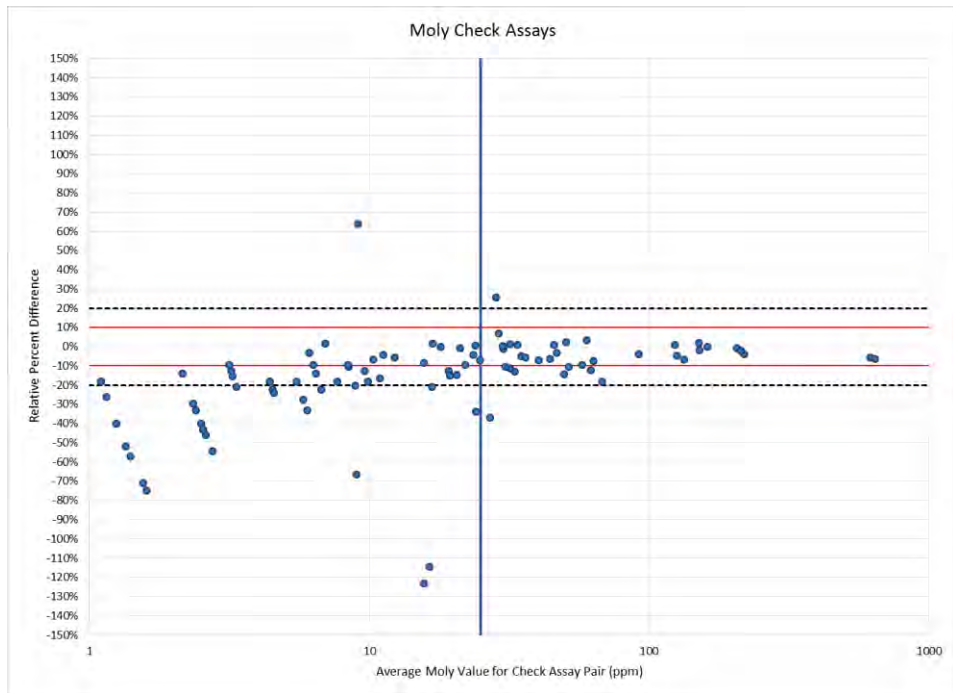
Molybdenum and gold values are much closer to the respective lower method detection limits, and the paired values have generally higher relative differences than copper values. The greater deviation in sample pairs for molybdenum and gold reflects lower concentrations of these metals and the increase in inherent analytical uncertainty as values approach the method detection limit. For values of economic interest, most check samples performed well relative to the original values, especially for copper. Molybdenum and gold results may have a low bias at the second laboratory but this trend is most evident at low concentrations and may be related to inherent analytical uncertainty.



Source: SRK, 2016

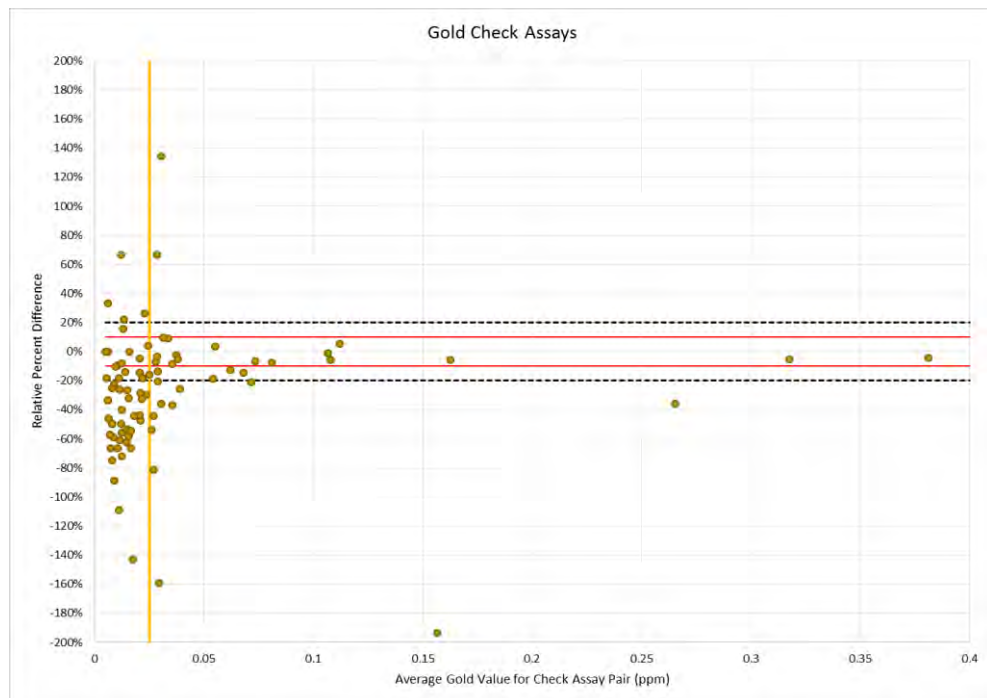
**Figure 11-21: Check Assay Relative Percent Difference vs. Average Value, Copper**





Source: SRK, 2016

**Figure 11-22: Check Assay Relative Percent Difference vs. Average Value, Molybdenum**



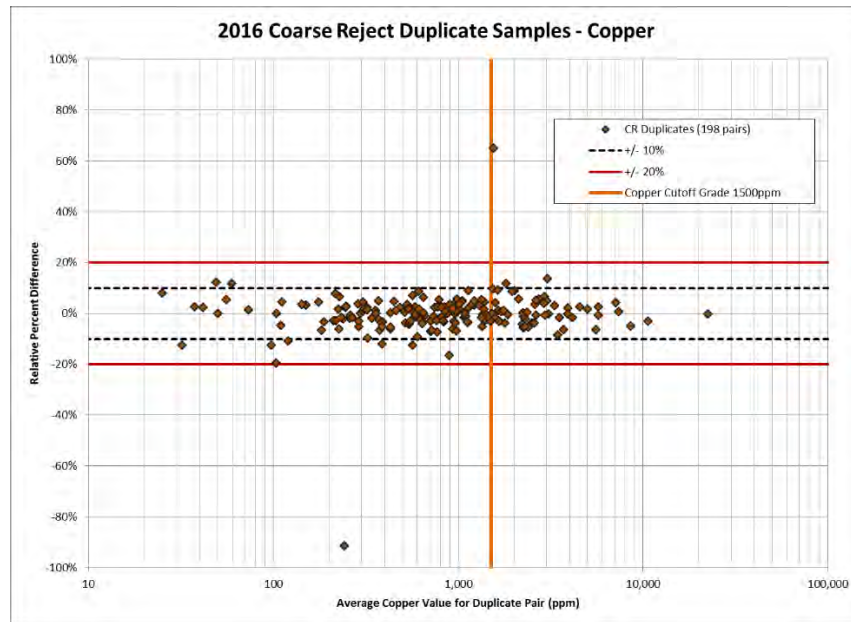
Source: SRK, 2016

**Figure 11-23: Check Assay Relative Percent Difference vs. Average Value, Gold**



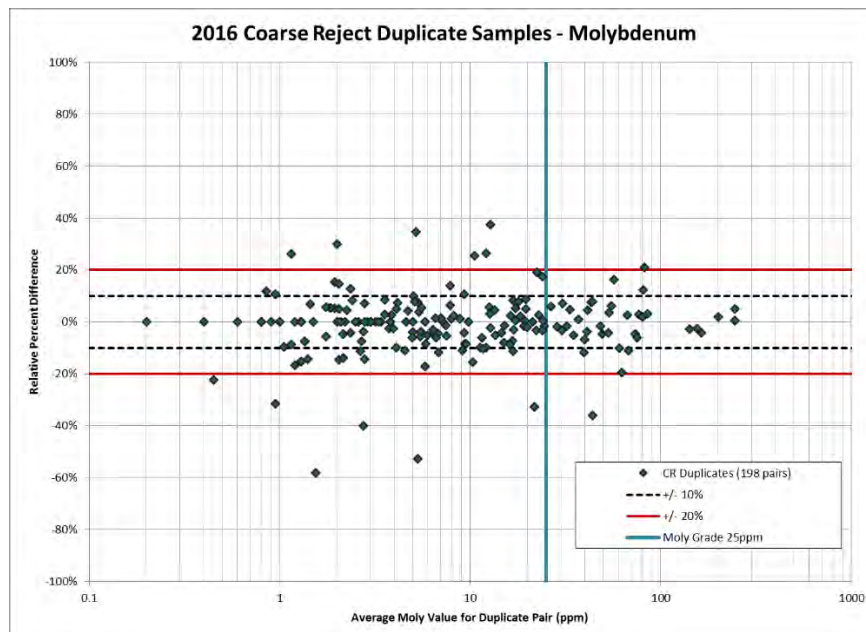
### 11.4.4 Coarse Reject Duplicate Sample Pairs

The 2016 drilling programme included two splits from 6.6% (198) of the drill samples. These splits were collected after the crushing phase of preparation to assess the homogeneity of the sample after crushing before the sample mass was reduced for pulverization. The analytical values of the original and duplicate sample pairs should be within 20% of each other for values greater than about five times the method detection limit. Results for copper, molybdenum, gold and sulphur are shown as charts of relative percent difference vs. average value, similar to the check assay results above, in Figure 11-24 through Figure 11-27.



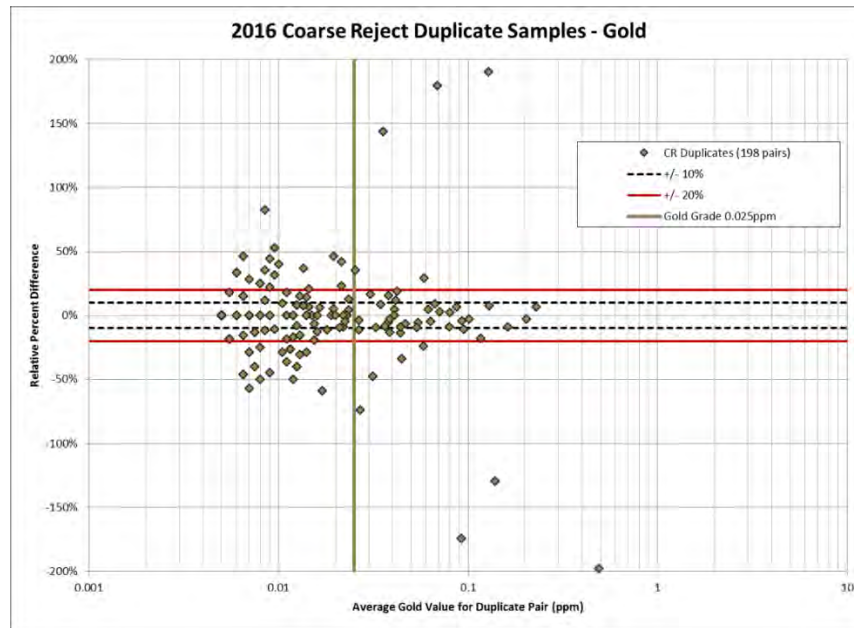
Source: SRK, 2016

**Figure 11-24: Coarse Reject Duplicates Relative Percent Difference, Moly**



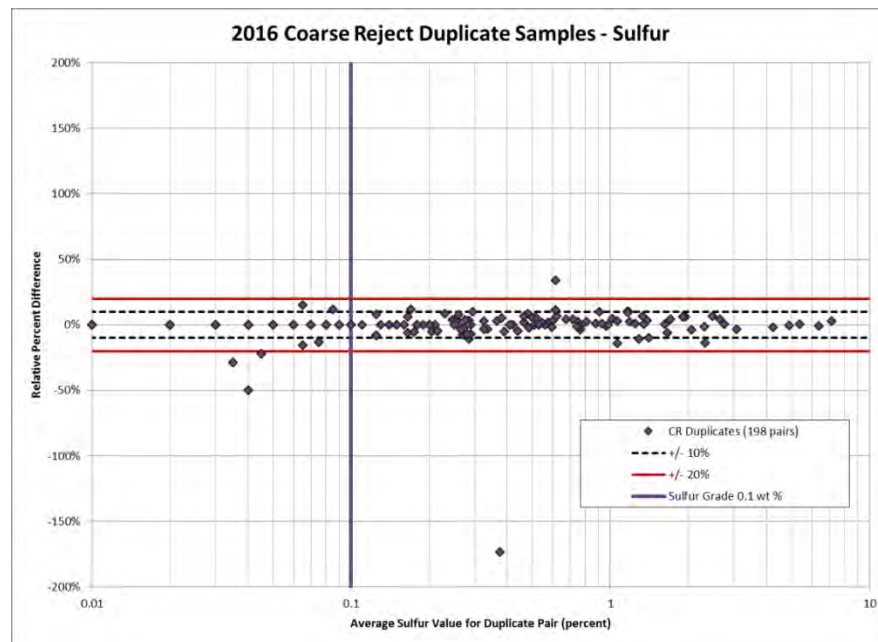
Source: SRK, 2016

**Figure 11-25: Coarse Reject Duplicates Relative Percent Difference, Moly**



Source: SRK, 2016

**Figure 11-26: Coarse Reject Duplicates Relative Percent Difference, Gold**



Source: SRK, 2016

**Figure 11-27: Coarse Reject Duplicates Relative Percent Difference, Sulphur**

### 11.4.5 Actions

Era should continue to use 4-acid digestion to completely dissolve the silicate host rock and get representative copper and molybdenum values. The current gold fire assay and multi-element analysis methods are suitable to determine base and precious metal abundances in the deposit. CRM sample results are the best indication of data quality, and Era should continue to monitor them as new results are received from the lab.



The insertion rate of CRM samples could be decreased, to a minimum of one per sample batch. Coarse blank samples add confidence to the analytical data to verify the quality of the preparation process. The new procedure to generate coarse reject duplicate samples also validates the current sample preparation protocols

#### **11.4.6 Results**

Era's assay QA/QC protocol for the 2016 drilling programme provides verification for all the sample preparation and analysis stages.

On average, each batch of fire assay samples should have one blank and one standard sample. There should also be enough CRM samples to include an average of two or three in each batch of ICP samples. The CRM results assess the laboratory's analytical capability at a range of grades representative of the deposit.

Era should continue to evaluate assay QA/QC data as results are received and include data review in the process of adding new analytical results to the resource database.

### **11.5 Opinion on Adequacy**

It is the author's opinion that the sample security at the Project is adequate to maintain Chain of Custody until the analytical samples are relinquished for shipment to the analytical laboratory. The quality of sample preparation and analytical procedures meets or exceeds current industry standards, and the resulting data is suitable to use in a Mineral Resource Estimation.



## 12 Data Verification

Yandera geologists produce drillhole logs on paper, which must be transcribed to digital data tables. These tables are then imported to the master database for modelling applications. Laboratory data is received from the laboratory in digital format and imported to the master database. To ensure accurate data is used for modelling, the digital database is compared to the sources, i.e., to the geological logs and assay certificates.

For drilling reported previously, data verification was completed for geology and analytical data on a portion of the drillholes. Although some drillholes from all phases were reviewed, emphasis was placed on verification of the 2016 drilling. For this Report, about 11% of the 2016 drillholes were selected for verification, as well as several holes verified for the 2015 resource report with data entry errors. Since the last resource estimation, logged geology has been re-interpreted and the master database updated.

### 12.1 Procedure

The author verified drillhole collar locations against a high-resolution topographic surface. Several holes that appeared much lower than current topography were reconciled, realizing that a number of drill sites required extensive earthwork for construction. The apparent discrepancies were from cut or fill from pad construction. Most of the drillholes with collar locations above topography do not have assay or lithology data, and are not material to the resource estimation. A second collar location survey was completed for recent drilling but results indicated incorrect X-Y locations for many drillholes. Original collar survey results were more consistent and were maintained in the database. Downhole survey results appeared reasonable when displayed in 3D modelling software. Several drillholes with unusual trajectory were verified and match the source data. A summary of geological and analytical data verification follows.

For Era's 2016 resource drilling campaign, holes YD564 through YD605, 5 holes (11%) were selected to compare the electronic geological database and original drill logs. This group of drillholes was completed after the previous resource estimation in 2015, and over half of them were drilled in the Dimbi deposit area. Verified drillholes are located in the four main deposit areas tested in 2016. Verification results for the 2016 programme are summarized in Table 12-1. Digital copies of all analytical laboratory certificates were available, and the gold, copper and molybdenum values in the database matched the certificates for all drillholes. Intervals in the digital tables for lithology, alteration and oxide zonation all matched the source logs except for one typographical error noted for alteration intervals in YD584. The 2016 drillholes comprise about 7% of the database and the group verified did not include the geotechnical holes drilled later in 2016.

Era drilling completed prior to 2016 was included in a previous resource estimation, which also required data verification. Because this data had been previously verified and reported, a subset of seven drillholes with errors identified in the previous report was selected for verification. Table 12-2 summarizes the results. Historical drilling completed by Kennecott and BHP was also included in previous resource estimations, and one of these drillholes was selected for verification. Historical drillholes completed before Era (n = 104) comprise 18% of the drillholes in the database.



All copper, molybdenum and gold values in the database for the pre-2016 drillholes verified match the values on the assay certificates. Since the last resource report, Era has corrected the assay database, and these changes are evident in YD258 and YD457, which had incorrect copper, gold and molybdenum values in 2015. The other drillholes re-verified in 2016 had correct values in 2015 and have not changed. Geological logging in these holes has generally not been updated since 2015, and discrepancies between the drillhole logs and database tables still exist. The drillhole geology does not directly affect the geological model, which is built on a framework of interpreted lithology from cross sections.

**Table 12-1: Summary of 2016 Drillhole Data Verification**

Hole ID	Deposit	Year Drilled	Purpose	Lithology	Alteration	Oxidation	Copper	Moly	Gold
YD577	South Dimbi	2016	Resource	Correct	Correct	Correct	Correct	Correct	Correct
YD578	Dengru	2016	Resource	Correct	Correct	Correct	Correct	Correct	Correct
YD584	Omora	2016	Resource	Correct	Incorrect	Correct	Correct	Correct	Correct
YD596	Dimbi	2016	Resource	Correct	Correct	Correct	Correct	Correct	Correct
YD597	Imbruminda	2016	Resource	Correct	Correct	Correct	Correct	Correct	Correct

Source: SRK, 2016

**Table 12-2: Summary of Verification, Pre-2016 Drillholes**

Hole ID	Deposit	Year Drilled	Purpose	Lithology	Alteration	Oxidation	Copper	Moly	Gold
YD556	Dimbi	2013	Exploration	Correct	Correct	Correct	Correct	Correct	Correct
YD546	Imbruminda	2012	Resource	Incorrect	Incorrect	Correct	Correct	Correct	Correct
YD525	Gremi	2012	Resource	Correct	Correct	Incorrect	Correct	Correct	Correct
YD457	Omora	2011	Resource	Incorrect	Incorrect	Correct	Correct	Correct	Correct
YD258	Imbruminda	2010	Resource	Incorrect	Incorrect	Incorrect	Correct	Correct	Correct
YD208	Imbruminda	2008	Resource	Incorrect	Incorrect	Incorrect	Correct	Correct	Correct
DDH066	Imbruminda	1975	Exploration	Correct	Correct	Correct	Correct	Correct	Correct

Source: SRK, 2016

## 12.2 Limitations

Geological logs and assay certificates were available for all drillholes verified. Criteria for logging lithology and alteration were not consistent for all drilling campaigns, and the resulting database is not entirely consistent. During detailed geological interpretation for resource modelling, the Project team found many discrepancies between lithology and alteration in neighbouring drillholes. This was largely due to different interpretations by logging geologists over time, and evolution of the working model.



Because some geological data in the database was inconsistent, it was not applied directly to the geological model. Instead, during this 2016 modelling effort, Era geologists revisited core photography and reconciled previous discrepancies to build cross sectional interpretations. These revised cross sections were used to underpin the geologic model.

### **12.3 Opinion and Data Adequacy**

All verified analytical values for economic metals match the assay certificates and are suitable for use in resource modelling. Following corrections and exclusions in the geologic data set, it is the author's opinion that the Yandera dataset is suitable for modelling and resource estimation.





## 13 Mineral Processing and Metallurgical Testing

### 13.1 The Nature and Extent of the Testing and Analytical Procedures

#### 13.1.1 Comminution Studies

##### 13.1.1.1 Preliminary Comminution Studies – AMDEL 2007

Preliminary comminution studies conducted at AMDEL (2007) focused primarily on composite samples obtained from the hypogene zone, oxide and mixed zones. Bond Ball Work Indices (BBWi) were conducted on a high-grade and low-grade hypogene sample as well as an oxide and mixed sample.

The results of this study were that the samples tested reported to the medium to hard category, with BBWi results ranging from 15.4kWh/t to 18.4kWh/t.

##### 13.1.1.2 Main Comminution Study – AMMTEC 2008

In 2009, a more extensive comminution study programme was executed at AMMTEC under the supervision of GRD Minproc. A data set of 61 samples of the hypogene ore was used to execute comminution test work. A series of drill cores was submitted for test work purposes, with emphasis on ore type and location. The samples were derived from 11 drill cores from the Gremi, Omora and Imbruminda deposits. The 61 samples were derived from various depths along the 11 cores, so that variability in terms of depth could be assessed. It should be noted that the focus of this work was the sulphide zones only.

The comminution results are presented in Table 13-1.

**Table 13-1: Summary of Comminution Results (AMMTEC 2008)**

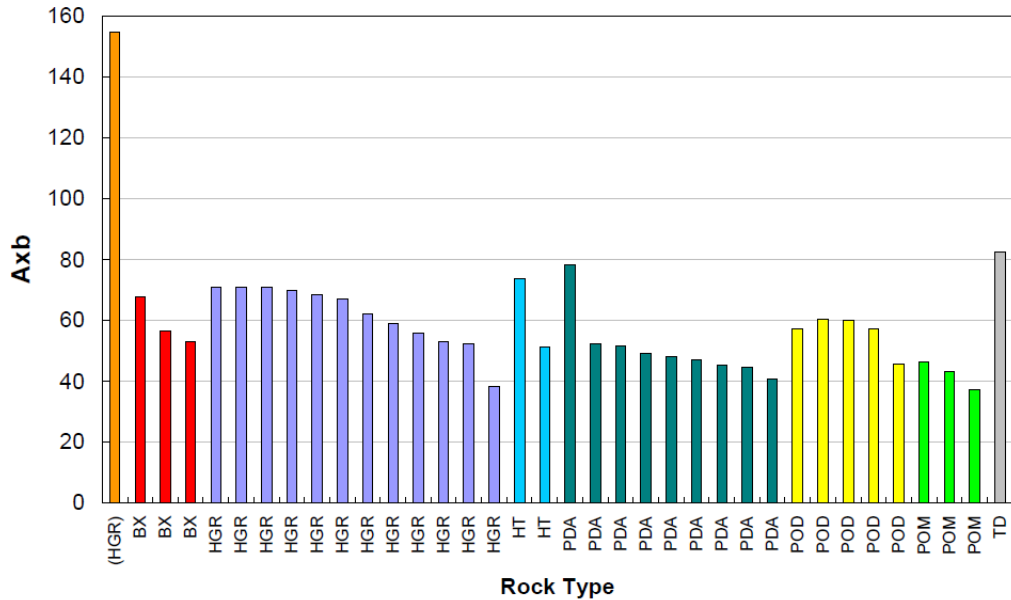
Item	Bond Ball Work Index	Bond Rod Work Index	Bond Crusher Work Index	Abrasion index	Dropweight Index	Axb
Unit	kWh/t	kWh/t	kWh/t	-	kWh/m <sup>3</sup>	-
Maximum	19.2	17.3	7.7	0.30	7.5	119
80th percentile	17.2	15.8	7.6	0.17	5.5	46
Average	15.1	13.8	7.3	0.10	4.7	56
Minimum	8.0	12.6	6.4	0.03	2.0	37

The results obtained from this study were consistent with previous studies executed and indicated that the hypogene ore from the Omora, Gremi and Imbruminda deposits were of medium to high hardness, based on the Bond Work Indices presented, and a moderate to medium competency in terms of Axb values. In addition to this, the samples tested had a low abrasion character and therefore excessive crusher liner wear is not anticipated for these samples.

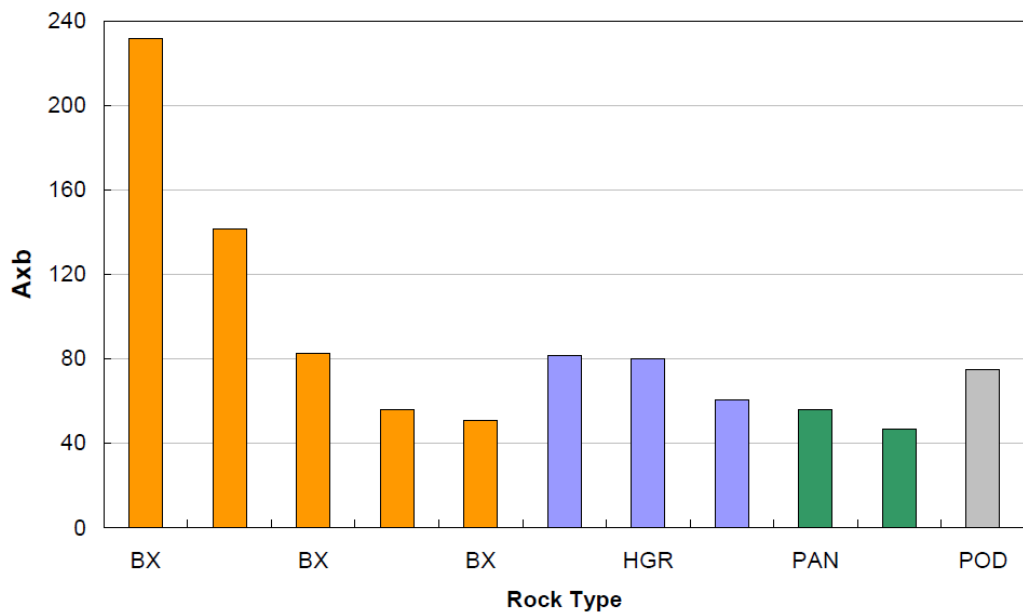
The similarity in Bond Ball Work and Bond Rod Work Indices indicates amenability to an SAB (C) circuit, with a Semi Autogenous Grinding (SAG) mill specific energy of approximately 6 to 7kWh/t of feed for larger throughputs.



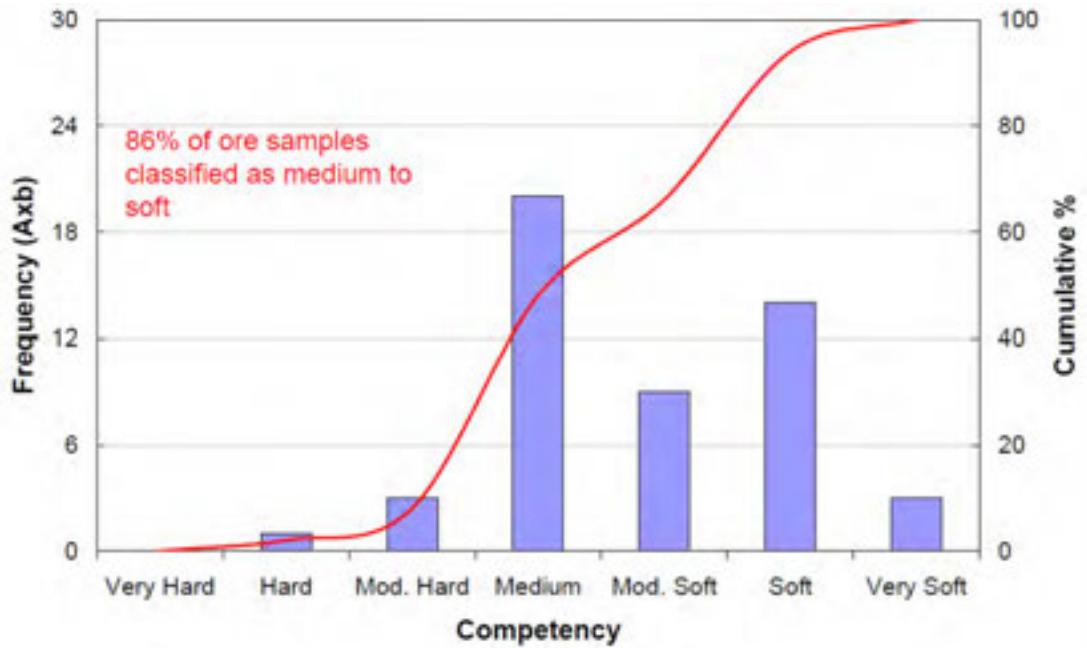
Variability in ore competency as a function of lithology is presented for Gremi and Omora samples in Figure 13-1 and Figure 13-2 respectively. Approximately 86% of samples tested were classified as medium to soft, as shown in Figure 13-3.



**Figure 13-1: Variability in Ore Competency (Axb) for Samples derived from Gremi**

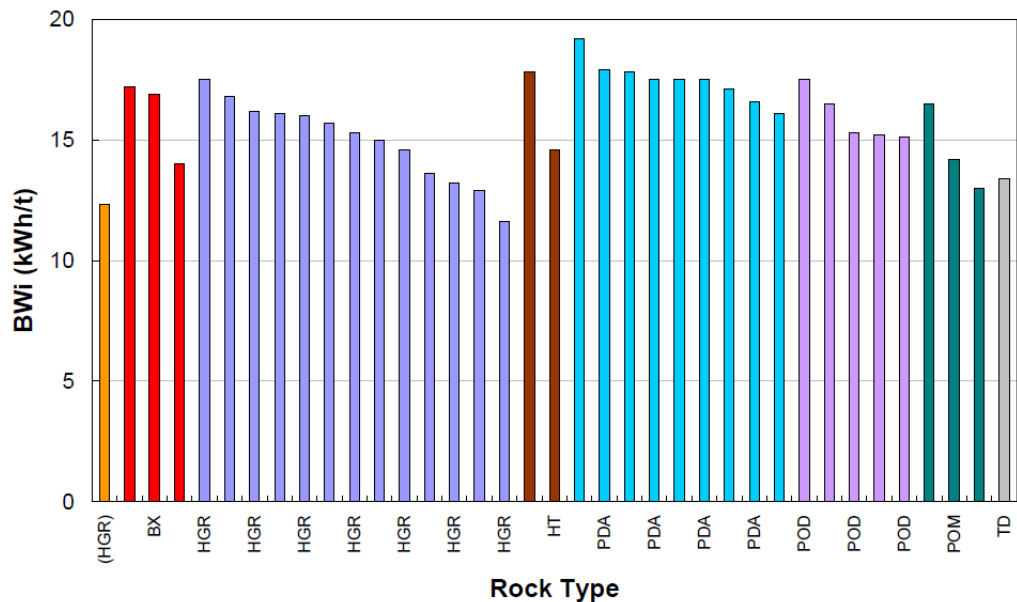


**Figure 13-2: Variability in Ore Competency (Axb) for Samples derived from Omora**



**Figure 13-3: Frequency Plot – Ore Competency**

Variability in the BBWi as a function of lithology is presented for Gremi and Omora samples in Figure 13-4 and Figure 13-5 respectively. Approximately 84% of samples tested were within the medium to hard range (13 to 18kWh/t), as presented in Figure 13-6.



**Figure 13-4: Variability in Bond Ball Work Index for Samples derived from Gremi**

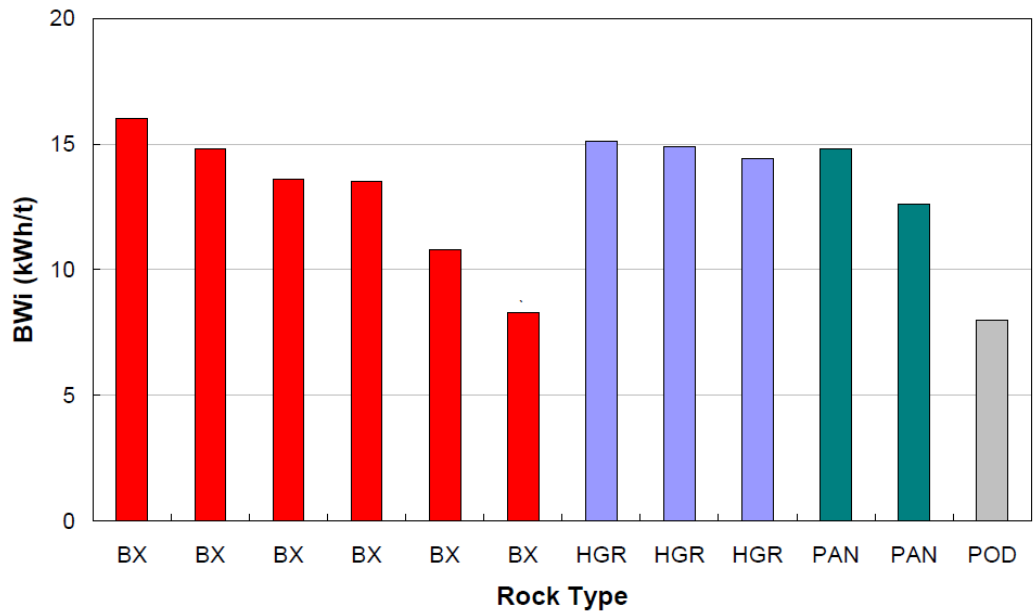


Figure 13-5: Variability in Bond Ball Work Index Samples derived from Omora

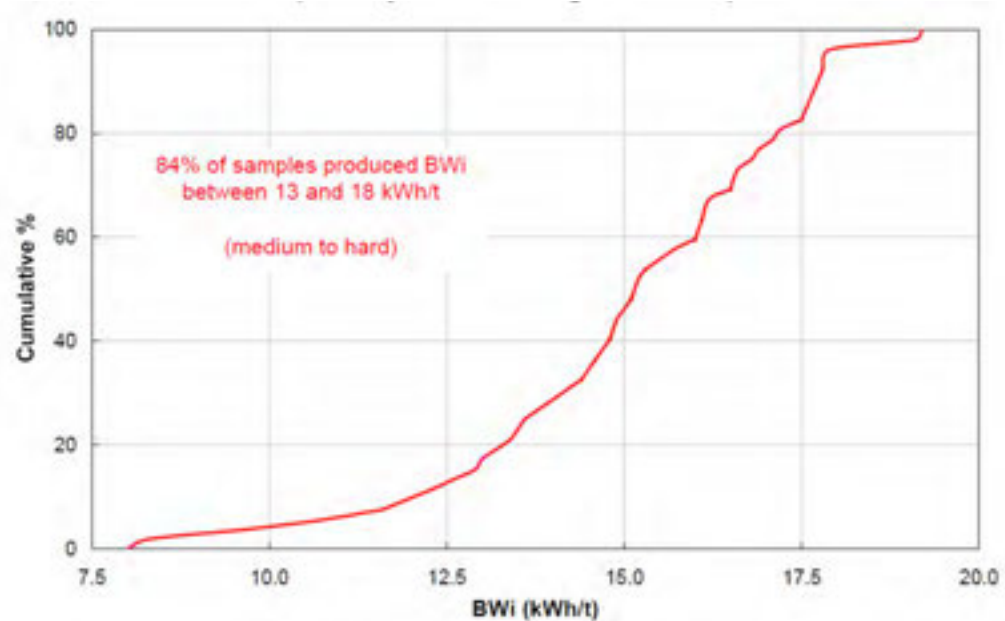


Figure 13-6: Frequency Plot – Bond Ball Work Index

### 13.1.1.3 Confirmatory Test Work on a Gremi Adit Sample

The following results were obtained from confirmatory test work on a sample derived from an Adit at the Gremi Site:-

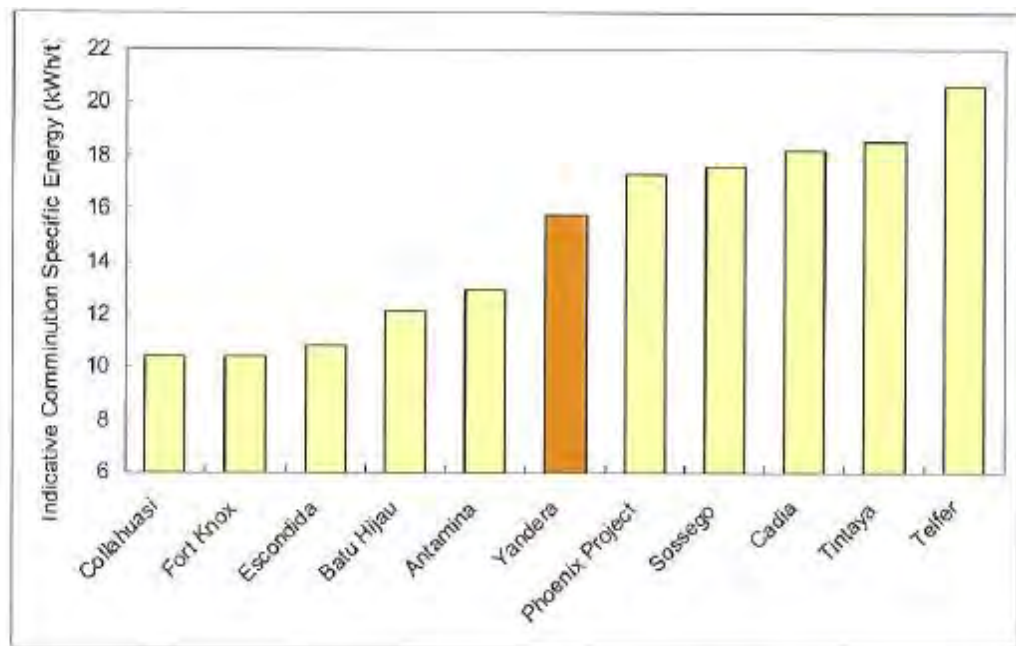
- The sample produced work indices within the same range as samples previously tested (13.4kWh/t and 11.7kWh/t) for Bond Ball Work and Bond Rod Work Indices respectively.
- A Bond Abrasion index of 0.142 was observed.



- SMC testing of the samples produced an Axb value of 63.9 and a drop weight index of 4.07kWh/m<sup>3</sup>.
- Uniaxial Compressive Strength (UCS) test work results ranged from 31.2 to 106.0.

### 13.1.1.4 Benchmarking of Comminution Results

As part of initial comminution test work, GRD Minproc benchmarked the indicative comminution specific energy of the ore associated with the Project to similar low-grade Cu porphyry projects. This ranking is presented in Figure 13-7.



**Figure 13-7: The Indicative Comminution Specific Energy Requirements of the Yandera Project in Relation to Similar Low-grade Cu Porphyry Projects**

### 13.1.1.5 Comminution Data Interpretation for Comminution Circuit Design

Orway Mineral Consultants (OMC), using the power modelling methodology, conducted interpretation of test work data for use in comminution circuit design. In this method, all comminution data received were used to establish the SAG, ball and total mill specific energy requirements to meet the target grind. The 70<sup>th</sup> and 80<sup>th</sup> percentile specific energy values were determined, and these were used in a number of iterations to establish the most appropriate comminution circuit, as well as equipment sizing.

It is recommended for the Definitive Feasibility Study (DFS) phase that this methodology be used in a manner, which maps the variability in mill specific energy of the LoM, and predicts how the specific energy requirements change with the mining plan. This will provide a holistic basis for mill circuit design.



## 13.1.2 Flowsheet Development Test Work

### 13.1.2.1 Background

In 2009, GRD Minproc executed a test work campaign with ALS AMMTEC, focused on the recovery of Cu from the Gremi and Omora deposits via flotation. These test work campaigns were focused on developing and optimizing flotation conditions for recovery of Cu minerals. The basis for this work was derived from similar operations such as Cadia and Telfer. This study was coupled with a number of mini-studies to establish the viability of producing several by-products. These studies had the following outcomes:

- Mo recovery via multiple stage cleaner flotation was established to be viable, and it has been demonstrated that Mo can be separated from a bulk rougher concentrate with relative ease.
- The potential to recover a saleable magnetite concentrate from flotation tailings via magnetic separation was investigated, and it was proven that a final concentrate grade of ~68% Fe and <4.5% SiO<sub>2</sub> could be produced, but that this required regrinding of the rougher magnetic separation concentrate to 80% passing 34 µm. Economic evaluation of this option indicated that this would not be financially viable.
- The potential to recover titanium- and phosphorus-bearing minerals from the rougher flotation tails via flotation were largely unsuccessful.

The recovery of Mo is the only option which is discussed in detail in this Report as this was the only option which was viable.

Test work was conducted on master composites of various lithologies from Omora and Gremi.

In late 2011, amore extensive campaign was initiated, which included additional composites from Gremi and Omora as well as the Imbruminda deposit. This campaign was conducted at ALS AMMTEC.

This work expanded on work conducted in 2009 and incorporated an investigation into the processing of the transitional (mixed ore) material in conjunction with the sulphide ore. Preliminary investigation into the processing of the oxide ore was also undertaken. This test work campaign was referred to as the “C-series test campaign” as master composites referred to as C1-C8 were produced for the various aspects of the test work.

This test work programme culminated in the completion of several locked cycle tests, including on LoM composites and on individual master composites of the various target zones. This allowed for production of bulk concentrates for vendor test work.

A test work programme was executed by BGRIMM in conjunction with this campaign on the same sample set.

In 2017, a test work campaign was executed with the intention of confirming that the defined sulphide process flowsheet would be applicable to a master composite of material from the Dimbi area. In addition to this, further test work was executed on a transitional and oxide ore from the Gremi area.

This section provides a summary of the relevant test work conducted to date.





## 13.1.2.2 Flotation Test Work on Sulphide Ores

### 13.1.2.2.1 Preliminary Scoping Studies (Up to and Including 2009)

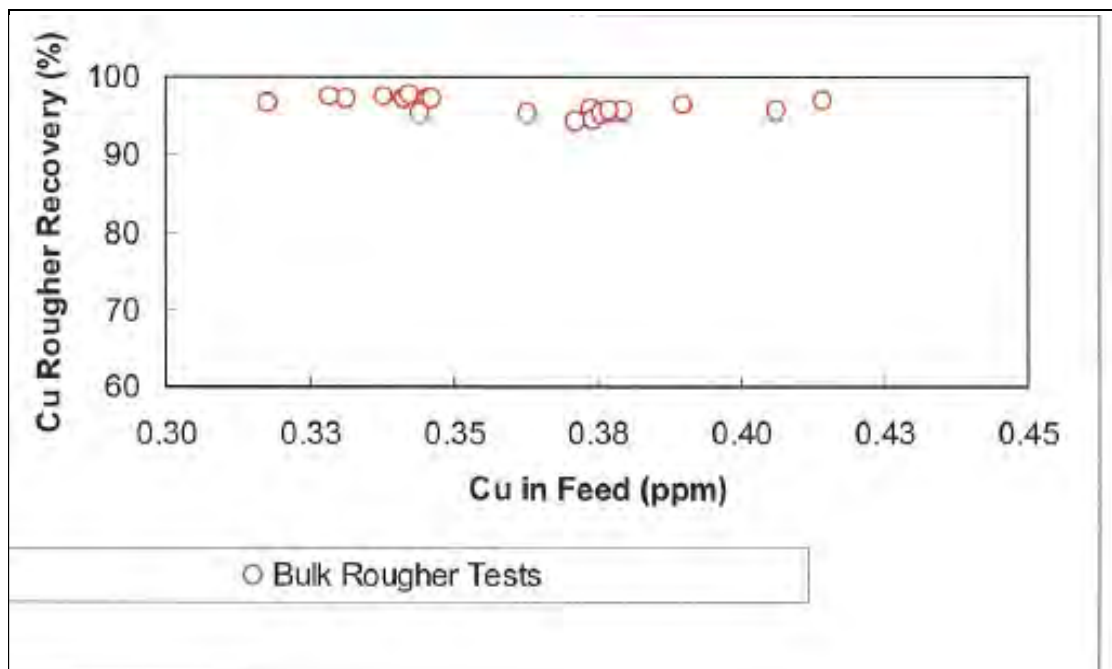
#### 13.1.2.2.1.1 Rougher Flotation Optimization Studies

In the 2009 test work campaign, an investigation was conducted to establish the flotation kinetic profiles and effect of grind on Cu recovery. This was initially investigated using two high-grade samples from Gremi (POD and HGR). This preliminary work demonstrated the insensitive nature of the Cu recoveries to grind size and the fast-floating nature of the ore. In addition to this, it was observed that Cu rougher recoveries in excess of 95% could be attained at relatively coarse grinds (80% passing 150  $\mu\text{m}$ ).

Further grind/recovery test work was conducted on seven composites derived from the Gremi and Omora areas. These samples were selected based on head grade and produced a series of grade recovery data for head grades ranging from 0.30% to 0.40% for Cu and 11ppm to 570ppm for Mo.

It was demonstrated that:

- Cu recovery was insensitive to head grade (refer to Figure 13-8).
- No significant decrease in Cu recoveries were noted between a grind size of 80  $\mu\text{m}$  passing 150  $\mu\text{m}$  and 80% passing 212  $\mu\text{m}$  (refer to Figure 13-9).
- Mo recovery and Au recovery were more significantly impacted at coarser grinds, as demonstrated in Figure 13-10.



**Figure 13-8: Effect of Cu Head Grade on Cu Recovery (Gremi and Omora)**

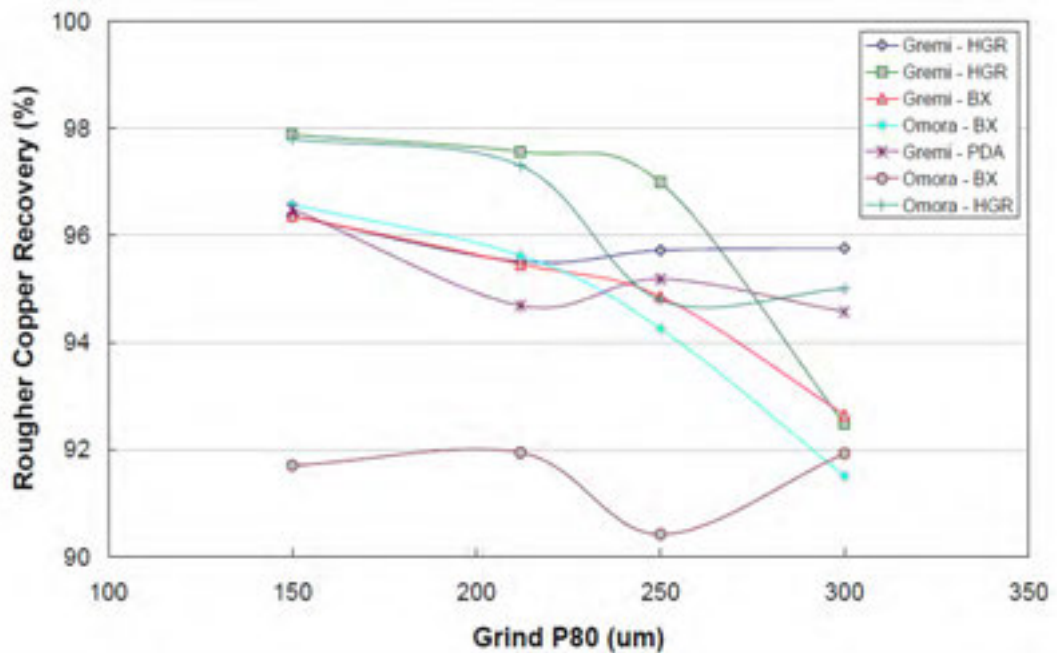


Figure 13-9: Effect of Grind on Cu Recovery (Gremi and Omora Samples)

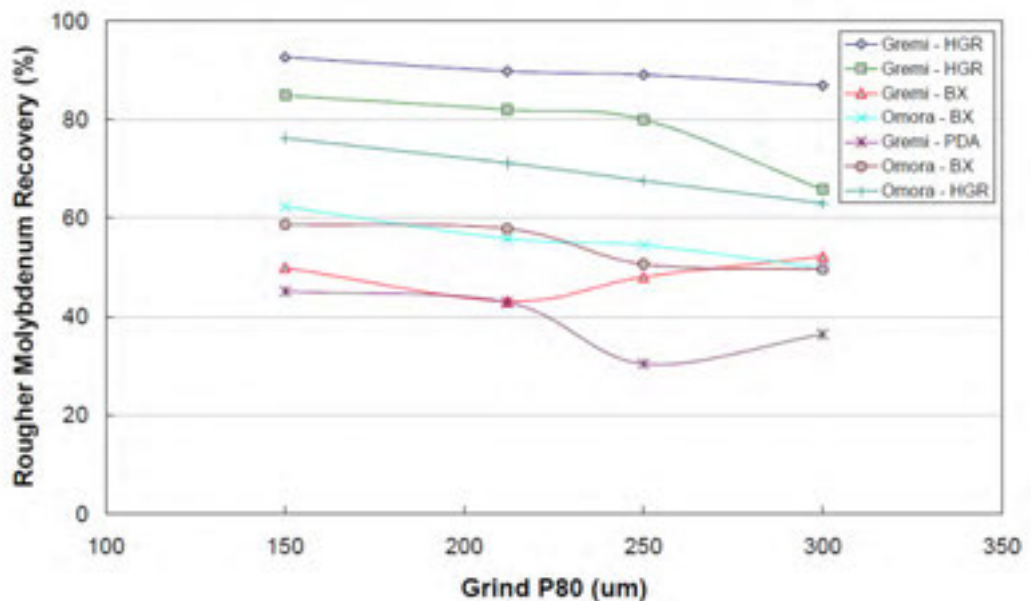


Figure 13-10: Effect of Grind on Mo Recovery

The grade/recovery data derived from the seven composite samples was used to establish the financial implications of the various grind sizes. It was established that a grind size of 150  $\mu\text{m}$  would be the optimal grind, based on Net Present Value (NPV). This grind was adopted for further test work.

Following the establishment of the optimum grind size for flotation (2009), six additional composites (three from Gremi, three from Omora). Emphasis was placed on Cu, S and Fe grades, and a sample set with varying pyrite content based on Cu: S ratio was produced.



The objectives of the test work campaign were as follows:

- Determine effect of collector addition location on recovery and grade.
- Determine optimum flotation feed density for rougher flotation.
- Establish most appropriate reagent suite and strategy for pyrite depression.

The salient points of the investigation were as follows:

- The addition of PAX during or after milling had no significant influence on rougher recoveries.
- A feed solids content of 32.5% solids by mass was the most appropriate for this ore, as higher feed densities resulted in higher mass pulls to concentrate, and reduction in kinetic rates of revenue elements.
- Pyrite depression via pH adjustment was noticeable only at high pH values (in excess of pH 12).

The baseline rougher conditions were set at 32.5% solids, at natural pH and at a grind of 80 % passing 150 µm. A series of tests were executed to establish if improved selectivity could be obtained by means of alternative copper collector use. In this series of tests, four different reagents were compared to the performance of PAX and SIPX. Two of the six composites were identified for this series of tests as these represented samples of “high” and “low” pyrite content.

The outcomes of this series of tests were that the use of highly Cu-selective reagents on the “high ” pyrite content ore resulted in significant reduction in mass pulls to concentrate as well as Fe and S recoveries without negatively affecting the recovery of revenue minerals. It was noted, however, that the use of Cu selective reagents on the “low” pyrite sample resulted in a 6% decrease in Au and Mo recovery.

The decision was made, therefore, to use the standard xanthate collector suite in the rougher circuit, and manage pyrite content within the cleaner circuit. This strategy may need revision once the pyrite distribution across the ore body is more comprehensively understood.

For all rougher optimization test work conducted, recovery of Cu exceeded 91%.

#### **13.1.2.2.1.2 Cu Cleaner Circuit Optimization**

Test work conducted in 2009 demonstrated the benefits of bulk cleaning of the rougher concentrates. The major observations were that the bulk cleaning process could significantly improve concentrate grades with little impact on major revenue minerals. Salient discussion points arising from this test work were as follows:

- Cu upgrade ratios for samples of low pyrite content were in excess of two, with Cu stage recoveries of up to 98%. Ores with higher pyrite content were not able to upgrade as successfully as the low pyrite samples.
- The most significant loss in Mo recovery was 2.6%.



### **13.1.2.2.1.3 Preliminary Investigation of Cu/Mo Separation**

A preliminary, single stage Mo rougher test was conducted to establish the viability of the process. In order to achieve this, NaHS was introduced to a bulk Cu rougher concentrate to depress the Cu minerals present. Note that no Mo collector was added.

The outcomes were that a Cu/Mo separation was possible, with Cu recovery to the Mo tails ranging from 82-88%. Mo recovery ranged from 72 to 78% to the Mo rougher concentrate, at grades of up to 8%. The results indicated that several cleaning stages, and possibly a concentrate regrind step, would be required to achieve the required concentrate specification of 50% Mo.

### **13.1.2.2.1.4 Ageing Test work**

The proposed plant layout for the process plant was to separate comminution at the mine area from the flotation plant at the coast. This required transportation of milled feed from the mine site to the process plant. It was, therefore, necessary to establish if this transportation process would affect metallurgical performance.

In order to establish these effects, a milled sample was placed in a sealed jar and was bottle-rolled for a period of 14 hours (to simulate residence time in the pipeline). Rougher flotation tests were conducted thereafter to establish the metallurgical performance.

The outcomes of the rougher rate test work were as follows:

- The test work indicated that there was a reduction in mass pull after aging for 14 hours.
- Cu recovery losses because of aging were less than 1% for the bulk of samples treated.
- Mo recoveries were affected by aging with an absolute recovery loss of 2.5%.
- The aging process did not affect Au recovery.

### **13.1.2.2.2 2011/2012 ALS – AMMTEC Test work Campaign**

#### **13.1.2.2.2.1 Sample Selection**

This test work campaign was referred to as the “C Series” test work campaign. The sample provenance is discussed in the relevant section of this Report. Samples were derived from several drill cores at various locations in each of the deposits.

Composite selection was grade based and did not consider lithology, alteration or depth. These, therefore, represented an overall impression of the average composition of each ore body.

#### **13.1.2.2.2.2 Rougher Optimization Studies**

This test work campaign was conducted on three composite samples derived from borehole cores from the Omora, Gremi and Imbruminda deposits – referred to as the C4, C5 and C6 composites respectively.

The purpose of the work was to confirm that conditions established in the 2009 test work programme were appropriate for the new sample set received. All tests in this series were conducted as rougher rates.



The following work was undertaken:

- Feed slurry density was varied from 25% to 45%, and it was confirmed that 35% was the most optimal feed density for these ore types.
- The effect of grind on overall metallurgical performance as well as rougher kinetics was executed at grinds of 125 µm, 150 µm and 180 µm. The scope of work confirmed the original assessment that the optimal grind for these deposits was 150 µm.
- Xanthate collectors were compared to the use of Cu selective reagents (A208, A3894, RTD 1481, A8761). The outcome of this study was that the use of PAX provided the highest recoveries, and should be adopted as rougher conditions.

Table 13-2 compares rougher rate test work performance for the three ore bodies, based on the following conditions:

- a laboratory residence time of 12 minutes;
- feed slurry density of 35% solids;
- flotation grind of 80% passing 150 µm; and
- Addition of PAX as collector.

Cu recoveries in excess of 96% were attainable for all samples tested under the proposed rougher flotation conditions. Molybdenum recoveries to concentrate were above 87%, and gold recovery varied from deposit to deposit. Mass pulls to rougher concentrate were consistently between 3-4%. Copper rougher concentrate upgrade ratios ranged from 26 for Omora to 36 for Imbruminda, and would be a function of the pyrite content as well as predominant Cu minerals present in the feed.

**Table 13-2: Comparison of Rougher Flotation Performance of Omora, Gremi and Imbruminda Utilizing Proposed Rougher Flotation Conditions**

Performance Indicator	Omora (C4)	Gremi (C5)	Imbruminda (C6)
<b>Head Grades ( Average deposit grade in brackets)</b>			
Cu (%)	0.35 (0.37)	0.49 (0.50)	0.48(0.52)
Mo (ppm)	150 (184)	150 (198)	155 (176)
Au (g/t)	0.03 (0.03)	0.12 (0.12)	0.21 (0.24)
<b>Mass Pull to Rougher Concentrate</b>			
Mass Pull based on mill feed (%)	3.93	3.81	3.11
<b>Recovery</b>			
Cu (%)	96.3	97.1	95.9
Mo (%)	89.7	89.6	87.7
Au (%)	69.8	90.8	82.5
<b>Concentrate Grade</b>			
Cu (%)	10.1	13.3	17.5
Mo (%)	0.3	0.43	0.44
Au (g/t)	0.6	2.5	5.9



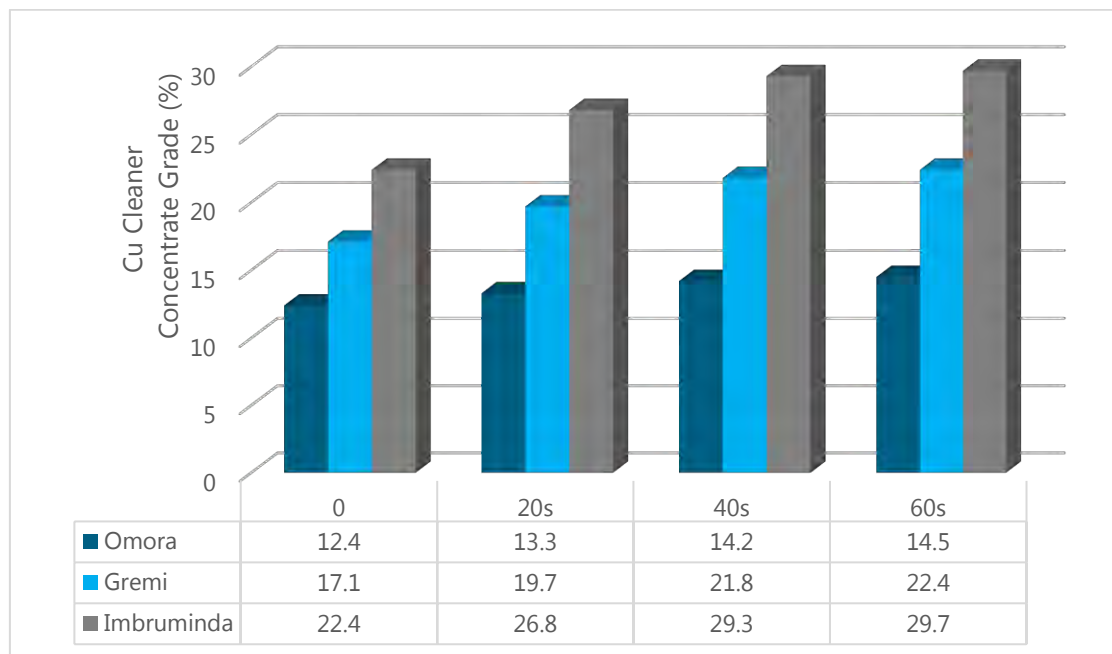
### 13.1.2.2.2.3 Cleaner Optimization Studies

Once the rougher conditions for test work were established, a series of cleaner optimization tests were conducted on the Omora, Gremi and Imbruminda master composites (C4, C5, and C6). The focus of these studies was to:

- Establish the required cleaner circuit configuration (number of stages).
- Establish the benefits of Cu rougher concentrate regrind (if any) and most appropriate regrind size.
- Develop an understanding of mechanisms to depress pyrite in the cleaner circuit, including effect of pH and use of alternative Cu collectors.

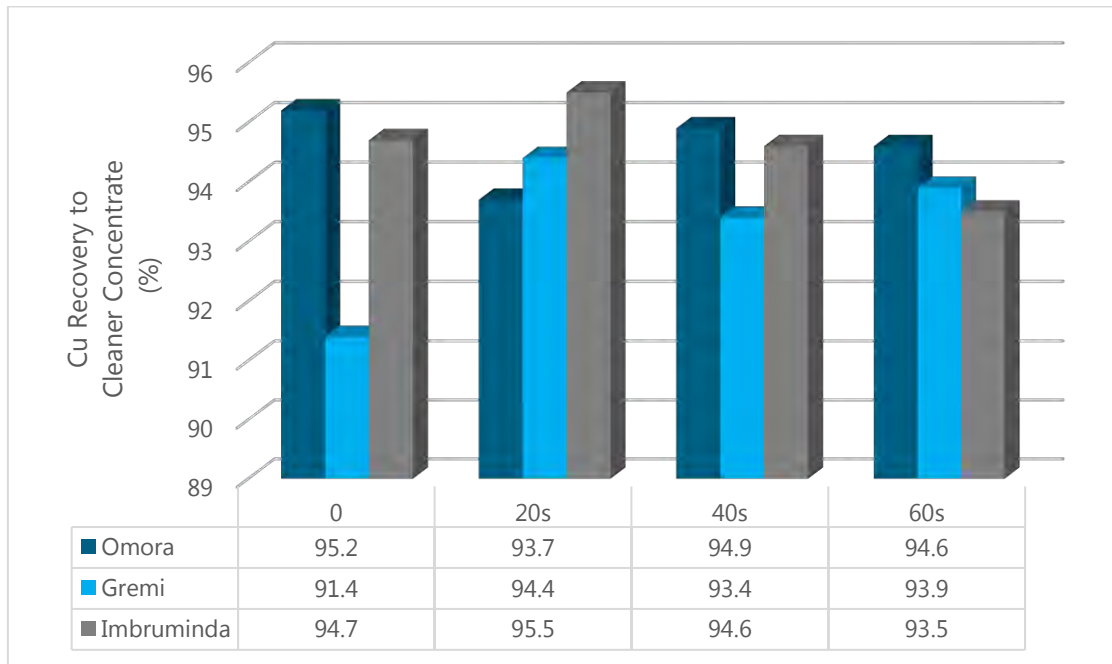
It was noted that the rougher concentrates derived from each of the deposits could be upgraded with little impact to Cu, Mo and Au recoveries. In addition, concentrates would require regrind and a minimum of two cleaning stages to achieve concentrate grades in excess of 25% Cu, as shown in refer to Figure 13-11.

Figure 13-12 to Figure 13-13 show that regrinding of the concentrate had with little impact on concentrate recoveries. It was noted that very little metallurgical improvement was obtained at grinds finer than 40  $\mu\text{m}$ , and this was therefore used for further test work.

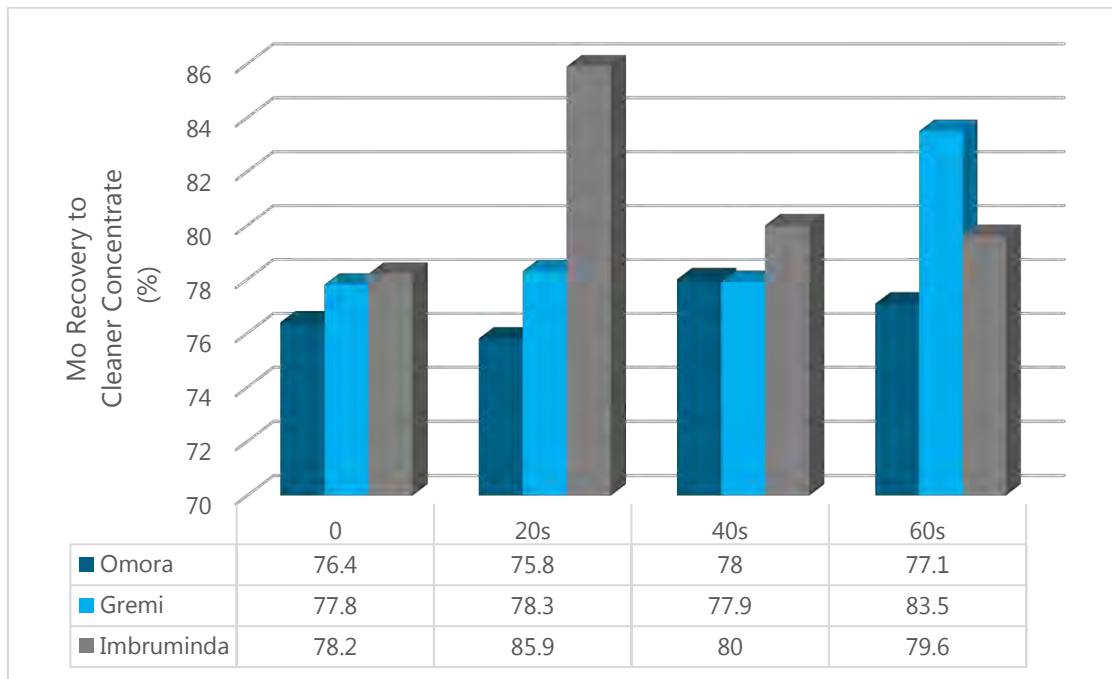


**Figure 13-11: Effect of Grind on Cu Cleaner Concentrate Grade**





**Figure 13-12: Effect of Grind on Cu Cleaner Recovery**



**Figure 13-13: Effect of Grind on Mo Cleaner Recovery**

It was observed that the Omora composite did not achieved concentrate grades equivalent to those obtained for the Gremi and Imbruminda composites. Examination of the achieved concentrate grades suggests that the major Cu mineralization is chalcopyrite and bornite, and this distribution across the ore body will dictate the potential upgrading of these samples. In this instance it would appear that the Imbruminda samples would have bornite present, and the Gremi and Omora samples would be chalcopyrite rich, based on the concentrate grades attained.



Mineralogical investigation of the Omora rougher concentrate established that this sample contained some unliberated chalcopyrite associated with non-sulphide gangue, which could be liberated through the regrind process. However, a significant proportion of liberated coarse pyrite grains, which will report to the cleaner concentrate.

A series of tests was conducted, therefore, to investigate various mechanisms for pyrite removal in the cleaner stages of flotation, specifically from the Omora composite. Mechanisms investigated included:

- effects of pH adjustment (two tests at pH of 11 and 12 respectively);
- use of Cu selective collectors in the cleaning stages;
- use of NaCN, SMBS and DETA as pyrite depressants as well as CMCs and Na<sub>2</sub>SiO<sub>3</sub> for non-sulphide gangue depression; and
- Finer regrind sizes.

The outcomes of this study indicated that concentrate grades could be increased using SMBS or NaCN or pH adjustment for pyrite depressant in a two-stage cleaner circuit. Based on the composite tested, a concentrate grade of 30% could be attained by this method, at Cu recoveries in excess of 89%. However, significant Au losses to cleaner tails were noted because of the use of a pyrite depressant. It is anticipated that this is the result of Au association with pyrite.

#### **13.1.2.2.2.4 Cu/Mo Separation and Mo Cleaning Circuit**

Bulk concentrate production test work was conducted on the Omora, Gremi and Imbruminda composites (C4, C5, and C6) to produce sufficient Cu cleaner concentrate to define the Mo flotation circuit. Three preliminary Mo rougher/cleaner tests were conducted to establish the viability of producing a Mo concentrate. The flowsheet investigated included a single Cu cleaner/scavenger stage, Cu depression by means of Controlled Potential Sulphidization (CPS) (NaSH) in the Mo rougher as well as three Mo cleaning stages. The results indicated that the Cu/Mo split could successfully be executed without significant loss of recovery to the final copper concentrate, and that the Mo concentrate could be upgraded via cleaning. It was noted that more than three cleaner stages would be necessary to attain saleable grade products. This would potentially also include regrinding of the Mo concentrate in order to produce a final Mo concentrate of appropriate grade.

This work was undertaken as part of the locked cycle test work series.

#### **13.1.2.2.2.5 Locked Cycle Test work**

Locked cycle test work was executed on the Gremi and Imbruminda composites (C5 and C6), as well as a LoM blend comprising Omora, Gremi and Imbruminda samples in the proposed ratio over average LoM (15% Omora, 35% Gremi and 50% Imbruminda) . An additional sample sourced from an adit at Gremi was also included in the locked cycle programme.

The locked cycle test work programme had the objective of investigating:

- the effect of additional Cu cleaning stages on final concentrate grade;



- the number of Mo stages required to obtain concentrate grades in excess of 40% for sale; and
- The effect of regrind of the Mo circuit. In this instance, a regrind size of 100% passing 30 µm was applied.

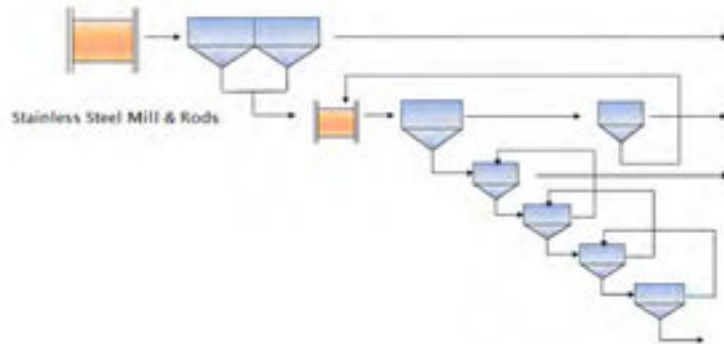
In order to achieve this objective, three test work configurations were examined. These flowsheets are presented in Figure 13-14. A summary of the results obtained are presented in Table 13-3 to Table 13-5 .

**Table 13-3:- Summary of Locked Cycle Test Work – Configuration 1**

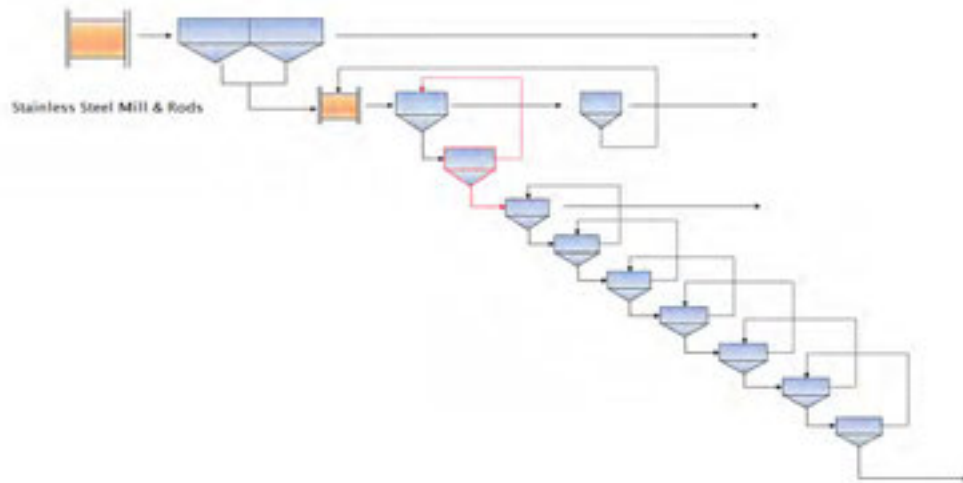
Sample ID	Head Grade Cu (%)	Head Grade Mo (%)	Cu Concentrate			Mo Concentrate		
			Mass Pull (%)	Cu Recovery (%)	Cu Conc Grade (%)	Mass Pull (%)	Mo Recovery (%)	Mo Conc Grade (%)
Gremi Composite (C5)	0.48	0.025	2.05	96.4	22.4	0.04	65.8	39.0
Imbruminda Composite (C6)	0.52	0.0152	1.62	94.6	30.6	0.03	73.5	43.9
LoM Composite (C8)	0.48	0.0194	1.89	95.5	24.4	0.04	76.3	39.3
Gremi Adit	Not Tested							



Configuration 1 :- Single Stage Cu Cleaner/Scavenger Circuit, with Mo Rougher and Three Stage Cleaning ( No Regrind)



Configuration 2 :- Two Stage Cu Cleaner/Scavenger Circuit, with Mo Rougher and Seven Stage Cleaning ( No Regrind)



Configuration 3 :- Two Stage Cu Cleaner/Scavenger Circuit, with Mo Rougher and Seven Stage Cleaning ( Mo Regrind)

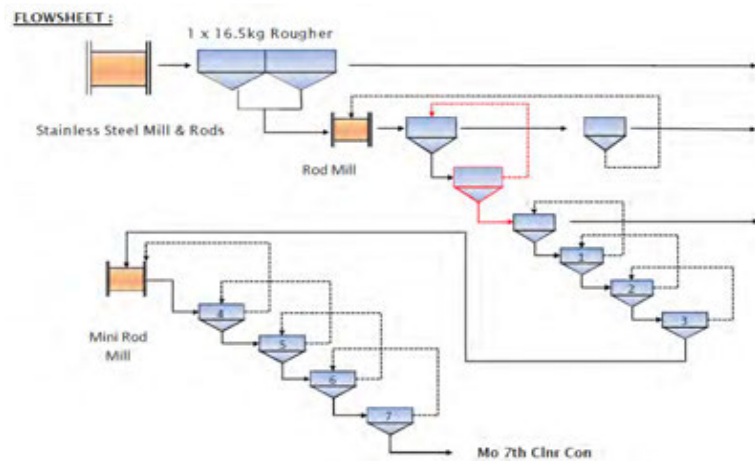


Figure 13-14: Process Flowsheet Configurations for Locked Cycle Test Work



**Table 13-4: - Summary of Locked Cycle Test Work – Configuration 2**

Sample ID	Head Grade Cu (%)	Head Grade Mo (%)	Cu Concentrate			Mo Concentrate		
			Mass Pull (%)	Cu Recovery (%)	Cu Conc Grade (%)	Mass Pull (%)	Mo Recovery (%)	Mo Conc Grade (%)
Gremi Composite (C5)	Not Tested							
Imbruminda Composite (C6)	Not Tested							
LoM Composite (C8)	0.48	0.0194	1.31	95.4	34.9	0.03	70.5	51.4
Gremi Adit	Not Tested							

**Table 13-5:- Summary of Locked Cycle Test Work – Configuration 3**

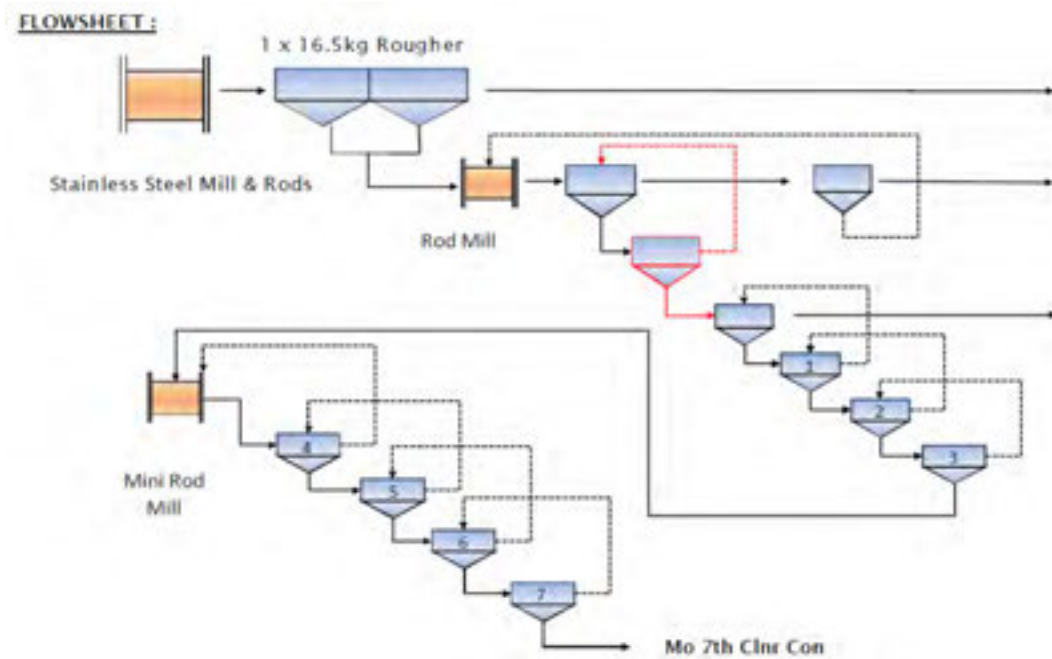
Sample ID	Head Grade Cu (%)	Head Grade Mo (%)	Cu Concentrate			Mo Concentrate		
			Mass Pull (%)	Cu Recovery (%)	Cu Conc Grade (%)	Mass Pull (%)	Mo Recovery (%)	Mo Conc Grade (%)
Gremi Composite (C5)	Not Tested							
Imbruminda Composite (C6)	Not Tested							
LoM Composite (C8)	Not Tested							
Germi Adit	0.39	0.021	0.09	95.8	41.6	0.04	86	43.3

Based on the results presented, it would be prudent to incorporate a second Cu cleaner stage to the process flowsheet, as this will ensure that the Cu concentrates produced are within the required specification. In addition, it was noted that Mo concentrate grades were increased marginally by increasing the number of cleaning stages from three to seven. It would appear that a marginal improvement in Mo concentrate grade and overall recovery could be achieved through a regrind stage. However, it is acknowledged that the benefits of regrinding the Mo concentrate are not fully quantified or established at the conclusion of this work. It is recommended that the impacts of Mo concentrate regrind be investigated as part of the DFS work programme to determine whether the recovery of a separate Mo concentrate is viable.

Locked cycle test work was conducted on three additional low-grade samples derived from Omora, Gremi and Imbruminda as a means of confirming metallurgical performance through the proposed flowsheet on low-grade ore samples. Samples were derived from remaining core from the 2011 drilling programme.



The test work flowsheet is presented in Figure 13-15.



**Figure 13-15: Locked Cycle Test Work Flowsheet – Low-grade Samples**

The proposed flowsheet (and reagent additions) were as follows:

- Cu rougher flotation was conducted at a grind of 80% passing 150 µm, at 35% solids. The tests were conducted at a natural pH, using PAX as collector and MIBC as a frother.
- A two stage cleaner circuit, with a scavenger cleaner, was employed for upgrading of the Cu concentrate. The Cu concentrate was reground to 100% passing 40 µm prior to cleaner flotation. PAX and kerosene were used as for Cu and Mo collection respectively, and flotation was conducted at natural pH. No pyrite depressant was included.
- Copper depression in the Mo rougher was conducted using NaHS added to a controlled potential of -500mV. A small amount of kerosene was added as a Mo collector.
- The Mo cleaner circuit comprised seven cleaning stages. A Mo regrind stage was conducted at the completion of the third cleaner stage. The third concentrate was reground to 100% passing 30 µm, followed by four additional stages of cleaning. In the final four stages of cleaning, NaHS was added to a controlled potential of -500mV.

The results of the locked cycle test work is presented in Table 13-6.

**Table 13-6: Low-grade Locked Cycle Test work Results**

Sample ID	Head Grade Cu (%)	Head Grade Mo (%)	Cu Concentrate			Mo Concentrate		
			Mass Pull (%)	Cu Recovery (%)	Cu Conc Grade (%)	Mass Pull (%)	Mo Recovery (%)	Mo Conc Grade (%)
Omora Low-grade Composite	0.38	0.0181	1.80	94.9	19.8	0.03	65.9	44.5
Gremi Low-grade Composite	0.38	0.0142	1.18	95.9	31.2	0.02	68.8	41.5





Sample ID	Head Grade Cu (%)	Head Grade Mo (%)	Cu Concentrate			Mo Concentrate		
			Mass Pull (%)	Cu Recovery (%)	Cu Conc Grade (%)	Mass Pull (%)	Mo Recovery (%)	Mo Conc Grade (%)
Imbruminda Low-grade Composite	0.32	0.010	0.91	94.5	33.3	0.02	69.3	43.9

All low-grade hypogene composites achieved final copper recoveries greater than 94%. Final copper concentrate grades were above 30% Cu with the exception of Omora, which, as previously noted, has higher levels of pyrite. Omora pyrite suppression test work has shown that final copper concentrate grades of over 30% Cu can be achieved using reagent adjustments/additions. Final molybdenite concentrate recoveries and grades were greater than 65% and 40% Mo respectively for all low-grade hypogene composites.

The conditions and flowsheet presented in Figure 13-15 produced an appropriate outcome for the production of the required Cu and Mo concentrates at head grades similar to those anticipated as average resource grade. This configuration, therefore, forms the basis for process engineering design for the PFS.

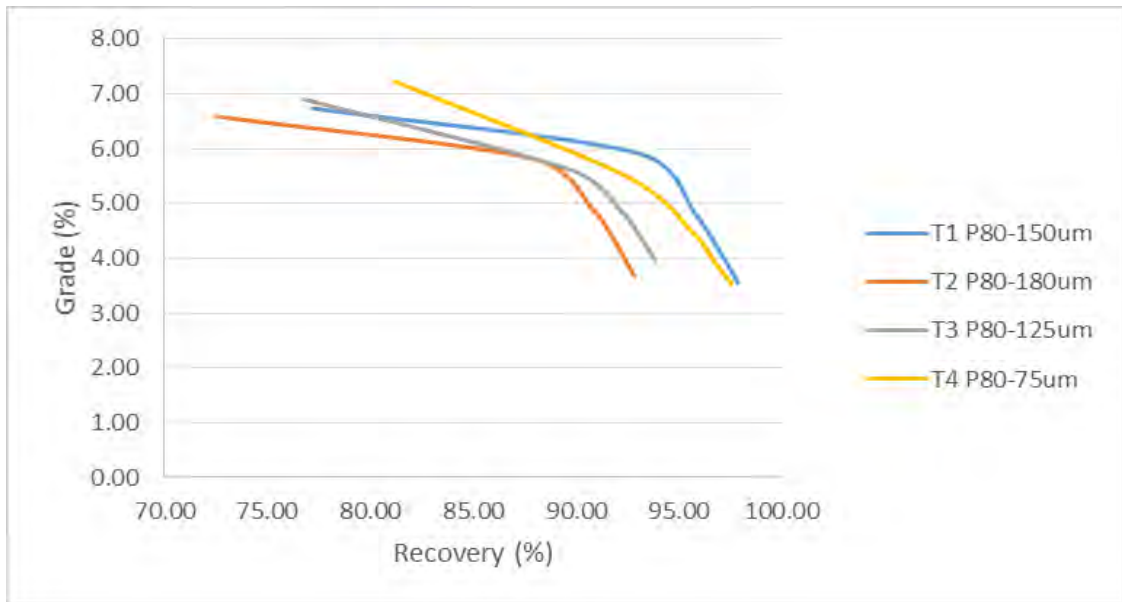
### 13.1.2.2.3 Metallurgical Performance of Dimbi Sulphide Sample

Additional flotation work was conducted in 2017 on a composite sample derived from the Dimbi ore body. The sample was derived from several cores along the strike of the ore body. Test work was conducted at Mintek in South Africa, under the direction of Advisian. The objective of the scope of work was to conduct a preliminary characterization of the Dimbi ore body, and compare the metallurgical performance of this ore to the Gremi, Omora and Imbruminda samples tested previously.

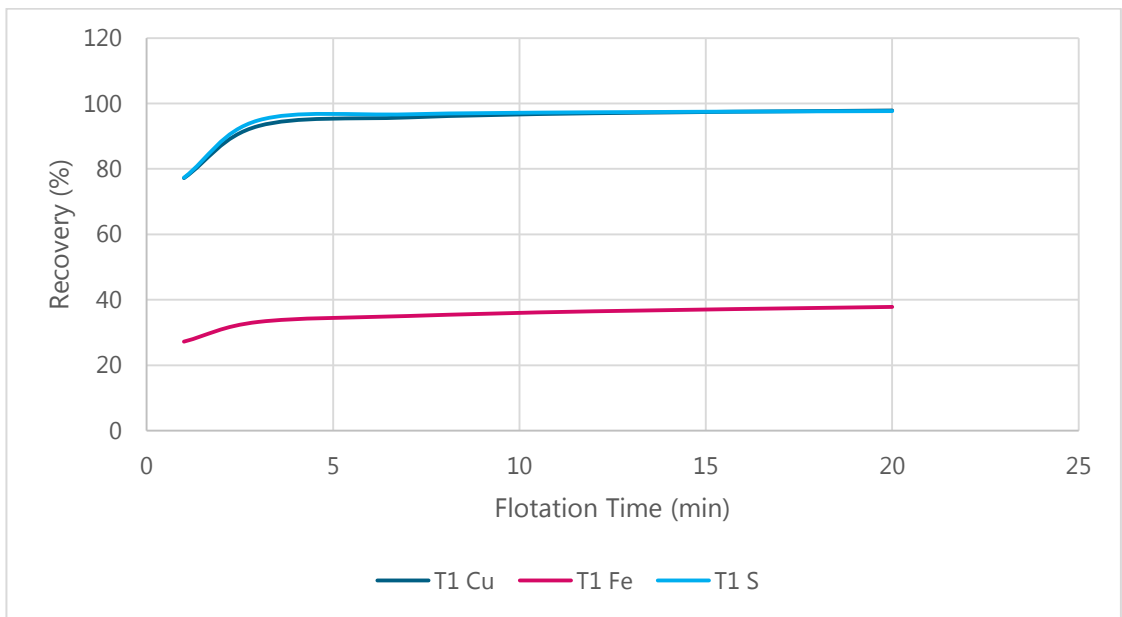
The sample contained 0.4% Cu and 103ppm Mo. Copper present in the composite occurred predominantly as chalcopyrite, with trace amounts of bornite. Pyrite content contributed approximately 4% of the feed material, and the major non-sulphide gangue components were quartz, feldspar and muscovite. At the target grind size of 80% passing 150 µm, the major gangue association with chalcopyrite grains was with non-sulphide gangue such as Fe oxides and quartz. Minor association of chalcopyrite with pyrite was observed.

Grind –recovery test work on the Dimbi sample was conducted at grinds ranging from 75 µm to 212 µm. This series of tests was conducted using the same reagent suite as the 2011/2012 test work campaign (PAX as collector and MIBC). The test work results indicated that Cu rougher recoveries of 95% and above could be obtained at coarse grinds, as illustrated in Figure 13-16.

In addition, the composite sample of the Dimbi ore body exhibited similar flotation kinetics to that observed for the other target zones examined, as illustrated in Figure 13-17. It was observed that Cu was fast floating, and that the kinetic profile of pyrite was similar to that of Cu-bearing minerals, based on Fe and S flotation kinetics.



**Figure 13-16: Effect of Grind on Cu Recovery – Dimbi Samples**



**Figure 13-17: Effect of Grind on Cu Recovery – Dimbi Samples**

The mass pulls attained for these tests were significantly higher than observed for previously conducted rougher test work (approximately 10 to 11% of mill feed compared to approximately 3 to 4% for other samples tested) and the rougher upgrade ratio was approximately nine times the head grade, which was low in comparison to previous work executed. This was attributed to the high pyrite content, which dilutes the rougher concentrate.



In order to reduce the mass pull to the rougher concentrate and to prevent pyrite activation, the PAX dosage was reduced to 30% of the original prescribed dosage. By doing this, the rougher concentrate mass pull could be reduced from 11% to approximately 7% without negatively affecting Cu recovery. Further attempts to reduce this mass pull in the rougher flotation stage included:

- Addition of DETA into the mill ahead of rougher flotation. This, however was not effective at reducing pyrite content in the rougher concentrate, and could not reduce rougher mass pull.
- Increase of flotation pH via lime addition. It was noted that the pH would need to be raised to as high as 12 to attain mass pulls within the target range of 3-4%, and the use of this technique resulted in a significant decrease in Cu recovery (approximately 10%).
- In an attempt to improve recovery at high pH conditions, a highly selective Cu selector (A3418A) was substituted for PAX. The outcome of this test was that a 6% mass pull could be attained but that recovery decreased to 92%.

It is therefore concluded that the proposed rougher flotation circuit, with PAX collector, should be retained for cleaner work, and that strategies for managing pyrite in the cleaner circuit should be investigated.

Cleaner/recleaner rate test work was conducted without a concentrate regrind, and at regrind of 53  $\mu\text{m}$  and at 40  $\mu\text{m}$ . The pH in the cleaner circuit was increased to 11 using lime as a means of pyrite depression. The outcomes of this work were that two stages of cleaning and a concentrate regrind at 40  $\mu\text{m}$  were required in order to achieve the required target concentrate grade. This confirmed previous test work findings. The use of SMBS as a pyrite depressant in conjunction with elevated pH was investigated, and it was established that this could be used effectively to produce concentrates of the required grade but with associated recovery losses.

It was concluded that the Dimbi samples were similar in nature to samples previously tested from Gremi, Omora and Imbruminda. The composite received from the Dimbi area has similar metallurgical responses to samples previously tested and, therefore, the proposed flowsheet would be suited for extraction of Cu and Mo from this ore body. The scoping test work conducted on the Dimbi composite further iterates the need to establish a thorough understanding of pyrite distribution within the Yandera ore bodies, and develop a solid strategy for pyrite management as part of DFS test work.

### **13.1.2.3 Flotation Test Work on Oxide and Transitional Ores**

#### **13.1.2.3.1 Preliminary Scoping Studies (2011/2012)**

As part of the "C-series" test work campaign, an oxide composite and a mixed (transitional) ore composite (referred to as C1 and C2 respectively) were generated for metallurgical test work. The basis for classification of oxide and mixed material was the geologist's visual interpretation. The composites comprised an appropriate blend of material from Gremi, Omora and Imbruminda drill cores. These samples were used for a full series of metallurgical tests, ranging from basic rougher tests to locked cycle tests.



Outcome of this work included:

- Oxide test work indicated that Cu recoveries ranged from 55 to 58% for concentrate grades of 25% Cu and 60 to 62% for concentrate grades of 20% Cu. Locked cycle test work at BGRIMM indicated that a 61% Cu recovery could be attained at a concentrate grade of 23.6% Cu.
- The mixed ore sample yielded a 78.9% Cu recovery at a final concentrate grade of 35.2% Cu.

In late 2012, Era decided to reclassify oxide and mixed ore recoveries based on sulphur to copper ratio (S:Cu ratio) as the geologist’s use of visual classification, i.e. disappearance of iron oxide staining, to determine the top boundary of fresh rock did not properly reflect flotation test work results for metal recoveries and copper recovery in particular. For this reason, details of test work conducted on the C1 and C2 composites are not reported in detail, as they are not necessarily true representations of the oxide and mixed ore zones.

A statistical analysis of the drillhole assay data indicated three broad zones of S:Cu ratios that appear to be indicative of oxide, mixed and fresh (hypogene) ore zones. Additional half core samples were acquired from the drill core warehouse for a new mixed ore test work programme.

The focus of the study was the Gremi ore deposit as this was the source of early ore for the Project at the time. Various samples were identified to perform rougher flotation testing to determine metal recovery under standard circuit conditions:

- Primary grind at p80 = 150 µm.
- Flotation feed density of 35%.
- PAX addition as collector and MIBC as frother.

An Era geologist assisted in the selection of 11 Gremi composites, which exhibited secondary copper and oxide minerals, typical of a mixed sample. Bulk rougher tests were performed on these composites and the addition of NaHS at the scavenger stage increased copper recovery. Results are presented in Table 13-7.

**Table 13-7: Gremi Mixed Ore Samples Sighter Tests on Low S:Cu Ratio, High Visual Oxide with Effect of NaHS Addition**

Composite ID	Calculated Head Grade (%)		Combined Rougher and Scavenger Concentrates					Tails	
	Cu	S	Mass Pull (%)	Cu		S		Cu (%)	S (%)
				Grade (%)	Rec (%)	Grade (%)	Rec (%)		
Comp 1	0.439	0.1189	1.68	10.9	41.6	5.16	72.8	0.23	0.02
Comp 2	0.679	0.2979	2.01	15.0	44.5	8.52	57.5	0.19	0.04
Comp 3	0.230	0.0365	5.15	0.90	20.2	0.34	48.0	0.19	0.02
Comp 4	0.149	0.0904	1.56	8.38	87.8	4.52	78.2	0.02	0.02
Comp 5	0.252	0.1036	1.44	0.91	5.19	4.68	65.1	0.24	0.02
Comp 6	0.511	0.1104	2.79	6.04	33.0	2.54	64.1	0.32	0.03
Comp 7	0.380	0.0887	1.31	8.78	30.4	4.68	69.4	0.24	0.02



Composite ID	Calculated Head Grade (%)		Combined Rougher and Scavenger Concentrates					Tails	
			Mass Pull (%)	Cu		S		Cu (%)	S (%)
	Cu	S		Grade (%)	Rec (%)	Grade (%)	Rec (%)		
Comp 8	0.373	0.1100	3.06	11.5	94.3	2.96	82.4	0.02	0.02
Comp 9	0.166	0.0491	1.40	1.29	10.9	1.68	47.9	0.14	0.02
Comp 10	0.212	0.0805	1.36	8.96	57.6	5.20	87.8	0.09	0.01
Comp 11	0.296	0.0970	1.53	10.8	56.0	4.40	69.5	0.13	0.03

The results indicate that Cu recovery ranged from as low as 5% for composite 5 to 94.3% for composite 8. In addition, concentrate upgrading was poor for some of the samples (Composite 3, Composite 5 and Composite 9). It was noted that the increase in Cu recovery because of the addition of a sulphidization stage ranged from 1% up to 28%, demonstrating the variable nature of the mixed ore zone.

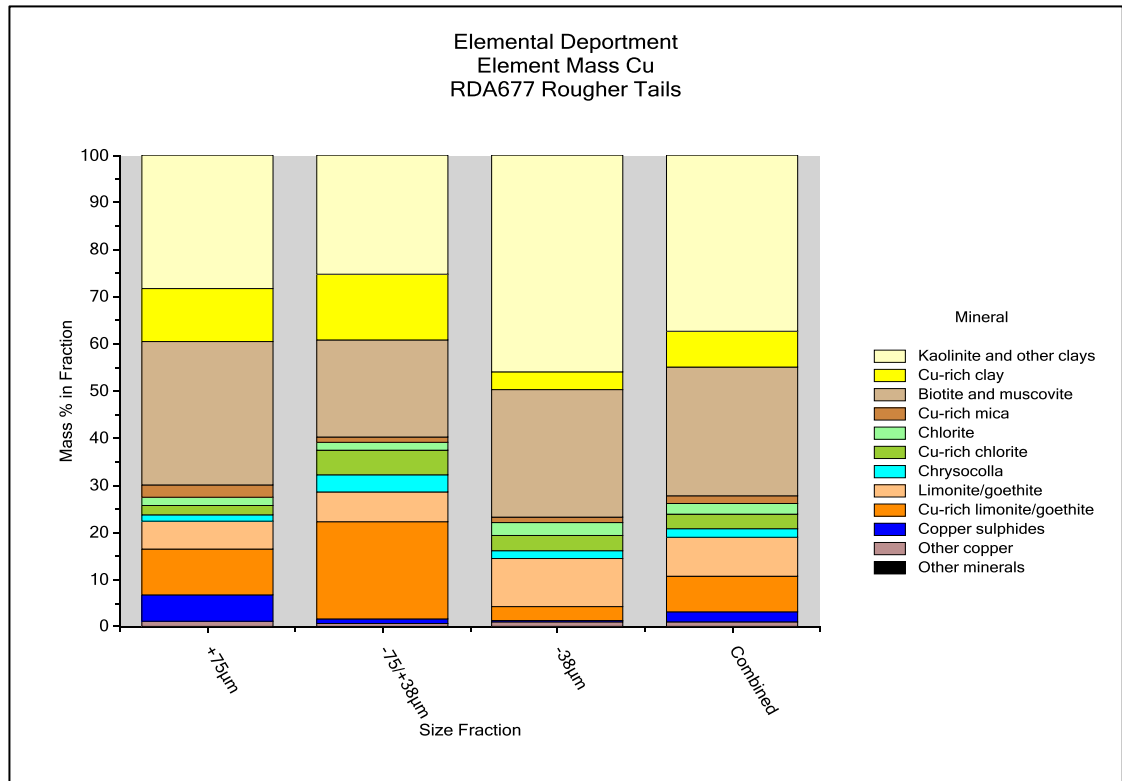
Further optimization test work was conducted on a mixed master composite, including:

- Test 1 – Standard PAX collector with addition of NaSH to a controlled potential of -100mV.
- Test 2 – Standard PAX collector with addition of NaSH to a controlled potential of -200mV.
- Test 3 – Standard PAX collector with addition of NaSH to a controlled potential of 0mV.
- Test 4 – Standard PAX collector with addition of NaSH to a controlled potential of -100mV and pH increased to 9.
- Test 5 – Standard PAX collector with addition of NaSH to a controlled potential of -100mV and pH decreased to 6.
- Test 6 – Standard PAX flotation test with addition of Na<sub>2</sub>S to a controlled potential of -100mV.
- Test 7 – Standard PAX flotation test with addition of Na<sub>2</sub>S to a controlled potential of -200mV.
- Test 8 – Standard PAX flotation test with addition of Na<sub>2</sub>S to a controlled potential of 0mV.
- Test 9 – Double PAX collector with NaSH added to a controlled potential of -100mV.
- Test 10 – Standard PAX flotation test with NaSH added to -100mV, Aero 6493 and Aero 3418A added.
- Test 11 – Standard PAX flotation test with Aero 6493 added.

The highest recovery achieved was 62% Cu recovery. This was achieved at a final ORP at -100mV using NASH as sulphidizing agent. The Cu tailings grades of all tests ranged from 0.15 to 0.20% Cu, suggesting that there is a mineralogical driver, which limits Cu recovery for these composites. Mineralogical evaluation of the rougher flotation tailings of one of the composites indicated that little of the Cu losses to the rougher tails were attributed to Cu sulphide or oxide mineral species, but rather to Cu occurring within typical gangue phases, such as Cu-rich clays, Fe oxides, micas and chlorites as presented in Figure 13-18.



Copper in this form (where Cu occurs within the lattice structure of the gangue mineral) is classified as non-floatable and, therefore, will not be recovered by flotation.



**Figure 13-18: Cu Department in the Rougher Tailings**

Mixed ore composites derived from the Omora and Imbruminda deposits were also tested, and these performed significantly better than the composites prepared from Gremi. The Imbruminda sample attained a Cu recovery of 79% Cu at a final concentrate grade of 34.6% Cu and the Omora sample achieved a Cu recovery of 80% Cu at a concentrate grade of 31.4% Cu.

### 13.1.2.3.2 Flotation Scoping Test Work on Oxide and Samples from Gremi (2017)

Oxide samples were used for a previous metallurgical test work campaign at McClelland Laboratories in Reno. The sample set comprised six samples of varying Cu head grade, all derived from the oxide zone. Test work was conducted to establish rougher metallurgical performance making use of CPS via addition of NaHS, as well as the addition of a hydroxamate for enhanced recovery. Test work was conducted at a grind of 80% passing 150µm.

The results of the test work were inconclusive. Further test work is recommended. Initial results are shown in Table 13-8 (see Appendix A for further analysis).





**Table 13-8: Rougher Flotation Results –Gremi Oxide**

Sample ID	Head Grade Cu (%)	Mass Pull (%)	Cu Recovery (%)	Au Recovery (%)
YD139	0.467	10.3	28.6	20.0
YD140	0.453	14.3	31.3	25.1
YD252	0.254	9.6	23.0	64.9
YD346	0.352	12.6	26.8	16.0
YD356	0.305	10.2	51.3	54.0
YD517	0.463	13.5	34.4	20.0

Average Cu recovery for test work on these composite samples ranged from 23% to 51.3%, with an average Cu recovery of 33% for the total data set. Gold recovery ranged from 16% to 64%.

Mineralogical evaluation of each of these composites yielded the following findings:

- Only a relatively small portion (10% to 21%) of the Cu occurred as copper minerals except for composite YD356. Of this portion, 2% to 5% were primary sulphide minerals (chalcopyrite, bornite), 2 % to 4 % were secondary sulphide minerals (chalcocite, covellite), and 2 % to 13 % were oxide copper minerals (malachite, chrysocolla, crednerite).
- The vast majority (79% to 90%) of the copper in these five composites was actually associated with clay (rectorite/montmorillonite), biotite/phlogopite, chlorite and goethite. The Cu in these mineral types is substituted into the lattice of these minerals as is therefore chemically combined. These were not recoverable by flotation.

The mineralogical findings correspond well to the flotation test work outcomes as demonstrated in Table 13-9. The correlation between the model analysis and the flotation test work results is good.

**Table 13-9: Comparison of Gremi Oxide Result to Modal Analysis**

Sample ID	Cu Recovery (%)	Cu Department to Cu Minerals (%)	Cu Department to Gangue Phases (%)
YD139	28.6	21.4	78.6
YD140	31.3	16.5	83.5
YD252	23.0	9.6	90.4
YD346	26.8	15.7	84.3
YD356	51.3	57.5	42.5
YD517	34.4	21.4	78.6



### 13.1.3 Studies in Support of Engineering Design

#### 13.1.3.1 Scope of Engineering Studies

As part of the 2012/2013 test work programme, a bulk concentrate sample was produced from a global hypogene/sulphide LoM composite to conduct the engineering and vendor test work required for process design purposes. A bulk composite was prepared from the master composites used for the 2011 and 2012 test work campaigns, with the following composition:

- 15% Omora.
- 35% Gremi.
- 50% Imbruminda.

The bulk samples were used to establish requirements for various test work programmes, including :

- Cu concentrate-specific regrind energy requirements (Levin test).
- Tailings thickening test work.
- Tailings characterization for slurry pumping.
- Concentrate thickening and filtration test work.
- Concentrate handling characteristics.
- Concentrate quality.

This section summarizes the scope of work and relevant outcomes of these studies.

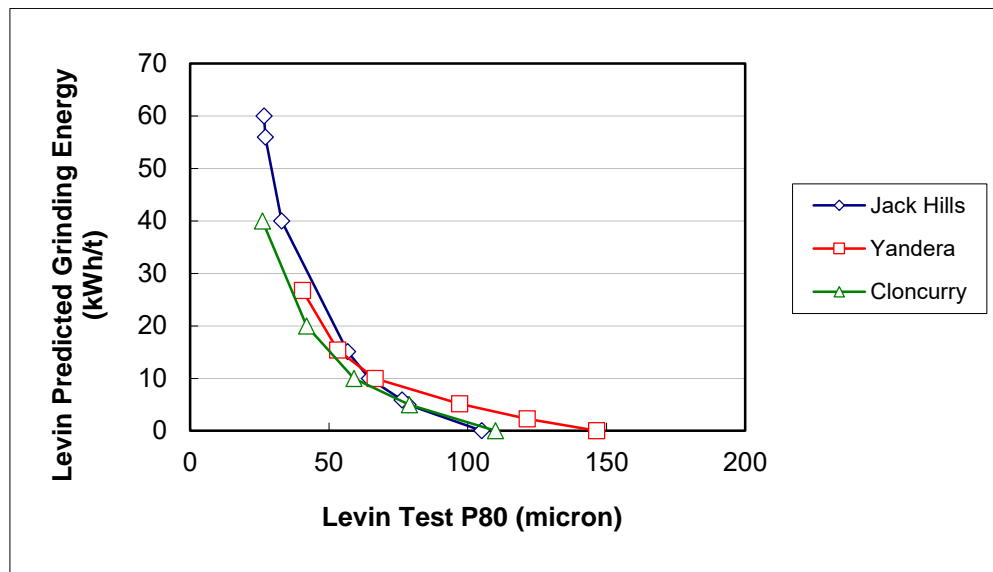
#### 13.1.3.2 Concentrate Regrind Specific Energy Test Work

The Levin regrind index test was conducted to establish the power requirements to obtain the required Cu rougher concentrate regrind of 80% passing 40 µm. In this test, samples of approximately 500g of material are ground using four power inputs (15kWh/t, 20kWh/t, 30kWh/t and 40kWh/t). The samples are sized to establish which of the energy inputs produces the required size distribution. This test work was conducted at ALS-Ammtec in Australia.

The outcomes of this test work are presented in Table 13-10, and the results are benchmarked against similar operations in Figure13-19.

**Table 13-10: Summary of Levin Regrind Index Results**

Energy Input (kWh/t)	P80 Size (µm)
15	48
20	41
30	30
40	23



**Figure13-19: Comparison of Yandera Levin Test Results to Similar Ore Types**

The specific energy requirement to achieve a grind of 80 % passing 40  $\mu\text{m}$  is 21kWh/t, based on the results of the Levin test. Future work in this area would, however, include confirmation of this number via vendor-conducted test work, as each vendor has its own specific test work procedure and adapts this accordingly for equipment sizing purposes.

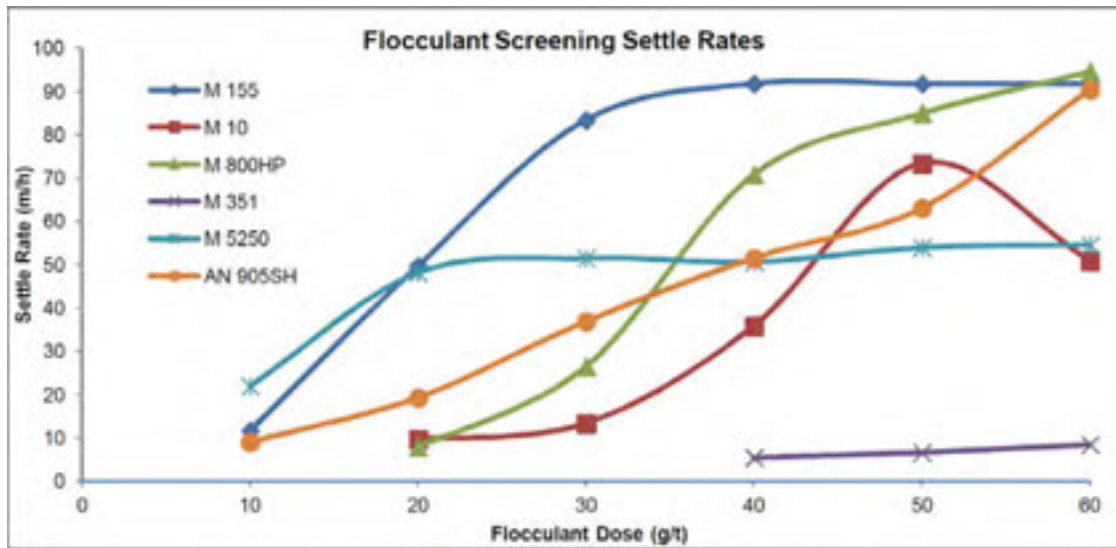
#### 13.1.4 Tailings Thickening Test Work

The objectives of the concentrate thickening test work was to determine:

- Flocculent type and dose.
- Overflow clarity.
- Underflow density and underflow yield stress.

Samples were submitted to Outotec Australia. The scope of work incorporated static cylinder tests for flocculent screening (using a range of flocculants supplied by BASF and SNF), feed dilution tests to establish the optimum feed solids concentration, as well as dynamic thickening work using the General Batch Dynamic Thickening Test Method.

Settling rate test work results are presented in Figure 13-20. The optimum feed solids concentration was established to be 15% solids.



**Figure 13-20: Settling Rates for Yandera Tailings Material Using Various Flocculants**

Flocculent screening work indicated that:

- Magnafloc 5250 produced the fastest settling rate at lower flocculent dosage. However, settling rates did not increase with increased dosage beyond 20g/t.
- Magnafloc 155 produced the fastest settling rates at dosages between 20g/t and 50g/t, but could not produce clear supernatant, even after addition of coagulant.
- Magnafloc 800HP produced the second fastest settling rate at dosages of greater than 40g/t and produced the clearest supernatant. In combination with a coagulant, clarity of the supernatant was significantly improved and very even-shaped flocculants were produced.

It was, therefore, recommended that Magnafloc 800HP, in conjunction with LT425, be used for design purposes to ensure that overflow clarity could be maintained at the required target solids concentration.

Dynamic thickening test work was conducted at flux rates ranging from 0.6 to 1.0t/(m<sup>2</sup>h), and considered reagent dosages from 5 to 15g/t for flocculant and 5 to 10g/t for coagulant. Further test work was conducted to establish the benefits of High Compression Thickening (HCT), and these tests were conducted at a flux of 1.0t/(m<sup>2</sup>h) and 1.2t/(m<sup>2</sup>h). These tests were indicative and required further test work to confirm viability of this process.

The results indicated that typically, flocculant dosages of 5g/t were not appropriate, as these were rarely able to produce an underflow with the solids content in excess of 50% (w/w). A minimum coagulant dosage of 10g/t was required to obtain overflow products with clarity of less than 200ppm.

Based on the above test work, the recommendation was made to use a high rate thickener with a vane feed well. Design parameters for the sizing of concentrate thickening equipment are presented in Table 13-11.



**Table 13-11: Tailings Thickening Design Parameters**

Description	Parameter
Solids loading (t/m <sup>2</sup> /hr)	0.8
Feed slurry density (% w/w solids)	20
Flocculant selection	Magnafloc 800HP
Flocculant dosage (g/t)	10
Coagulant type	LT425
Coagulant dosage (g/t)	10
Underflow density (% w/w solids)	56-58%
Overflow clarity	120ppm

### 13.1.5 Tailing Rheology and Tailings Pumping

Rheology test work was conducted on tailings samples derived from Gremi and Imbruminda by BRASS Engineering in China in 2013.

The outcomes of the study were as follows:

- Viscosities and yield stresses at the proposed underflow solids concentration of 55% to 57% were in the normal range for both Imbruminda and Gremi sample received.
- Settling times were longer than typical copper tailings tested by BRASS previously. The Gremi sample required 70 hours to settle and the Imbruminda sample required 18 hours to settle.
- The settled solids bed was softer than typical copper tailings material tested by BRASS.
  - The penetration weight of the bed was between 7 and 9g for the Gremi Sample, and it was ascertained that pipeline restart would not be problematic with maximum pipeline slope of 15°.
  - Similarly, the tailings sample from Imbruminda had a penetration weight of 8 to 9g and therefore pipeline restart would not be problematic for this sample.
- After 24 hours of settling at a 12° angle, the measure angle of repose was 4° and 3° for Gremi and Imbruminda respectively.
- The stable corrosion rate of the slurry on carbon steel was low for both samples (2.37mm/annum and 1.48mm/annum for Gremi and Imbruminda respectively.). A liner is, therefore, not required.

### 13.1.6 Concentrate Thickening Test work

The objectives of the concentrate thickening test work was to determine:

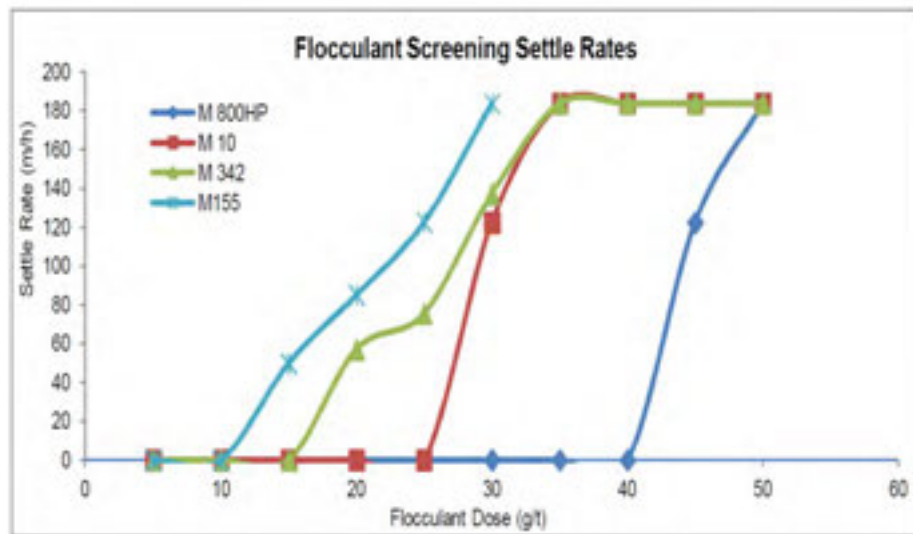
- Flocculent type and dose.
- Overflow clarity.
- Underflow density and underflow yield stress.



Samples were submitted to Outotec Australia. The scope of work incorporated static cylinder tests for flocculent screening (using a range of flocculants supplied by BASF and SNF), feed dilution tests to establish the optimum feed solids concentration, as well as dynamic thickening work using the General Batch Dynamic Thickening Test Method.

It was established that, of the flocculants tested, Magnafloc 155 was the most suited to this application, producing the fastest settling rate at the lowest flocculent dosage, as illustrated in Figure 13-21. This product also produced the clearest supernatant and was, therefore, adopted for used in the dynamic thickening test work.

The optimum feed solids concentration was established to be 20% solids.



**Figure 13-21: Settling Rates for Yandera Cu Concentrate Using Various Flocculants**

It is Outotec’s standard practice to limit flotation product thickener to a maximum solids loading rate of 0.25t/(m<sup>2</sup>/hr). Dynamic thickening test work was conducted at a flux rate of 0.25t/(m<sup>2</sup>.hr) using flocculent dosage rates of 15g/t, 20g/t and 30g/t.

The thickener overflow clarity in each instance was less than the targeted 250-ppm solids, and the following underflow densities could be achieved:

- At a flocculent dosage of 30g/t, an underflow density of 66% was attained with accompanied underflow yield stress (for purpose of sizing the thickener underflow rake drive only) of 128 Pa.
- At a flocculent dosage of 20g/t, an underflow density of 66.3% was attained with accompanied underflow yield stress (for purpose of sizing the thickener underflow rake drive only) of 71 Pa.
- At a flocculent dosage of 15g/t, an underflow density of 66.0% was attained with accompanied underflow yield stress (for purpose of sizing the thickener underflow rake drive only) of 91 Pa.



Based on the above test work, the recommendation was made to use a high-rate thickener with a vane feed well. Design parameters for the sizing of concentrate thickening equipment are presented in Table 13-12.

**Table 13-12 : Concentrate Thickening Design Parameters**

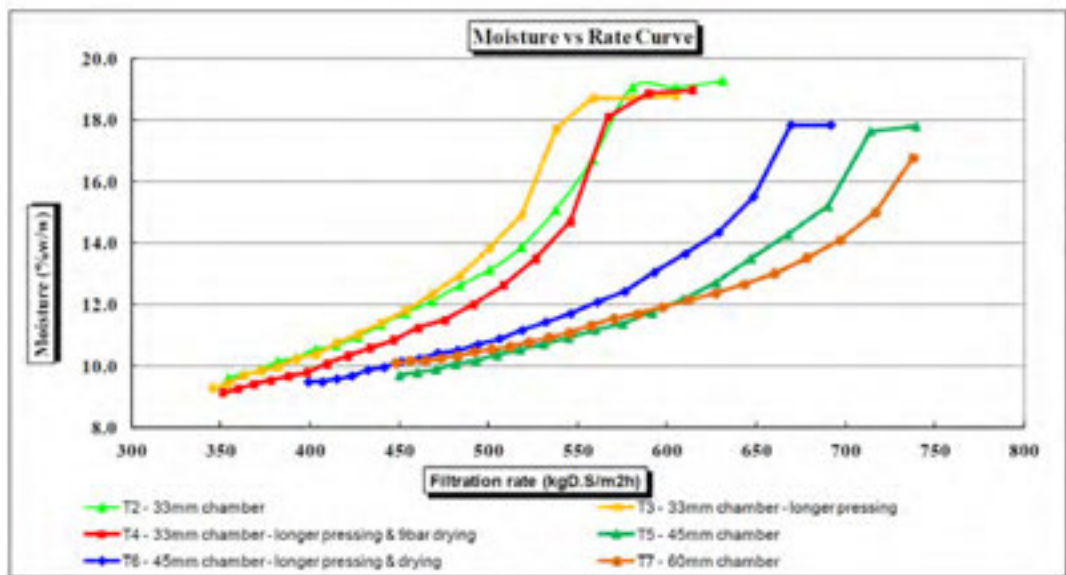
Description	Parameter
Solids loading (t/m <sup>2</sup> .hr)	0.25
Feed slurry density (% w/w solids)	20
Flocculant selection	Magnafloc 155
Flocculant dosage (g/t)	15
Underflow density (% w/w solids)	66-68%
Overflow clarity	<250ppm

### 13.1.7 Concentrate Filtration Test Work

Pressure filtration test work was conducted on a bulk final concentrate sample to establish:

- Moisture content of the filter cake.
- Cake thickness.
- Maximum filtration capacity.

Test work was conducted at Outotec, Australia, using a Labox 100 unit, configured in pressure filtration mode. The test work campaign was targeting a final product moisture content of 9%, and several tests were executed at various operating parameters to establish the filtration rate required to achieve the target moisture content, as presented in Figure 13-22.



**Figure 13-22: Filtration Rates for Yandera Cu Concentrate under Various Conditions**





Based on the above results, it was established that the target final concentrate moisture content of 9% moisture could be attained at a filtration rate of 351kgDS/m<sup>2</sup>h and resulted in a 25mm thick cake. The average drying air consumption was 6l/minute, and the required cycle time was 10.5 minutes.

### 13.1.8 Concentrate Quality – Deleterious and Penalty Elements

The Cu concentrate quality of various locked cycle test work products is presented in Table 13-13.

**Table 13-13: Cu Concentrate Quality (Based on Locked Cycle Products of Two Stage Cleaning Tests)**

Element	Bulk Comp C8-LoM	Gremi Adit Sample	Imbruminda Master Composite
Cu (%)	34.9	41.6	41.8
Mo (%)	0.08	0.04	0.13
Au (ppm)	9.5	12.1	14.1
Fe (%)	24.0	19.5	19.8
S (%)	29.5	26.7	25.8
Ag (ppm)	133.3	86.5	138.5
Mg (%)	0.09	0.12	0.12
Zn (%)	0.69	0.03	0.28
Pb (ppm)	197	1559	273
Sb (ppm)	2.00	0.41	1.40
SiO <sub>2</sub> (%)	4.86	7.66	7.53
Bi (ppm)	83.6	20.0	76.5
W (ppm)	9.77	17.0	5.00
As (ppm)	103.4	44.3	43.1
Hg (ppm)	0.27	0.00	0.05
Cd (ppm)	10	2.50	2.50
U (ppm)	0.25	1.63	0.15

The major deleterious element limits for Cu concentrates entering the market are presented in Table 13-14, and typical limits on penalty elements is presented in Table 13-15.

**Table 13-14: Upper Concentration Limits for Importing Copper Concentrates**

Element	Upper Limit (%)	Yandera Concentrates
Pb (%)	<6.0	Pass
As (%)	<0.5	Pass
F (%)	<0.1	Not tested
Cd (%)	<0.05	Pass
Hg (%)	<0.01	Pass



**Table 13-15: Typical Cu Smelter Penalty Element Schedule**

Element	Penalty Applied for each (%)	Exceeding (%)	Yandera Concentrates
As	0.1	0.2	None
Sb	0.01	0.1	None
Bi	0.01	0.05	None
Cl	0.01	0.05	Not tested
Pb	1.0	1.0	None
Zn	1.0	3.0	None
Ni+Co	0.1	0.5	Not tested
F	10ppm	330ppm	Not tested
Hg	1ppm	10ppm	None

Copper concentrates produced from Yandera are, therefore, appropriate for sale into the market. Future work should include Cl and F analysis to confirm that these elements do not exceed the upper limits for sale.

Molybdenum concentrate analysis is presented in Table 13-16.

**Table 13-16: Mo Concentrate Quality**

Element	Bulk Comp C8-LoM	Gremi Adit Sample	Imbruminda Master Composite
Cu (%)	0.94	3.56	1.37
Mo (%)	51.4	41.6	53
Au (ppm)	2.35	1.68	0.00
Fe (%)	0.75	3.00	0.78
S (%)	34.8	31.7	36.7
Ag(ppm)	29.6	24.7	18.0
Mg (%)	0.15	0.87	0.08
Zn (%)	0.05	0.06	0.06
Pb (ppm)	82	472	137
Sb (ppm)	17.7	7.14	38.1
SiO <sub>2</sub> (%)	3.28	7.17	3.26
Bi (ppm)	13.57	10.9	5.00
W (ppm)	9.47	39.5	16.4
As (ppm)	13.6	30.3	20.0
Hg (ppm)	2.01	3.29	6.06
Cd (ppm)	15	15.0	15.0



### 13.1.9 Concentrate Handling Test Work

A sample of a typical Cu concentrate was submitted to Microanalysis Australia for characterization. The results are presented in Table 13-17.

**Table 13-17: Concentrate Properties**

Description	Measurements
Transportable moisture limit (%)	13.5%
Angle of repose	29.3°
Moisture limit before flow point	14.9%
Moisture limit after flow point	15.0%
Bulk density	1.983t/m <sup>3</sup>
Stow factor	0.504m <sup>3</sup> /t

## 13.2 Basis for Any Assumptions

### 13.2.1 Recovery Estimation Philosophy

Recovery estimates were prepared for an FS executed in 2011, and were based on metallurgical test work conducted by ALS during this time. The test work programme and results are presented in detail in the following test work report:

- Report A13914:- Metallurgical Test work conducted upon Ore Samples from the Yandera Copper-Molybdenum Project for Marengo Mining Limited.

Recoveries were predicted by material type for each of the target zones. The target zones investigated were Gremi, Omora and Imbruminda. The material types investigated were oxide, mixed (transitional) and sulphide (also referred to as hypogene). It is important to note that:

- The 2011 study excluded oxide processing as part of the Project; this has been re-included for consideration (oxide flotation) and is based on test work conducted as part of the 2017 test work campaign.
- The 2011 study estimates did not include Gamagu and so test work conducted as part of the 2017 test work campaign.

### 13.2.2 Copper Recovery Estimate

Copper recovery estimates are based on:

- Oxide material: The recovery estimate is based on average recoveries from test work conducted in a 2017 test work campaign.
- Mixed material: Limited test work conducted on samples of varying S:Cu ratios on Omora and Gremi ore, as well as low-grade global mixed composite test work results.



- Sulphide material: Regression analysis was conducted on the results of cleaner and locked cycle test work campaigns in order to produce correlations between Cu head grade and Cu recovery. Copper recovery to the sulphide zone shows little dependence on Cu head grade with exception of very low grades, and a cap of 95% has been applied to the regression equations. This Cu recovery has been benchmarked against similar deposits.
- Scale-up: A recovery de-rating of 2% has been applied to the calculations to make provision for scaling up from metallurgical test work to full-scale plant operation. The de-rated recovery values should be used for Whittle inputs in all cases.

Recovery predication algorithms are presented in Table 13-18 and Table 13-19. The tables present the recovery projections excluding and including a 2% de-rating for scale up to plant operations.

**Table 13-18: Cu Recovery Prediction Algorithms, excluding the 2% derating for Scale-up**

Ore Type	Target Zone/ Deposit	Recovery Predication (%) Based on Test Work	Source Information
Mixed	Gremi	82%	Mixed ore test work on various Gremi samples refer to tests RDA653 to RDA663 (11 tests). Refer to Table 5.20 in Section 5 of the 30Mtpa Feasibility Study report, as associated rationale
	Omora	58%	Refer to Figure 5.12 and Table 5.21 in Section 5 of the 30Mtpa Feasibility Study report, as associated rationale.
	Imbruminda	75%	Average of single locked cycle test on Imbruminda mixed sample, as well as locked cycle work on global mixed composites. Insufficient information to derive a grade/recovery correlation.
	Dimbi	As per Imbruminda <sup>2</sup>	Assumption
Sulphide	Gremi	$R = 3.3876 * \ln(\text{Cu head grade}) + 99.135$ , capped at 95%	Refer to Figure 5.2, Section 5 of the 30Mtpa Feasibility Study report. Based on cleaner and locked cycle results for three samples
	Omora	$R = 12.766 * \ln(\text{Cu head grade}) + 104.82$ , capped at 95%	Refer to Figure 5.4, Section 5 of the 30Mtpa Feasibility Study report. Based on cleaner and locked cycle results for nine samples
	Imbruminda	$R = 4.3275 * \ln(\text{Cu head grade}) + 96.809$ , capped at 95%	Refer to Figure 5.3, Section 5 of the 30Mtpa Feasibility Study report. Based on cleaner and locked cycle results for nine samples
	Dimbi	As per Imbruminda <sup>1</sup>	Assumption

\* This assumes a concentrate grade of 20%, if a higher grade concentrate (25%) is to be produced, recovery estimates are adjusted to 55%.

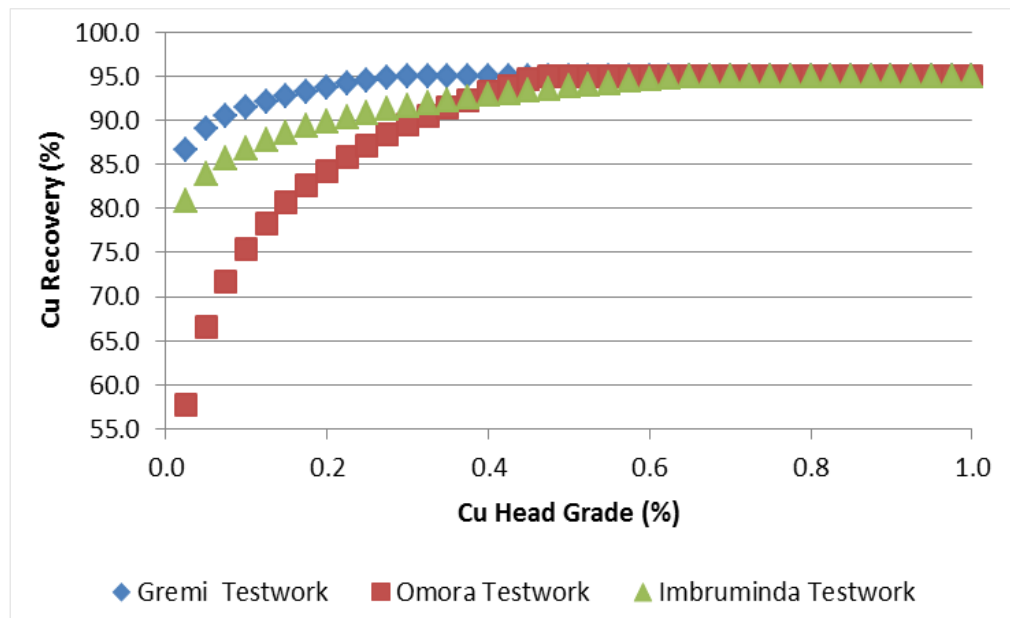
<sup>2</sup> As per recommendation by Nate Chutas, via e-mail, 5 April 2017



**Table 13-19: Cu Recovery Prediction Algorithms, including the 2% derating for Scale-up**

Ore Type	Target Zone/Deposit	Recovery Prediction (%) Based on Test Work
Mixed	Gremi	80%
	Omora	56%
	Imbruminda	73%
	Dimbi	As per Imbruminda <sup>3</sup>
Sulphide	Gremi	$R = 3.3876 \cdot \ln(\text{Cu head grade}) + 97.135$ , capped at 93%
	Omora	$R = 12.766 \cdot \ln(\text{Cu head grade}) + 102.82$ , capped at 93%
	Imbruminda	$R = 4.3275 \cdot \ln(\text{Cu head grade}) + 94.809$ , capped at 93%
	Dimbi	As per Imbruminda <sup>2</sup>

The Cu recovery vs. head grade correlations for sulphide ore are presented in Figure 13-23.



**Figure 13-23: Grade Recovery Correlation for Cu Recovery for Sulphide Ore Type, based on Metallurgical Test Work (excludes de-ration for scale-up)**

### 13.2.3 Gold Recovery Estimate

Gold recovery estimates are based on the results obtained from the variability programme, bulk flotation work on the C1 to C8 composite series as well as locked cycle test work conducted. The data were used to establish correlations between Au recovery and Au head grade. It should be noted that as the final mass pulls to some of the stages were very low, certain of the samples could not undergo Au assay, and the implication of this is that insufficient data was available for recovery by grade predictions for the following materials:

- Oxide ore types (all).

<sup>3</sup> As per recommendation by Nate Chutas, via e-mail, 5 April 2017



- Mixed ore types (all).
- Omora deposit.

It should be noted that flat recovery estimates have been supplied for these deposits using the available information.

Recovery predictions are presented in Table 13-20 and Table 13-21.

**Table 13-20: Au Recovery Prediction Algorithms, excluding the 2% De-rating for Scale-up**

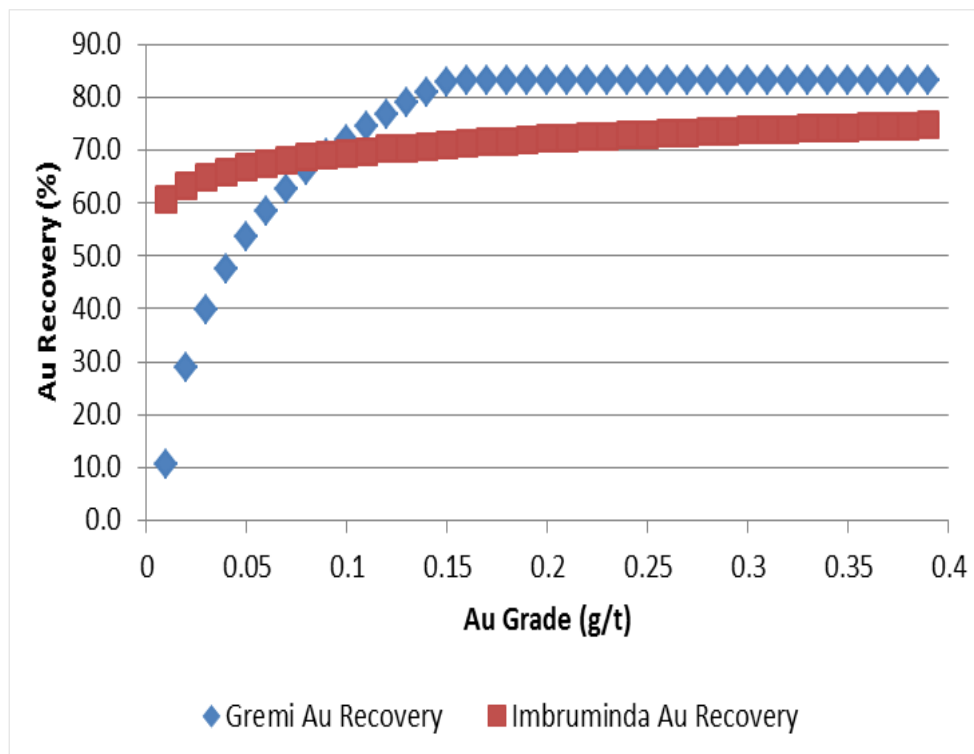
Ore Type	Target Zone/Deposit	Recovery Prediction (%) Based on Test Work	Source Information
Mixed Zone	All zones	70%	Bulk flotation test work on locked cycle testing on a low-grade (0.32% Cu) mixed ore sample (Sample 2B). Refer to test RDA 664. The sample was a global composite.
Sulphide	Gremi	$R = 26.692 \cdot \ln(\text{Au head grade}) + 133.46$ , Au grade < 0.4g/t Capped to a maximum of 83%.	Refer to Figure 5.15, Section 5 of the 30Mtpa Feasibility Study report. Based on cleaner and locked cycle results for five samples
	Omora	64%	Refer to locked cycle test work on a low-grade Omora sample (0.38% Cu), test RDA 596
	Imbruminda	$R = 3.8636 \cdot \ln(\text{Au head grade}) + 78.334$ Capped to a maximum of 83%.	Refer to Figure 5.16, Section 5 of the 30Mtpa Feasibility Study report. Based on cleaner and locked cycle results for seven samples
	Dimbi	As per Imbruminda <sup>4</sup>	Assumption

**Table 13-21: Au Recovery Prediction Algorithms, including the 2% De-rating for Scale-up**

Ore Type	Target Zone/Deposit	Recovery Prediction (%) Based on Test Work
Mixed	Imbruminda	68%
Sulphide	Gremi	$R = 26.692 \cdot \ln(\text{Au head grade}) + 131.46$ , Au grade < 0.4g/t Capped to a maximum of 81%.
	Omora	62%
	Imbruminda	$R = 3.8636 \cdot \ln(\text{Au head grade}) + 76.334$ Capped to a maximum of 81%.
	Dimbi	As per Imbruminda <sup>5</sup>

<sup>4</sup> As per recommendation by Nate Chutas, via e-mail, 5 April 2017

<sup>5</sup> As per recommendation by Nate Chutas, via e-mail, 5 April 2017



**Figure 13-24: Grade Recovery Correlation for Au Recovery for Sulphide Ore Type, based on Metallurgical Test Work (excludes de-ration for scale-up)**

### 13.2.4 Molybdenum Recovery

Molybdenum recovery estimates are limited to a flat estimate because of limited test work data and, as correlation between Mo recovery and Mo head grades was poor, based on the previous test work data. Although variability samples were tested, these were conducted in open circuit and, therefore, are not appropriate for recovery estimation or prediction. The predictions are, therefore, based on the locked cycle test work conducted in 2011/2012.

Recovery predictions are presented in Table 13-22 and Table 13-23.

**Table 13-22: Mo Recovery Prediction Algorithms, excluding the 2% De-rating for Scale-up**

Ore Type	Target Zone/Deposit	Recovery Prediction (%) Based on Test Work	Source Information
Oxide	All zones	57%	Locked cycle test work on a low-grade oxide sample (0.58%Cu). Refer to test RDA594.
Mixed	All zones	71%	Bulk flotation test work on locked cycle testing on a low-grade (0.32% Cu) mixed ore sample (Sample 2B). Refer to test RDA 664. The sample was a global composite.
Sulphide	Gremi	69%	Refer to locked cycle test work on a low-grade Gremi sample (0.38%Cu), test RDA 598





Ore Type	Target Zone/Deposit	Recovery Predication (%) Based on Test Work	Source Information
	Omora	66%	Refer to locked cycle test work on a low-grade Omora sample (0.38%Cu), test RDA 596
	Imbruminda	69%	Refer to locked cycle test work on a low-grade Imbruminda sample (0.32%Cu), test RDA 597
	Dimbi	As per Imbruminda <sup>6</sup>	Assumption

**Table 13-23: Mo Recovery Prediction Algorithms, including the 2% De-rating for Scale-up**

Ore Type	Target Zone/Deposit	Recovery Predication (%) Based on Test Work
Oxide	All zones	55%
Mixed	All zones	69%
Sulphide	Gremi	67%
	Omora	64%
	Imbruminda	67%
	Dimbi	As per Imbruminda <sup>5</sup>

### 13.2.5 Recovery Estimation for Oxide Mineralization

#### 13.2.5.1 Summary and Recommendations

SRK was requested to review the metallurgical work plan and data collected to date supporting the flotation of copper oxide material from the Yandera Project. Era requested SRK to provide an opinion on the potential metallurgical recoveries achievable at industrial scale to support the PFS.

No formal reports were available from any of the three companies involved. The information available to SRK consisted of raw spreadsheets with results as follows:

- A metallurgical flotation testing programme executed in 2017 September that was directed by Advisian, and executed by McClelland Laboratories, a commercial metallurgical testing facility in Nevada, U.S.A.; and
- A mineralogical analysis (QEMSCAN) performed on the tested samples executed in early 2017 October by Bureau Veritas laboratory located in Richmond, British Columbia, Canada.

SRK concluded that the flotation metallurgical testing programme consisting of eight flotation tests using six samples sourced from distinctive diamond drillholes in the Gremi deposit area comprised material modelled as copper oxide from the known resource. This metallurgical testing programme was extremely limited in scope as it trialled a narrow range of reagent additions keeping mostly all other key parameters constant.

<sup>6</sup> As per recommendation by Nate Chutas, via e-mail, 5 April 2017



Unfortunately, but not surprising given the narrow range of tested parameters and the higher complexity of floating mixed ore when compared to sulphides only, the flotation tests reached Cu recoveries ranging from 27% to 53%, which are relatively low recoveries using flotation.

It is SRK's experience that the flotation of oxide minerals is a relatively common practice in every new Cu deposit where the mineralized rock close to surface has been heavily weathered. The presence of oxide and sulphide minerals in varying relative proportions along with the major presence of clay minerals typically translates to industrial scale in Cu recoveries lower than the 90% target. In practice, typical Cu recoveries using flotation on copper oxide material range from 50% up to 70% and incur a higher reagent cost. The sizing of the flotation stage (residence time) is another key element in the engineering phase that sets an upper limit to the ability of industrial operations to achieve higher Cu recovery.

SRK recommends that at this prefeasibility level Era use a conservative value of 55% recovery for the oxide material, and strongly suggests initiating a metallurgical testing programme that will support or further improve that recovery figure.

SRK recommends a testing programme that includes all the fundamental variables: P80, solids concentration, pH, rpm, residence time, redox, multiple reagent options and dosing. SRK estimates that such a programme will total approximately 60 to 80 batch flotation tests plus three locked cycle tests. This metallurgical test work would likely take between three to four months to complete from the time that samples are made available to the laboratory and will cost approximately USD150,000 to USD200,000.

### 13.2.5.2 Metallurgical Test Work Programme Review

The key results from the metallurgical test work programme are presented in Table 13-24. Six different diamond drillholes (DDH) were tested individually, as were composite from all the DDHs. Key observations from the flotation test results are as follows:

- Rougher Cu recovery ranged from 23% to 53.1%.
- The achieved Cu recovery is roughly directly proportional to the portion of Cu associated to sulphide minerals, as illustrated in Figure 13-24.
- Even though from the geological point of view it is representative of the oxide zone, the mineralogical analysis determined that the samples tested have a varying range of Cu oxide/Cu sulphide ratio.
- The information available suggest that Au is associated with the copper sulphides, see Chart
- The association of Au (a credit metal for the concentrates) needs to be understood before attempting to maximize its deportment to the final concentrate stream.
- Rougher concentrate Cu grades were extremely low, ranging from 0.77% to 1.60%, mostly because of the large mass pulls, as illustrated in Figure 13-25. It is highly probable that the liberation size is significantly finer than P80 = 150 µm used for six of the tests, and P80 = 75 µm size used in one test.

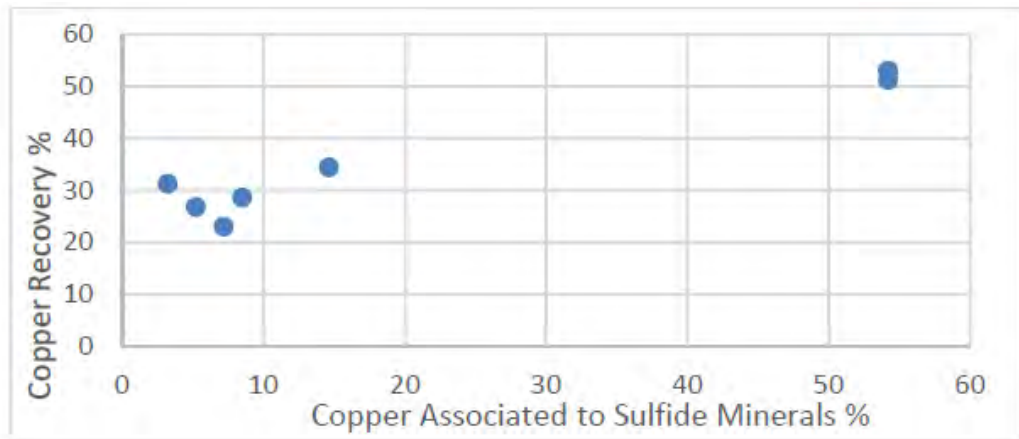


- The rougher concentrate recovery trend, though having slow kinetics as illustrated in Figure 13-25, still showed an upward trend. Combinations of grind size, residence time, and favourable physicochemical conditions have the potential to improve kinetics and overall ultimate Cu recovery.
- The Cu grade in oxide concentrates is typically much lower than that of sulphide concentrates.

**Table 13-24: Yandera – Oxide Flotation Test Work Results**

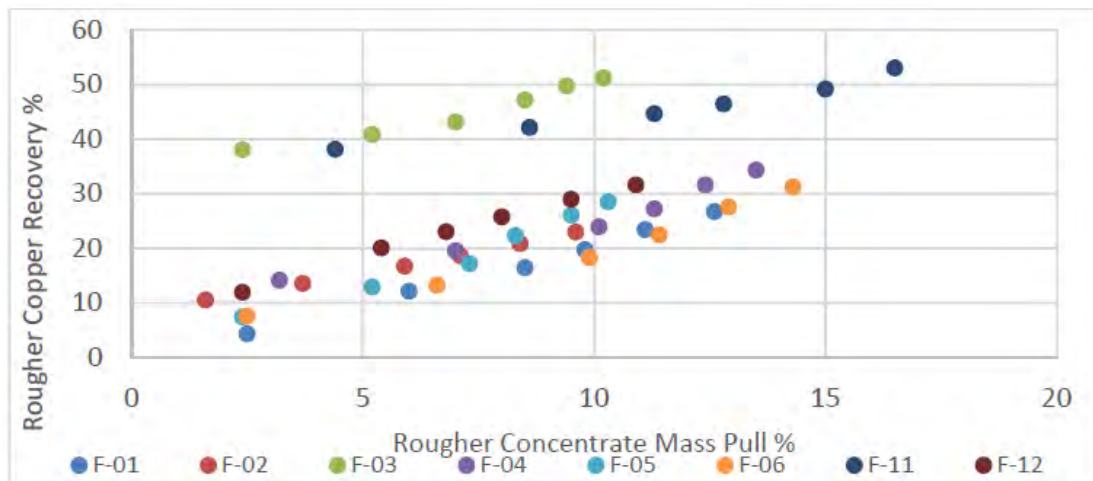
Com- posite	Head Grade Copper %		Flotation Feed Size	Rougher Concen- trate Cu Grade (%)	Rougher Tails Cu Grade (%)	Rougher Copper Recovery (%)	Rougher Gold Recovery (%)	Mineralogy Analysis Copper associated to Sulphide Minerals
	Calcu- lated	Assayed	80% (mm)					
YD346	0.36	0.35	150	0.77	0.30	26.8	16.3	5.2
YD252	0.26	0.25	150	0.62	0.22	23.0	64.9	7.2
YD356	0.32	0.31	150	1.60	0.17	51.3	54.0	54.2
YD517	0.47	0.46	150	1.19	0.35	34.4	48.0	14.6
YD139	0.49	0.47	150	1.35	0.39	28.6	20.0	8.5
YD140	0.46	0.45	150	1.01	0.37	31.3	25.1	3.2
YD356	0.32	0.31	75	1.02	0.18	53.1	n.a.	54.2
Master	0.38	0.39	150	1.11	0.29	31.7	n.a.	n.a.

Source: SRK, 2017



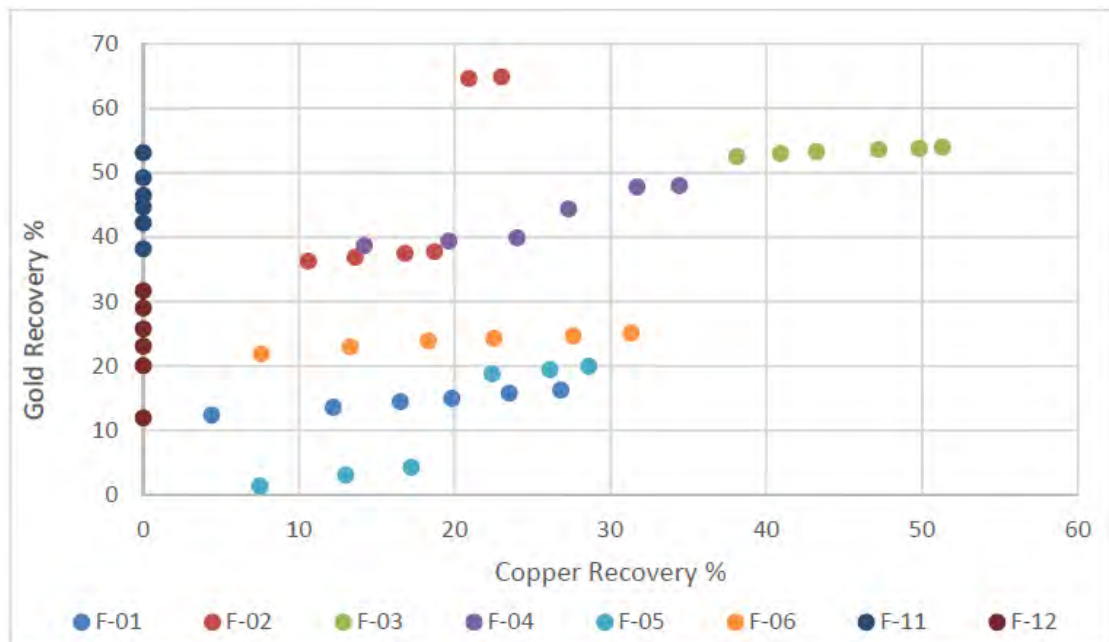
**Figure 13-25: Copper Recovery vs. Percentage Copper associated to Sulphide Minerals**

Source: SRK, 2017



**Figure 13-26: Rougher Copper Recovery vs. Concentrate Mass Pull**

Source: SRK, 2017



**Figure 13-27: Gold Recovery vs. Copper Recovery (Accumulated)**

Source: SRK, 2017

### 13.2.5.3 Recommendations for Further Metallurgical Testing

The outline of the metallurgical testing programme necessary for the Project’s oxide characterization follows:

- Currently, the laboratory has a total of approximately 260kg from the previous testing campaign. A representative sample must be selected from the remaining material to be tested until a set of process conditions are defined. This will satisfy DFS requirements. Additional samples from the site will likely be required to complete variability testing for DFS.



- An initial set of rougher flotation tests that will evaluate a range of particle sizes (at least four sizes); solids density a scale of sulphidization, collectors and pH values should be undertaken. Total estimate of tests is approximately 30. All products should be assayed by sequential Cu, Fe, Au, and SG.
- Results from the above set will be further refined using a combination of batch rougher tests (approximately 20 tests) and rougher kinetic tests (approximately 10 tests). All products should be assayed by sequential Cu, Fe, Au, and SG.
- Results from above three bullet points need to be confirmed at batch level, and then tested in a locked-cycle test in at least duplicate. These tests should be the final confirmation of the metallurgical recovery. The results should be projected to industrial scale.

Developing the metallurgical process to achieve commercial oxide copper recovery is not as straightforward as a conventional sulphide material and, therefore, requires a close, regular interaction between the owner and the testing laboratory. Technical and economic decisions will need to be made at every step of the testing programme by the owner's representative in order to achieve the optimum metal recovery.

#### **13.2.5.4 Recommendations for the Engineering Design Phase**

The key recommendations and comments regarding the sizing of the concentrator unit when processing oxide and mixed ore follow. A suitable metallurgical test work programme should be used to confirm and/or correct them:

- Comminution: mixed ore is typically softer than pure sulphide material. Assuming the crushing and grinding stages were properly sized for sulphide ore, then the current equipment should be suitable to process oxide/mixed ore without any loss in throughput.
- The hydrocyclone classification stage (part of the grinding circuit) will need to be oversized to handle mixed ore. Alternatively, if the current design considers spare units, then the operation with mixed ore will likely make use of all the installed classification capacity. Adding hydrocyclone units to the current installation is likely marginal to negligible additional Capex to the Project.
- The flotation stage needs to consider the slower flotation kinetics from the mixed ore. At this pre-feasibility level, 45 minutes in the rougher-scavenger stage should be considered. Using 500m<sup>3</sup> flotation cells instead of the current 330m<sup>3</sup> will reduce the overall Capex (building, foundation, etc.) and Opex (maintenance) when compared to the current estimates.
- At least one flotation column stage in the last cleaning stage is recommended for the mixed ore (and the sulphide ore). This change should be considered as an improvement in the next phase of the Project.
- Assuming the final tailings thickener was sized for sulphide ore, and then it will likely be subject to upsets when processing mixed ore. A safety factor of 20% in terms of area should be considered. Consistently, the tailings flocculant plant needs to be able to operate at double the normal flocculant addition rate.
- The operating cost, particularly the reagent consumption for the oxide (mixed) ore appears reasonable at this stage.
- Under the current flowsheet design, Au recovery should be estimated at 35%.



### 13.2.5.5 Benchmarking

A benchmarking of Cu concentration projects is provided in Table 13-25 and was provided by SRK (SRK 2017). Most of the projects correspond to actual industrial operations that, in their early operating years, processed a variable proportion of oxides; others correspond to metallurgical testing programmes.

Some of the industrial concentration plants were designed for sulphides only but, because of economics, once operation started, it was decided to blend in oxides/mixed ore with limited results. Other plants had flotation circuits dedicated to process oxide, mixed material, and achieved significantly higher recoveries (OP-01, OP-02, OP-04, OP-05 and OP-09). Yandera could achieve the enhanced level of performance achieved by those projects if the process plant is designed and sized taking in consideration the specific additional requirements of the mixed ore, as described previously in Section 13.2.5.4



**Table 13-25: Benchmark – Oxide Flotation Projects (SRK, 2017)**

Location	Operation	Operation type	Ore type	Copper Mineralogy	Clay presence	Head Grade,	Head Grade,	Head Grade,	P <sub>80</sub>	Flowsheet	Comments	pH	Oxides Recovery %Cu
						%CuT	%Cu Oxide	%Cu Native					
Peru	OP-01	Industrial	Complex mixed ore	a) Oxides: Tenorite, Cuprite, Chrysocolla, Neotacite, Malacite, Azurite b) Native Copper c) Sulfides: Chalcopyrite, Chalcocite, Covellite, Bornite	yes	1.37	0.45	0.35	37% +150#	Flotation	multiple, sequential collectors	8.7	55%
Chile	OP-02	Industrial	Mixed ore	a) Oxides: Atacamite y Chrysocolla c) Sulfides: Chalcocite, Bornite, Chalcopyrite, Covellite	yes	1.15	0.25		50% - 74 µm	Conventional flotation, Oxides Sulfidation, Acid Flotation	multiple, sequential collectors + NaSH		50% - 70%
Chile	OP-03	Industrial	Mixed ore	a) Oxides: Atacamite, Chrysocolla, Malacite, Azurite, c) Sulfides: Bornite, Chalcocite, Covellite, Pyrite	yes					Flotation	multiple, sequential collectors + NaSH. Plant was not designed for oxides. Feed Blending	<9.5	marginal 2%
Chile	OP-04	Industrial, Laboratory	Mixed ore	a) Oxides: Atacamite, Chrysocolla, Malacite, Azurite, c) Sulfides: Chalcopyrite, Chalcocite, Covellite, Pyrite	yes	0.95	0.04		27% +100#	Conventional flotation, Oxides Sulfidation	multiple, sequential collectors	LA 9 Flot. 8	80%
Peru	OP-05	Laboratory	Oxide	a) Oxides: Malacite / Azurite	yes					Flotation	multiple, sequential collectors + NaSH, Na <sub>2</sub> S	11	>80%
Peru	OP-06	Laboratory	Oxide	a) Oxidos: Tenorite / Cuprite	yes					Flotation	multiple collectors		n.a
Mexico	OP-07	Industrial	Oxide	a) Oxidos: (Fe, Cu) HxOx, Cuprite, Chrysocolla	yes	0.38%	0.19%			Flotation	conditioning for sulfides only. Plant was not designed for oxides. Feed Blending		25%
Peru	OP-08	Industrial	Oxides	a) Oxides: Malacite, Azurite	yes					Flotation	multiple, sequential collectors + NaSH, 15% solids in flotation feed. Feed Blending		marginal 2%
Chile	OP-09	Laboratory	Oxide, Mixed	a) Oxides: Atacamite, Chrysocolla, Malacite, Azurite, c) Sulfides: Chalcopyrite, Pyrite	yes		0.20%			Flotation	multiple, sequential collectors + NaSH, 20% solids in flotation feed		30.5% to 60.5%





### 13.2.6 Comminution Samples

Comminution samples were selected from drill cores located in the three main target zones (Omora, Gremi and Imbruminda). Samples used for test work were selected based on lithological nature as well as variation in depth. The locations of the cores used to produce the comminution data set are presented in Figure 13-28 and the distribution of samples within the target zones is presented in Table 13-26.

**Table 13-26: Distribution of Comminution Samples within Target Zones**

Target Zone	# of Cores	Total Samples	Ore Type			
			Hypogene	High Grade	TMO	Oxide
Gremi	11	43	35	5	3	0
Omora	5	14	7	3	4	0
Imbruminda	1	4	4	0	0	0
Dimbi	0	0	0	0	1	0

The quantity of samples tested are deemed to be suitably representative to provide sufficient confidence in the comminution data set used for PFS level design and cost estimates for the sulphide zone. At DFS level, it is proposed to expand upon the current data set for the Imbruminda deposit, as comminution test work in this target zone was limited to a single core. Provision is made for this within the metallurgical forward work plan.

In addition to this, the DFS will present comminution parameters and expand upon current comminution database of comminution samples.

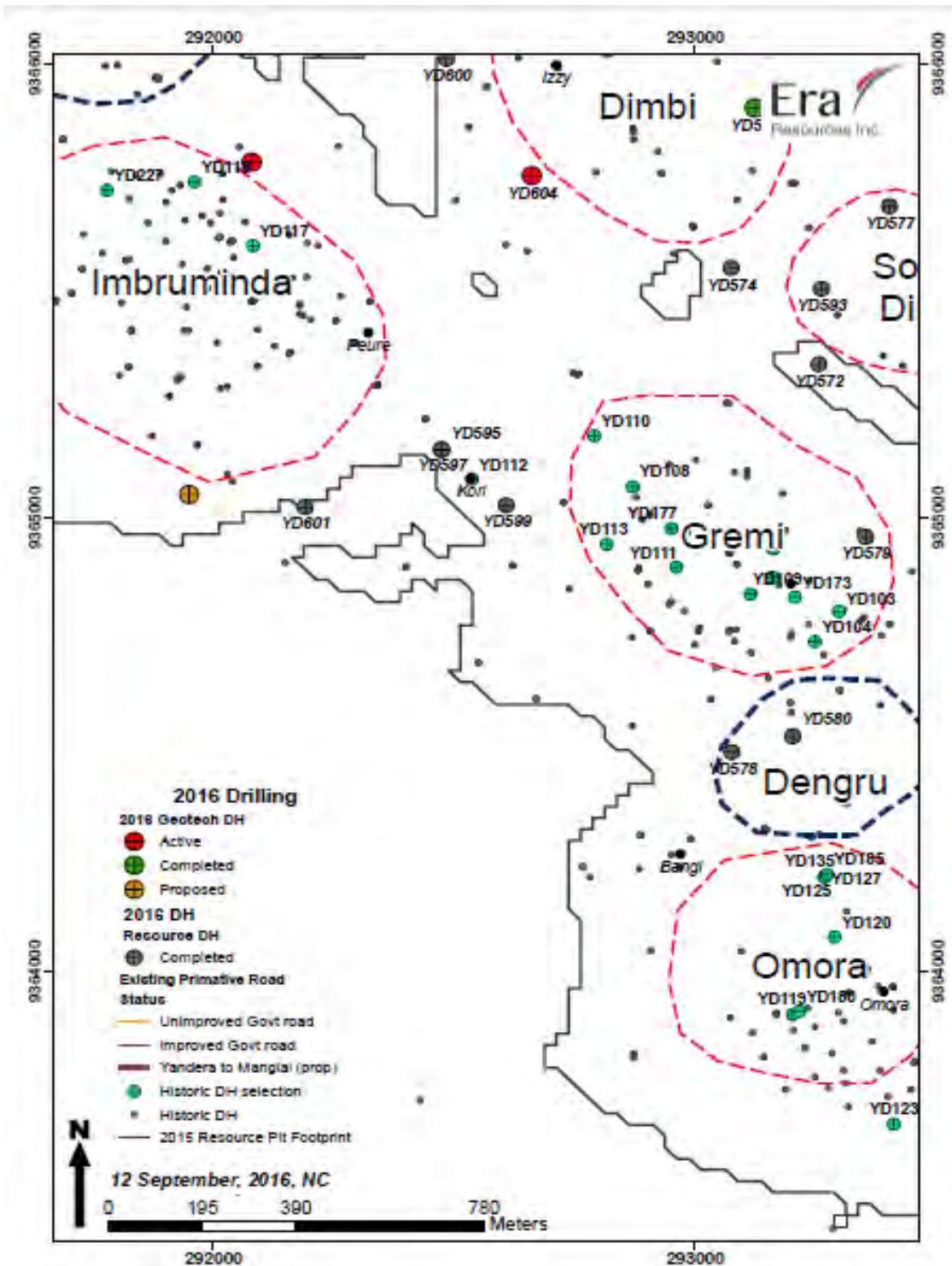


Figure 13-28: Spatial Distribution of Borehole Cores used for Comminution Test Work Programme

### 13.2.7 Flotation and Vendor Bulk Samples

Samples prepared for flotation test work programmes were prepared from numerous drill cores from the various ore bodies. Composites were prepared based on average head grade in each of the target zones and, as such, provide an overall representation of the average composition of each of the target zones. This is an adequate level of understanding of the ore body for a PFS.



However, certain nuances relating to Cu mineralization have been identified as part of the test work campaigns conducted, such as a non-floatable Cu component in the oxide and mixed zones, as well as variability on Cu mineral and pyrite composition. These will have impacts on the potential economic extraction of the revenue metals of this Project. It is, therefore, essential that future work use samples which provide good representation of the composition of plant feed over the LoM plan.

## **13.3 Processing Factors Having Effects on Potential Economic Extraction**

### **13.3.1 Sulphide Ore**

The key metallurgical drivers for economic extraction of Cu from the sulphide ore are variability in Cu mineralogy and pyrite content (as major gangue species). It has been established that the major Cu species in the various target zones comprise predominantly chalcopyrite and bornite in varying proportions, and, along with the pyrite content, this will largely govern the final Cu concentrate grade attainable for a target mass pull. This could range from 40 % to 20 % depending on feed mineralogical composition to the plant.

The metallurgical programme conducted to date has proven that pyrite can successfully be depressed using either NaCN, SMBS or by pH adjustment in the cleaner stages without significant Cu or Mo recoveries. Gold recovery was impacted, possibly because of association with pyrite.

The metallurgical studies conducted to date indicate that a thorough understanding of the Cu mineralogy as well as pyrite distribution across the ore body is essential for prediction of metallurgical performance over LoM.

The distribution of pyrite will dictate the optimal reagent suite. This is one of the major objectives of test work to be conducted as part of the DFS.

Metallurgical test work conducted to date indicates that the recovery of Cu in sulphide form is insensitive to grind and can be conducted using a standard flotation configuration. There is, therefore, little risk that factors such as hardness will affect upon recovery. In addition, the mineralogical composition of the samples tested is typical of porphyry and had demonstrated metallurgical performance similar to other deposits of a similar nature. The risk that mineralogical variation would negative impact upon recovery of Cu is, therefore, deemed low.

### **13.3.2 Oxide and Transitional Ore**

The variable nature of the Cu mineralization within the oxide and mixed zones will influence the economic extraction of Cu from these ore types via flotation. In particular, the presence of non-floatable Cu-bearing mineral species, in the form of clays, silicates and micas, could have an impact on Cu recovery depending on their prevalence in the ore bodies. This phenomenon presented itself during current and historical test work programmes within ores characterized as both oxide and mixed ore.



The distribution of non-floatable Cu-bearing minerals is not clearly understood at present, and it is recommended that particular focus on mineralogical characterization of the oxide and mixed ore zones be a priority during the next phase of study. This will allow for assessment of the extent of this type of mineralization across the four-ore bodies, and allow for more informed estimation of Cu recovery potential as a function on mine plan.

## 13.4 Forward Work Plan

### 13.4.1 Sulphide and Mixed Ore

The objective of DFS test work is to obtain a thorough appreciation of the variability across the ore body and provide confirmation that the proposed process flowsheet is robust enough to cater for variability in the ore body and produce the required target concentrate grades and recoveries.

Key metallurgical drivers for economic recovery of revenue metals from the sulphide zone are Cu mineral species and pyrite distribution in the ore body. The forward work plan will aim to establish how these drivers will influence and impact upon minerals processing in the context of the LoM plan.

New metallurgical drilling will focus on Imbruminda as this is a large contributor to the resource and has limited existing drilling. The balance of samples required for the test work will be sourced from the existing core shed. Close interaction with geology and mining will be required to select samples, which will provide “snap shots” of various periods in the mining operation, and would include samples at various locations, depths and at various head grades.

The additional scope of work will have the following objectives:

- **Further Comminution Studies** – The focus of this work will be on expanding the current data set to include more samples from the Imbruminda and Dimbi ore bodies. Key activities include:
  - Execution of the following test work on additional samples from Imbruminda:
    - Bond Work Indices (BBWi, BRWi, CWi and Ai).
    - SMC testing and drop weight testing.
    - UCS.
  - The existing comminution data set will be grouped according to mining sequence, in order to map hardness and comminution parameters in terms of the LoM plan.
  - The comminution circuit design power modelling will be refined to present the total mill specific energy, SAG mill specific energy and Ball mill specific energy requirements over the LoM.
- **Ore Characterization** – All variability samples will be characterized mineralogically and chemically in order to gain an understanding of how the sulphide ore composition will vary from a mineralogical perspective over the LoM. Activities will include:
  - XRD analysis for establishment of major gangue phases.



- QEMSCAN analysis to establish base metal bulk modal composition, mineral associations, liberation characteristics and grain sizes.
- Chemical analysis.
- **Flotation Characterization** – The objective of this work will be to obtain an appreciation how the variability samples respond to the proposed process flowsheet and conditions. This would allow for mapping of metallurgical performance over the project LoM. The key activities in this section of test work would include:
  - Open circuit cleaner /recleaner rate test work on each variability sample (Cu circuit only).
  - Locked cycle test work on composites representing several periods within the LoM plan.
- **Update Recovery and Concentrate Grade Models** – The current head grade based recovery models will be replaced with recovery models, which will be focussed on modelling how the key metallurgical drivers influence recovery to concentrate and concentrate grades.

### 13.4.2 Oxide Ore

The objective of DFS test work is to obtain a thorough appreciation of the variability across the ore body and provide confirmation that the proposed process flowsheet is robust enough to cater for variability in the ore body and produce the required target concentrate grades and recoveries.

In the case of the oxide ore, understanding of mineralogical variability within this zone will be the most significant outcome of the Project, specifically as the presence of non-floatable Cu may influence the potential to extract Cu economically.

The forward work plan includes:

- **Ore Characterization** – All variability samples will be characterized mineralogically and chemically in order to gain an understanding of how the oxide ore composition will vary from a mineralogical perspective over the LoM. Activities will include:
  - XRD analysis for establishment of major gangue phases.
  - QEMSCAN analysis to establish base metal bulk modal composition, mineral associations, liberation characteristics and grain sizes.
  - Chemical analysis.
- **Comminution Studies** – The focus of this work will be on building an oxide ore data set for comminution circuit design purposes. Key activities include:
  - Execution of the following test work on drill core samples from various locations and depths:
    - Bond Work Indices (BBWi, BRWi, CWi and Ai).
    - SMC testing and drop weight testing.
    - UCS.



- The comminution circuit design power modelling will be refined to present the total mill specific energy, SAG mill specific energy and Ball mill specific energy requirements over the LoM.
- The comminution circuit design power modelling will be refined to present the total mill specific.
- **Flotation Characterization** – The objective of this work will be to establish optimal process conditions for recovery of Cu and Au from the oxide ore zone, and then to obtain an appreciation how the variability samples respond to the proposed process flowsheet and conditions. This would allow for mapping of metallurgical performance over the project LoM. The key activities in this section of test work would include:
  - Rougher optimization test work (Rate tests) to establish appropriate residence time, optimum grind, and optimum feed solids density, optimal reagent suite (collector, CPS conditions, need for addition of viscosity modifiers or depressants).
  - Cleaner optimization test work (cleaner rates and recleaner rates) to establish number of cleaner stages, reagent requirements and residence times for the cleaner circuit.
  - Open circuit cleaner/recleaner rate test work on each variability sample, based on the optimal flowsheet configuration and conditions (Cu circuit only).
  - Locked cycle test work on composites representing several periods within the LoM plan.



## 14 Mineral Resource Estimates

### 14.1 Introduction

The most recent Mineral Resource Estimation for the Yandera deposit was prepared by SRK Consulting as a Technical Report on Resources, with an effective date of May 1, 2015, pursuant to the guidance of the Canadian National Instrument 43-101 – Standards of Disclosure for Mineral Projects National Instrument (NI 43-101). Working closely with the Era staff and consultants in 2016, SRK has constructed a new block model that included independent analysis of the project database, geostatistical analysis of the data, construction of 3D solids with Leapfrog™ modelling software, and estimation of a 3D block model with MineSight® software.

In preparing the current resource statement, SRK has used engineering experience and informed assumptions to define the CoG to reflect the mining and process methods and costs anticipated as the Project advances. This Report provides a mineral resource estimate and a classification of resource reported in accordance with the Canadian Institute of Mining, Metallurgy and Petroleum Definition Standards for Mineral Resources and Mineral Reserves, May 10, 2014 (CIM, 2014). The resource estimate and related geologic modelling were conducted by, or under the supervision of J.B. Pennington, M.Sc., C.P.G., and Justin Smith, B.Sc., P.E., SME-RM, both of SRK Consulting (U.S.), Inc., Reno, Nevada. Mr. Pennington and Mr. Smith are Qualified Persons and are independent of Era for purposes of NI 43-101.

The Mineral Resource estimate was based on a 3D geological model of major structural features and geologically controlled alteration and mineralization. Eleven litho-structural mineral domains were interpreted from mineralized drill intercepts and comprised mostly 3-m core samples. The block size of the model was 25m by 25m by 10m (XYZ). The Project uses metric units. Copper, Mo, and Au were estimated independently into model blocks using Ordinary Kriging (OK). Oxide, non-oxide and transition material types were modelled according to geologic logging and S:Cu ratios characteristic of the three metallurgical material types summarized in Table 14-1. Density was determined from 4,932 samples, which, within the variogram range of the data, were interpolated into the block model using OK. Un-estimated blocks were assigned the average estimated density corresponding to their location within the oxide, transition or non-oxide zones.

### 14.2 Project Coordinates

The coordinate system of the mining part of the Project is AGD66 Zone 55 as established by BHP. Before operations begin, the mining part of the Project would be converted to the gazetted national datum for PNG, PNG94, to generate a local grid with sufficiently low distortion, and to be aligned with the rest of the project infrastructure areas, which are using the PNG94 co-ordinate system.

### 14.3 Drillhole Database

The Project drillhole database consists of 188,045m from 625 drillholes. Most of the drilling done to date is represented by fans of angled holes perpendicular to the main trend of the district (northwest southeast). The holes have intersected mineralization at variable angles producing both true- and apparent-thickness intercepts. Drilling in the resource area is shown in Figure 14-1 highlighting 2016 drill collars.





Drilling techniques included exclusively HQ- and NQ-sized diamond drill core. Samples were collected a one-half core splits using a diamond-bladed saw on 2 to 3 m intervals. Sampling produced an approximate 0.8 kg mass, which was pulverized to produce a charge for fire assay for Au and four acid digestion and multi-element analysis with ICP-AES or ICP-OES for all other elements. Quality control data for the analytical database have been reviewed by the Qualified Person and were deemed acceptable for resource estimation.

## 14.4 Topography

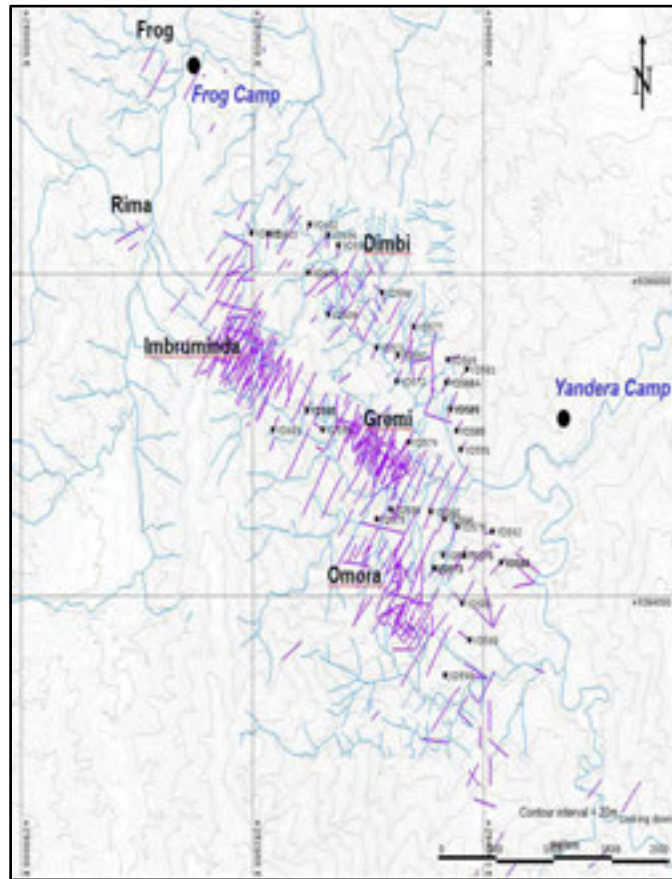
The topographic surface used for this resource report was taken from two sources provided by Era in 2015. The first was a regional survey at a lower precision of 40m contours referred to as the Bundi surface, which is from the 2012 1:100,000 Bundi quad published by the Mineral Resources Authority of PNG (Timm, 2012). The second surface provided by Era was a much higher resolution surface (1m contours) referred to as the LiDAR survey that covered a much smaller area directly over the model area. SRK patched the high-resolution LiDAR surface into the lower resolution Bundi surface, which then served as the basis for SRK's work.

## 14.5 Geological Model

Yandera is a porphyry Cu deposit that, historically, was interpreted as a typical zoned porphyry system, where it was assumed there was a late, barren core surrounded by a concentric pattern of potassic and phyllic alteration. Based on the combined work from SRK and Era for this Report, it became apparent that the deposit is more complex and structurally controlled and the application of the underlying geology would need to be updated to refine the block model.

Yandera is an igneous-hosted, structurally-controlled copper porphyry system comprising a series of adjacent deposits along recognized structural trends. Mineralization is related to multiple pulses of intrusive rock and hydrothermal alteration. Grade has spatial correlation with late dacite intrusions and polymictic breccias with over-printing phyllic alteration.

Within the modelled area, broad tabular zones of Cu mineralization extend from surface to depths of over 500m and have been drill-defined to a strike length of over 5km.



Source: SRK, 2016

**Figure 14-1: Resource Drilling in Model Area, Highlighting 2016 Drill Collars**

In 2016, the Era exploration team, informed by select re-logging of historic drilling and lithology from 43 new drillholes developed 88 50m-spaced northeast-southwest trending geologic cross sections. This main set of cross sections was supplemented by an additional 34 sectional interpretations at Frog and 25 sectional interpretations at Rima. Cross sections were digitized in 2D and used to generate 3D wireframes for block model coding. Sectional interpretations have enhanced the geological understanding of the deposit and formed the basis of the 2016 resource update.

## 14.6 Mineral Domains for Interpolation

SRK re-interpreted the deposit's structural controls and grade trends relative to new 2016 interpreted geology. Five structural domains were established to control the search direction during grade estimation. These structural domains are shown in Figure 14-2.

There is a strong northwest-southeast ( $122-125^\circ$ ) trend to mineralization that corresponds to the strike of the intrusive units. This was identified as the primary search orientation for mineralization in Dimbi, Imbruminda, and Gremi structural domains. There is also a low-angle southeast plunge to much of the mineralization in these domains, which seems to correspond to crackle breccia along the crown or maximum vertical ascent of the nested intrusions. The emplacement of the younger intrusions tends to impart more lateral than vertical continuity in grade and explains the "rootless" geometry of this part of the deposit.



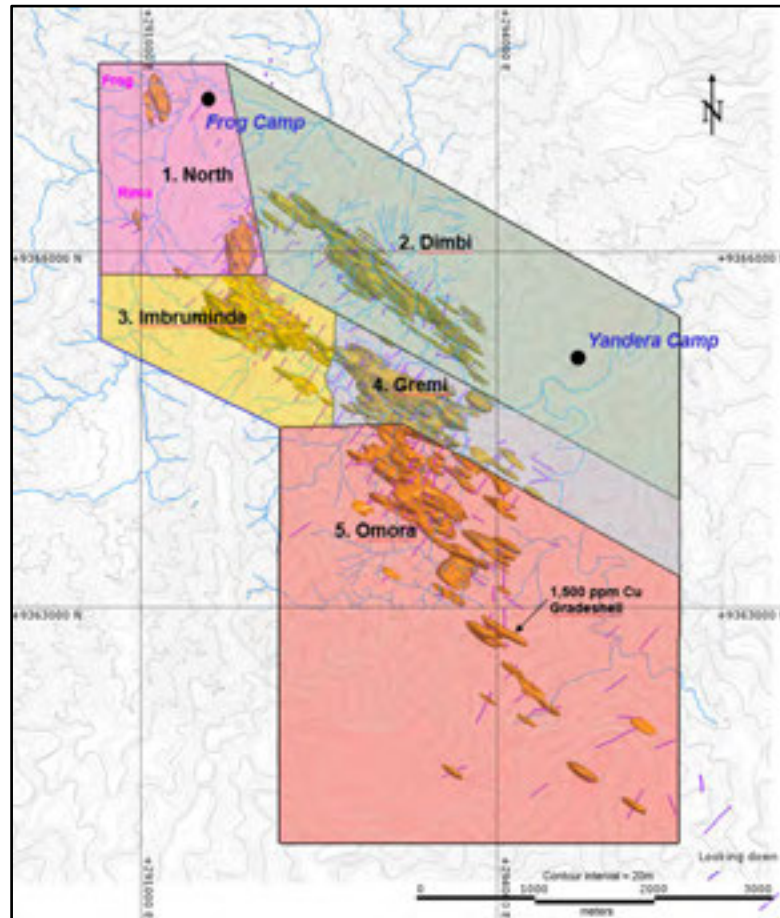
As previously interpreted, Omora mineralization is oriented more southeasterly (~150-155°) and trends steeper following structural intersections and brecciation along intrusive contacts. The strong southeast trend is mirrored in the north domain, which includes the northwest extent of the main zone plus the peripheral deposits at Rima and Frog.

To establish final mineral domains for grade estimation, the structural domains were further subdivided based on lithology. Mineralization is clearly hosted in the breccia unit, in late dacite (PDA) dikes and to a lesser degree the POD stock. Geostatistics of the different lithologies showed a strong grade tenor difference between breccia and PDA (high grade), POD, and HGR (low grade). Therefore, grades in these pairs of rock units, at a minimum, were always estimated separately. Grades were estimated by individual rock units where there was sufficient data.

Eleven mineral domains were developed as a combination of structure, lithology and mineral continuity. Grades were interpolated in 10 of those domains and one, the late, low grade; leucocratic quartz diorite porphyry (PLQ) was set to a fixed grade based on the statistical average grades in that rock unit. The PLQ is interpreted as the last intrusion in the sequence, consisting of a series of thin, tabular north-northeast trending “barren” dikes, which largely cutout grade from older, adjacent mineralized units.

The final constraint on grade estimation was a grade-limiting boundary (grade shell) that was constructed tracking lithologic contacts and honouring the identified structural trends. For the primary metal, Cu, wireframes were constructed around composites using a CoG of 0.15% Cu. This CoG was determined based on early estimates of the project economics. Low-grade intervals that are internal to the overall grade shell were included in the domain to account for internal dilution that would be expected during mining. All resources are reported inside the Cu grade shell, which is shown in Figure 14-2.

For Mo and Au, wireframes were constructed around composites using a cut-off of 25 ppm Mo, and 0.025 ppm Au. These relatively low CoGs were chosen in order to generate wireframes that approximated the volume of the copper grade shells. By insuring that the blocks containing estimated Cu grades were also populated with ancillary metal grades, even at low concentrations, SRK was able to account for the Mo and Au that could potentially be recovered as a by-product during eventual Cu extraction.



Source: SRK, 2015

**Figure 14-2: Yandera Structural Domains and 0.15% Copper Grade Shell**

Detailed geostatistics were analysed using the assay intervals that fell within each of the coded lithologies to determine high-grade capping values. The capped grades were used to generate a new set of fixed 5m length composites. The 5m composites were used in interpolation.

## 14.7 Oxide Model

Metallurgical material types determine ore processing methods and metal recovery. The main goal of oxide modelling was to define a horizon at the top of material suitable for sulphide flotation processing, referred to interchangeably here as non-oxide or hypogene. Oxidized material above the hypogene may be suitable for acid-leach processing, but the current focus is to recover Cu from oxidized material with flotation.

The metallurgical materials defined by recent test work (ARCCON, 2013) are summarized in Table 14-1. Although the empirically determined S:Cu threshold is different in Gremi than in the rest of the deposit, this difference does not result in a significantly different depth to the modelled bottom of oxidation. The S:Cu ratios change by orders of magnitude, and the ratio values change abruptly, rather than gradationally, between material types. Note that the stated Cu recovery for oxide material in Table 14-1 was not used for resource reporting; those recoveries were established using the full body of metallurgical data available.



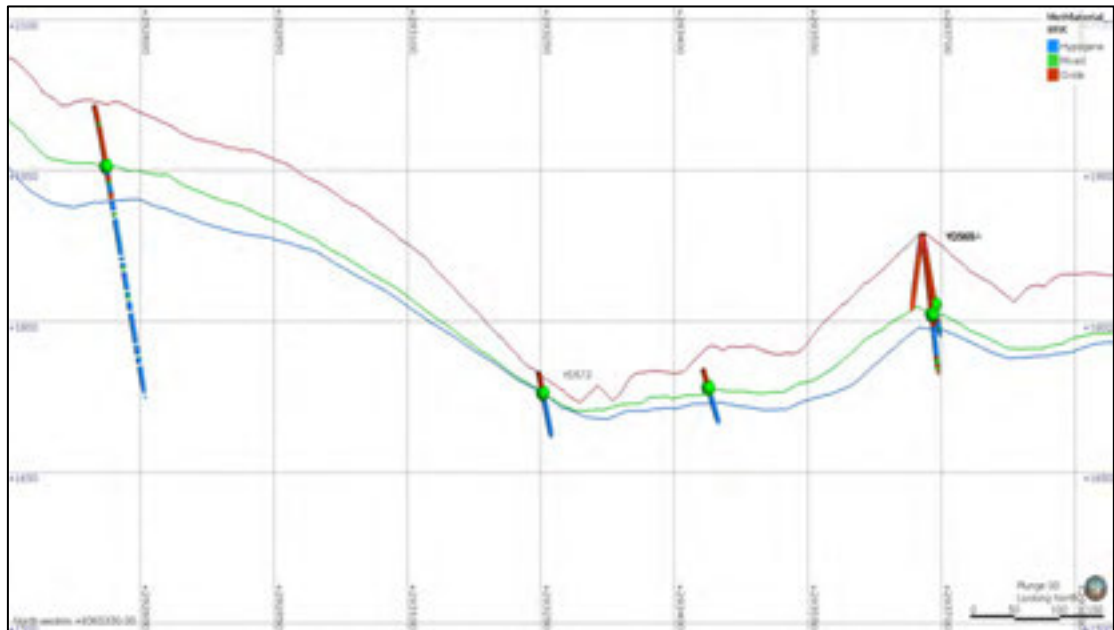
**Table 14-1: Metallurgical Materials and Approximate Copper Recoveries by Flotation**

S:Cu	Material	Recovery of Copper by Flotation
< 0.3	Oxide, Gremi	60% to 65%
< 0.5	Oxide, Others	60% to 65%
0.3 to 0.9	Transition, Gremi	80%
0.5 to 0.9	Transition, Others	80%
>0.9	Non-Oxide, All	>95%

Source: SRK, 2015

Geological logging included visual estimation of oxidation extent but the appearance of the material does not always correlate with the metallurgical material type. Using the calculated S:Cu values and deposit area coding, material types were assigned to sample intervals according to Table 14-1. Only Era drillhole samples have sulphur data, and samples with either sulphur or Cu results below the method detection limit were not assigned a material type. There were 40,130 samples with a material type assigned according to ratio values, and an additional 212 channel samples from Alpha and Bravo Adits at Gremi with assigned material types. Using Leapfrog™ software, contact points between oxide/transition and transition/non-oxide horizons were generated.

This process did not generate single contact points for each drillhole, and additional geological and geochemical interpretation was required to build boundary surfaces. To constrain the oxide boundary in areas without sufficient drillhole data, the interpolation between contact points included an offset from the topographic surface. This approach ensured that the oxidation horizon would be below topography, and did not require extensive digitization. This approach was implemented for the 2015 model, and additional drilling data from 2016 was appended to the existing data set. Generally, new data corroborated nearby data from previous drilling programmes. The additional drilling in the Dimbi deposit area substantially increased the data density there and provided additional constraint on redox boundaries. An example of the resulting modelled metallurgical materials in the Dimbi area is shown in Figure 14-3. Material types in available drillholes are shown and 2016 drillholes are labelled.



Section width 50meters.  
Source: SRK, 2016

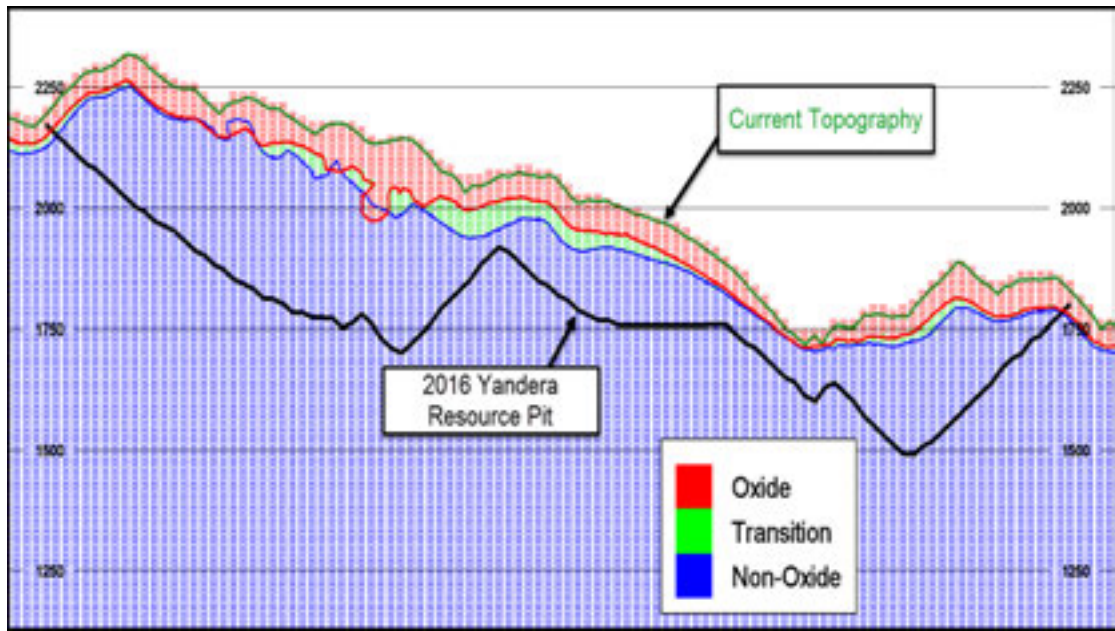
**Figure 14-3: Modelled Oxidation Boundaries with Drillhole Contact points, East-West Section at 9,365,330m North, Dimbi Deposit**

The S:Cu value is a defensible proxy for material type definition in lieu of acid-soluble copper data, especially for oxidized material. Oxidation strongly depletes sulphur in all deposit settings. Therefore, the maximum depth of sulphur depletion is a reliable indicator for the bottom of oxidation. This parameter was used to validate the S:Cu interpretation during modelling and, therefore, the depth of modelled oxidation is unlikely to change significantly with the addition of acid-soluble copper data to the data set.

From test work, copper recovery for transition material is comparable to recovery for hypogene material, and the transition zone is typically less than 20m thick. Therefore, transition material was grouped with hypogene material for resource reporting. For flotation processing, weakly to moderately oxidized material can be blended with hypogene material without detriment to overall copper recovery.

Majority used the modelled oxide and transition boundary surfaces to code the block model. The default code assigned to all blocks was hypogene, and then all blocks with more than 50% volume above the transition boundary were coded as transition material. Next, all blocks with more than 50% volume above the oxide boundary were coded as oxide material. This approach ensured that the bottom of oxide boundary had priority over the other material types, to reflect the limited metal recovery of the material and to honour available data. Topography was coded to blocks as a separate item and was not applied for oxidation coding. The resulting oxide coding in the block model at the same section location as Figure 14-13 is shown in Figure 14-4.





Source: SRK, 2015

**Figure 14-4: Oxidation Coding in 2016 Block Model, East-West Section at 9,365,330m North**

Oxidation extent influences material density. The modelled oxidation zones were used to assign average density values to blocks without interpolated values. The density modelling process is discussed in Section 14.12.

## 14.8 Block Model

The resource block model was informed by 58,214 samples from 568 drillholes at an average drillhole spacing less than 30m in the principal resource areas (Gremi, Imbruminda, and Omora) and less than 100m in other deposits within the model space. Based on this drillhole spacing and anticipated surface mining methods and bench heights, it was decided that a 25m by 25m by 10m (XYZ) block size would be appropriate. The model extents, which include all of the model areas, are listed Table 14-2. The Yandera 3D block model items and definitions for the 2016 SRK resource model are included in Table 14-3.

**Table 14-2: Yandera 3D Block Model Extents**

Coordinate	Minimum (m)	Maximum (m)	Size (m)	No. Blocks
Easting	290,000	296,250	25	250
Northing	9,360,750	9,368,000	25	290
Elevation	700	2,800	10	210
<b>Total No. Blocks</b>				<b>15,255,000</b>

Source: SRK, 2016





**Table 14-3: Yandera 3D Block Model Items**

Item	Item Min	Item Max	No. Decimals	Item Description
TOPO	0	100	1	Percentage of each block below topography
CLASS	0	5	0	Material classification (1=Measured, 2=Indicated, 3=Inferred)
REDOX	0	5	0	Oxidation state for block (1=Oxide, 2=Mixed, 3=Non-Oxide)
SDOM	0	10	0	Structural domain flag
LITH	0	10	0	Lithology domain code
INTDM	0	999	0	Interpolation domain - Combines LITH, SDOM, and CUDOM
SG	0	5	3	Specific gravity - OK interpolation
ESTSG	0	3	0	Flags blocks with estimated SG values
CUEQ	0	10	4	Equivalent copper grade (%)
CUDOM	0	100	0	Copper grade shell flag
CUOK	0	5	4	Copper grade (%) - Estimated with OK
CUNN	0	5	4	Copper grade (%) - Estimated with NN
CUDCL	0	1000	0	Distance to closest composite for Cu OK estimation
CUDAV	0	1000	0	Average distance to composites for Cu OK estimation
CUNCP	0	20	0	Number of composites used for Cu OK estimation
CUNDH	0	10	0	Number of drillholes used for Cu OK estimation
CUPAS	0	5	0	Interpolation pass for Cu OK estimation
MODOM	0	100	0	Molybdenum grade shell flag
MOOK	0	5	4	Molybdenum grade (%) - Estimated with OK
MONN	0	5	4	Molybdenum grade (%) - Estimated with NN
MODCL	0	1000	0	Distance to closest composite for Mo OK estimation
MODAV	0	1000	0	Average distance to composites for Mo OK estimation
MONCP	0	20	0	Number of composites used for Mo OK estimation
MONDH	0	10	0	Number of drillholes used for Mo OK estimation
MOPAS	0	5	0	Interpolation pass for Mo OK estimation
AUDOM	0	100	0	Gold grade shell flag
AUOK	0	4	4	Gold grade (%) - Estimated with OK
AUNN	0	4	4	Gold grade (%) - Estimated with NN
AUDCL	0	1000	0	Distance to closest composite for Au OK estimation
AUDAV	0	1000	0	Average distance to composites for Au OK estimation
AUNCP	0	20	0	Number of composites used for Au OK estimation
AUNDH	0	10	0	Number of drillholes used for Au OK estimation
AUPAS	0	5	0	Interpolation pass for Au OK Estimation



## 14.9 Assay Capping

To prevent extremely high-grade values from over-influencing block grade estimates, the assay grades were capped before compositing within each interpolation domain. To determine the appropriate capping values, log Cumulative Probability Plots (CPPs) were generated for all of the assays by lithological unit. Statistical outliers of the raw assays in each unit were capped. The results of the capping exercise are listed in Table 14-4 to Table 14-6 for each set of mineral domains.

**Table 14-4: Copper Assay Capping Values by Lithological Unit**

Lith Unit	Lith Code	Cu Cap (ppm)
HGR	1	20,000
POD	2	30,000
PDA	3	25,000
BX	4	32,000
PLQ	5	4,000

Source: SRK, 2016

**Table 14-5: Molybdenum Assay Capping Values by Lithological Unit**

Lith Unit	Lith Code	Mo Cap (ppm)
HGR	1	3,000
POD	2	2,900
PDA	3	2,900
BX	4	7,000
PLQ	5	115

Source: SRK, 2016

**Table 14-6: Gold Assay Capping Values by Lithological Unit**

Lith Unit	Lith Code	Au Cap (ppm)
HGR	1	2,000
POD	2	2,800
PDA	3	1,800
BX	4	1,600
PLQ	5	90

Source: SRK, 2016

## 14.10 Compositing

The raw assay database was back-coded with the structural domain and lithology wireframes described in Section 14.6, resulting in 30,640 copper assays within the Cu mineral domain, 33,453 molybdenum assays within the Mo mineral domain, and 32,825 gold assays within the Au mineral domain. The Mo and Au domains had a larger volume than the Cu domain. These coded assays were then composited by lithology domain to a fixed 5m downhole length.



Summary statistics by interpolation domain for each composite file are provided in Table 14-7 to Table 14-9.

The average grades for the PLQ lithology type was calculated globally for each grade item and assigned directly to the model. These PLQ grades, which are well below the cut-off of the deposit, are listed in Table 14-10.

**Table 14-7: Yandera Copper Composite Statistics by CUDOM, SDOM, and LITH**

Estimation Domain <sup>(1)</sup>	Structural Domain	Lithology Domain	No. Intervals	Min (Cu %)	Max (Cu %)	Mean (Cu %)	Co. of Variation
112	1	1 & 2	791	0.005	2.042	0.250	0.76
134	1	3 & 4	163	0.017	1.708	0.274	0.87
212	2	1 & 2	1,554	0.000	3.000	0.316	0.97
234	2	3 & 4	393	0.022	2.413	0.368	0.90
341	3 & 4	1	1,709	0.007	1.463	0.310	0.69
342	3 & 4	2	2,656	0.000	3.000	0.321	0.88
343	3 & 4	3	3,481	0.021	2.500	0.364	0.79
344	3 & 4	4	3,557	0.006	3.200	0.409	0.72
512	5	1 & 2	1,859	0.006	1.940	0.251	0.73
534	5	3 & 4	2,090	0.006	2.812	0.398	0.88

(1) Combination of SDOM and LITH codes where AUDOM = 1 in the Block Model. Stored to INTDM item in Model. Source: SRK 2016

**Table 14-8: Yandera Molybdenum Composite Statistics by MODOM, SDOM, and LITH**

Estimation Domain <sup>(1)</sup>	Structural Domain	Lithology Domain	No. Intervals	Min (Mo %)	Max (Mo %)	Mean (Mo %)	Co. of Variation
112	1	1 & 2	921	0.000	0.145	0.007	1.59
134	1	3 & 4	122	0.000	0.132	0.008	1.94
212	2	1 & 2	2,030	0.000	0.174	0.008	1.76
234	2	3 & 4	450	0.000	0.124	0.009	1.55
341	3 & 4	1	2,085	0.000	0.222	0.010	1.69
342	3 & 4	2	3,323	0.000	0.267	0.011	1.65
343	3 & 4	3	3,990	0.000	0.290	0.011	1.71
344	3 & 4	4	3,646	0.000	0.522	0.016	1.72
512	5	1 & 2	2,156	0.000	0.300	0.006	1.64
534	5	3 & 4	1,845	0.000	0.700	0.021	2.72

Source: SRK, 2016



**Table 14-9: Yandera Gold Composite Statistics by AUDOM, SDOM, and LITH**

Estimation Domain <sup>(1)</sup>	Structural Domain	Lithology Domain	No. Intervals	Min (Au %)	Max (Au %)	Mean (Au %)	Co. of Variation
112	1	1 & 2	1,219	0.001	1.788	0.082	1.50
134	1	3 & 4	221	0.005	0.815	0.082	1.16
212	2	1 & 2	2,252	0.000	1.226	0.065	1.47
234	2	3 & 4	494	0.001	0.560	0.070	1.05
341	3 & 4	1	1,814	0.000	1.505	0.077	1.30
342	3 & 4	2	3,832	0.000	2.752	0.109	1.69
343	3 & 4	3	4,371	0.000	1.564	0.098	1.31
344	3 & 4	4	3,657	0.000	1.139	0.105	1.17
512	5	1 & 2	1,176	0.000	1.476	0.056	2.27
534	5	3 & 4	1,246	0.001	1.240	0.082	1.51

Source: SRK, 2016

**Table 14-10: Average Yandera PLQ Grades (rounded to reflect accuracy)**

Item	Units	Grades
PLQ Cu OK grade	(%)	0.062
PLQ Mo OK grade	(%)	0.010
PLQ Au OK grade	(ppm)	0.001

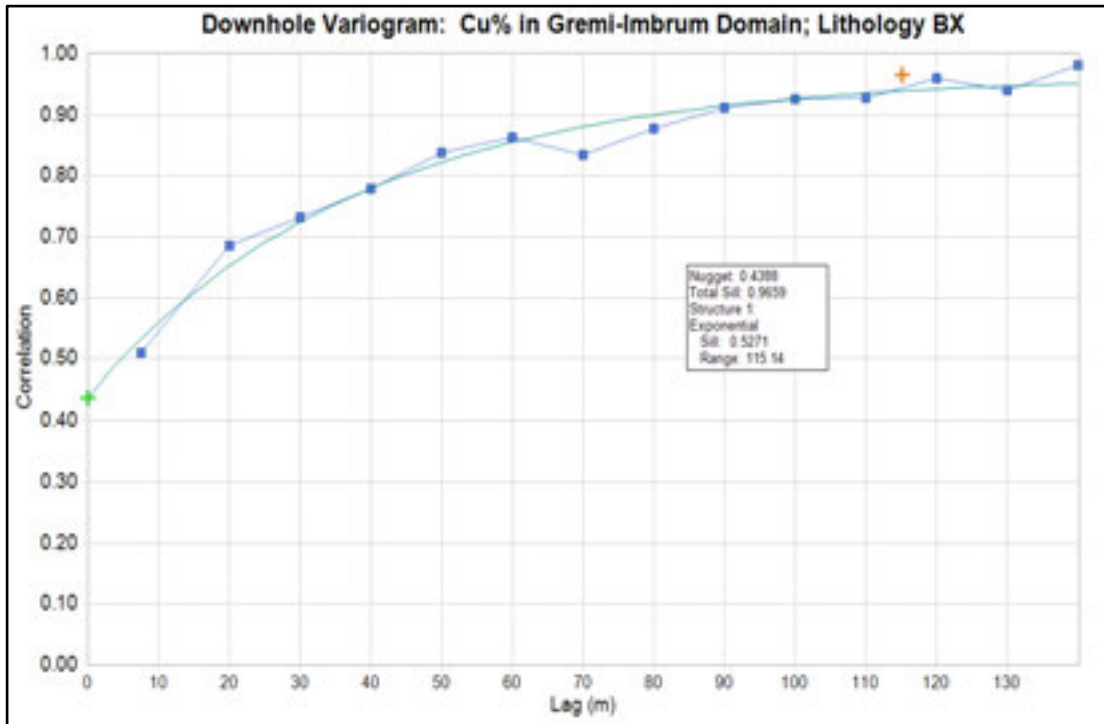
Source: SRK, 2016

## 14.11 Variogram Analysis and Modelling

Variography was carried out on the 5m composites by interpolation domain. To facilitate the work SRK used the MineSight® Data Analysis tool kit to develop a series of correlograms, (semi-variograms where the sill has been normalized to 1.0), for each mineral domain.

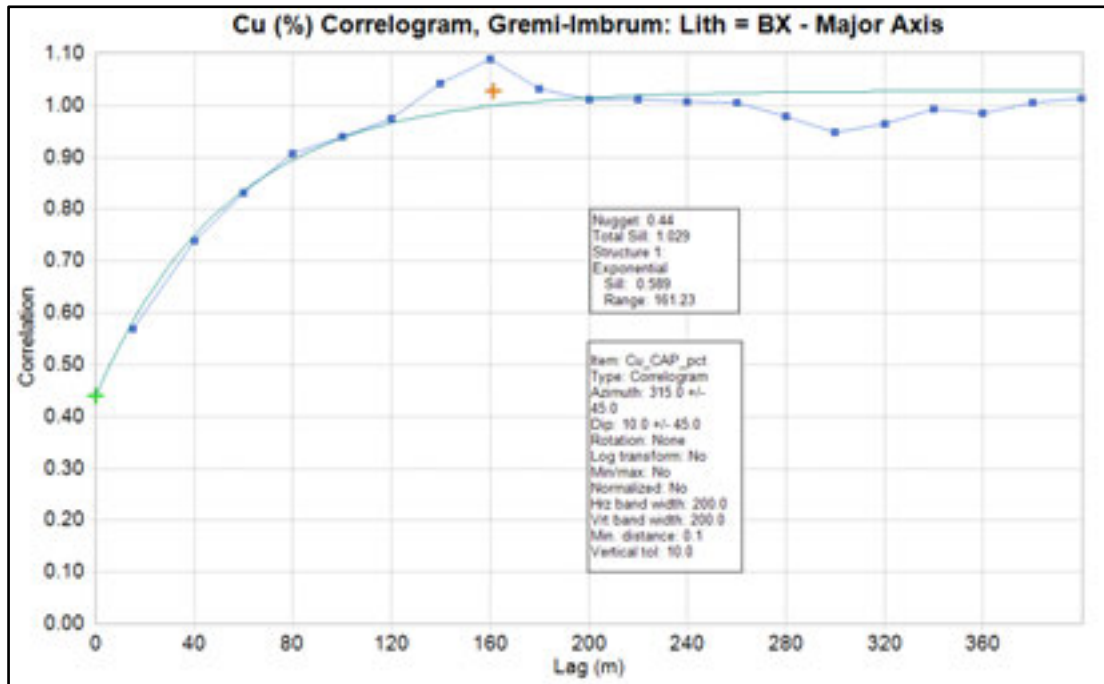
Before developing the 3D correlograms for each mineral domain, the nugget effect was determined by calculating a downhole variogram. The nugget value was then applied to the variogram models.

The variogram for each interpolation domain was controlled fundamentally by a geologic interpretation (lithology, structure, alteration) of that domain. From that original starting orientation, variograms were then adjusted slightly by changing the search directions by a few degrees around each axis to investigate if the initial directions could be improved. Once this work was completed, a final set of directions and search ranges were chosen. The downhole, major, semi-major, and minor direction correlograms for the Breccia lithology, within the Gremi-Imbruminda structural domain, are provided as an example in Figure 14-5 through Figure 14-8.



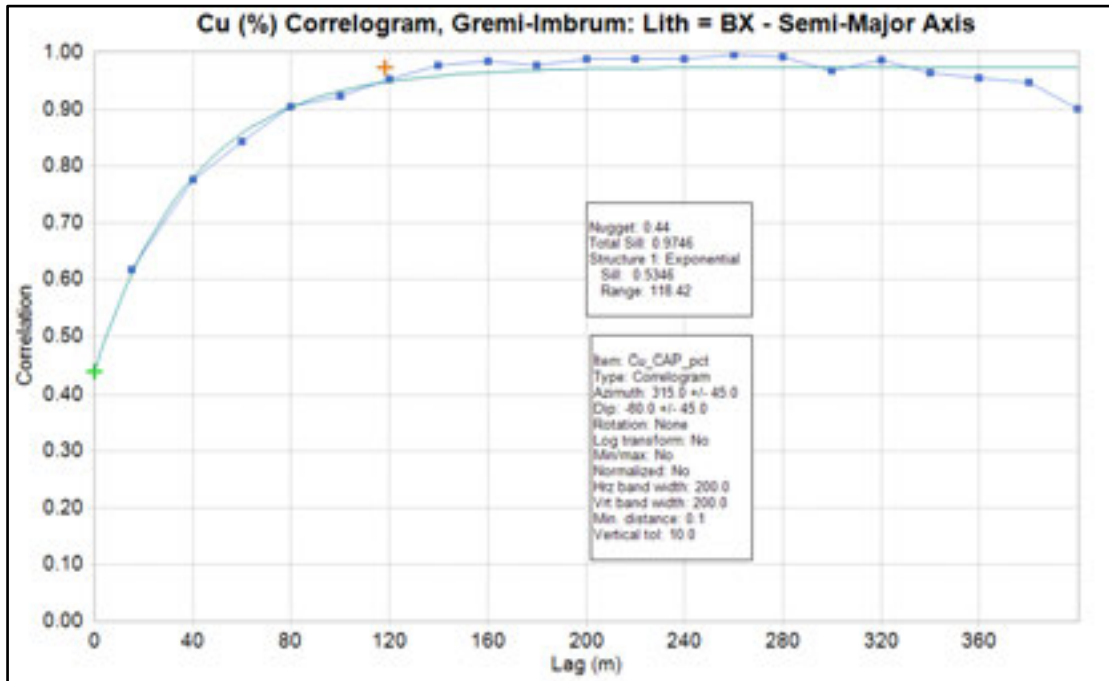
Source: SRK, 2016

Figure 14-5: Copper Downhole Correlogram – Gremi-Imbrum: BX Lithology



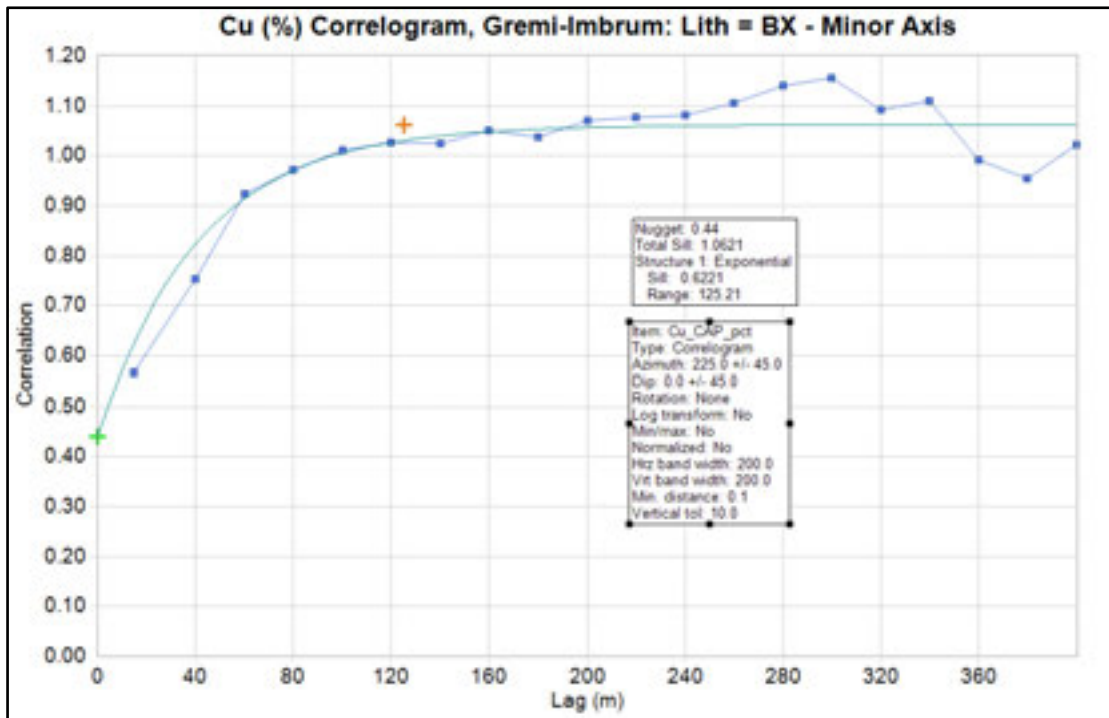
Source: SRK, 2016

Figure 14-6: Copper Correlogram - Major Axis – Gremi-Imbrum: BX Lithology



Source: SRK, 2016

**Figure 14-7: Copper Correlogram – Semi Major Axis – Gremi-Imbrum: BX Lithology**



Source: SRK, 2015

**Figure 14-8: Copper Correlogram – Minor Axis - Gremi-Imbrum: BX Lithology**



The variogram parameters for the copper, molybdenum, and gold interpolation domains are provided in Table 14-10, Table 14-11 and Table 14-12, respectively.

**Table 14-11: Copper Variogram Parameters by Cu Interpolation Domain**

Copper Interpolation Domain	North	North	Dimbi	Dimbi	Grem-Imbrum	Grem-Imbrum	Grem-Imbrum	Grem-Imbrum	Omora	Omora
Lithology	HGR + POD	BX + PDA	HGR + POD	BX + PDA	HGR	POD	PDA	BX	HGR + POD	BX + PDA
Major Axis Range (m)	190	150	180	120	120	120	100	160	80	230
Semi Major Axis Range (m)	155	160	190	60	100	120	90	120	100	100
Minor Axis Range (m)	105	105	60	60	120	75	100	125	100	130
Major Axis Rotation (deg)	345	355	122	132	305	310	310	315	315	155
Semi Major Axis Rotation (deg)	-5	-15	-15	-15	-20	-20	20	10	10	-60
Minor Axis Rotation (deg)	90	90	-75	-80	90	90	90	90	90	-80
Nugget Effect	0.36	0.25	0.5	0.45	0.45	0.31	0.36	0.44	0.33	0.33

Source: SRK, 2016

**Table 14-12: Gold Variogram Parameters by Au Interpolation Domain**

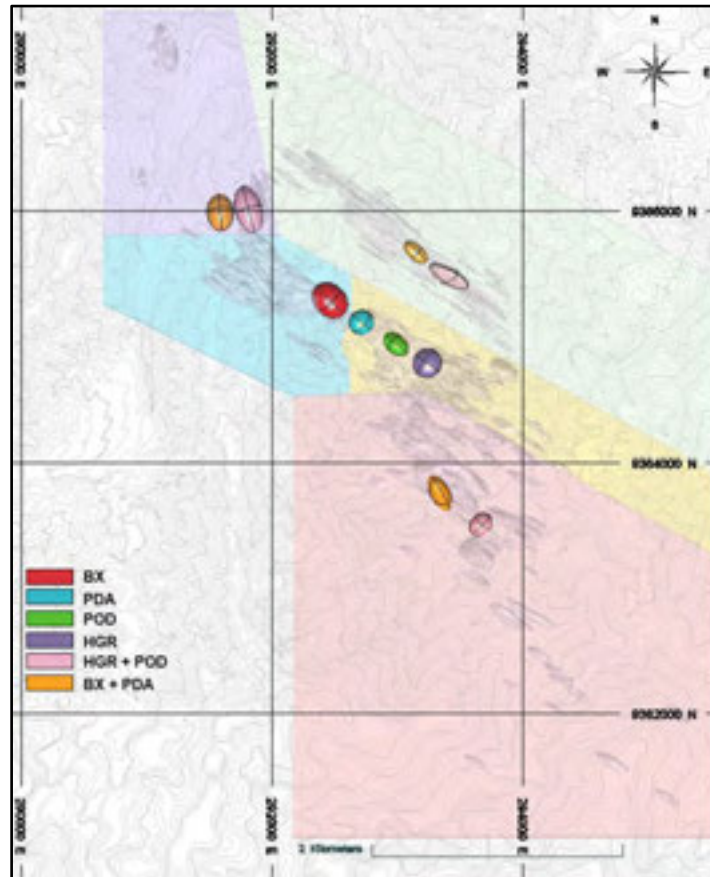
Molybdenum Interpolation Domain	North	North	Dimbi	Dimbi	Grem-Imbrum	Grem-Imbrum	Grem-Imbrum	Grem-Imbrum	Omora	Omora
Lithology	HGR + POD	BX + PDA	HGR + POD	BX + PDA	HGR	POD	PDA	BX	HGR + POD	BX + PDA
Major Axis Range (m)	150	150	100	100	175	175	180	180	120	120
Semi Major Axis Range (m)	155	155	120	120	130	130	180	180	100	100
Minor Axis Range (m)	70	70	120	120	140	140	100	100	60	60
Major Axis Rotation (deg)	355	355	330	330	300	300	330	330	155	155
Semi Major Axis Rotation (deg)	-15	-15	30	30	-20	-20	30	30	-80	-80
Minor Axis Rotation (deg)	90	90	90	90	90	90	90	90	90	90
Nugget Effect	0.55	0.55	0.48	0.48	0.55	0.55	0.6	0.6	0.35	0.35

Source: SRK, 2016





As a reference, Figure 14-9 has been included to show the copper variogram search ellipses defined in Table 14-12 relative to their corresponding lithology groupings



Source: SRK, 2016

**Figure 14-9: Figure 14 9: Copper Search Ellipses Relative to Lithology Groupings**

## 14.12 Grade Estimation

Copper, molybdenum, and gold grades were estimated using a three pass OK method within each estimation domain. Grade estimation was repeated using polygonal methods (Nearest Neighbour (NN)) to facilitate model validation. The SRK polygonal method used one composite to estimate each block and applied anisotropy that approximated the directional distance weighting used in the OK estimate.

The first pass was limited to data very close to the composites at approximately one half of the variogram range and required at least four composites from a minimum of two holes. This distance factor was adjusted until the SRK QP was satisfied that the blocks estimated in the first pass represented an appropriate volume given the density of the source data. This short first pass ensures that blocks close to composite data have grades consistent with the composite data.



The second interpolation pass was limited to data within the full variogram range and required at least three composites from two drillholes. This distance factor was adjusted until the estimated blocks filled a volume appropriate given the density of the source data.

The third pass was given a large search radius and a minimum of one composite from one drillhole to ensure that all blocks within the interpolation domain were estimated.

The key interpolation parameters for the copper OK estimate are shown in Table 14-13 below.

**Table 14-13: Ordinary Kriging Interpolation Parameters for the Yandera Copper Estimation**

Interpolation Domain	112			134			212			234			341			342			343			344			512			534		
	Short	Med	Long	Short	Med	Long	Short	Med	Long	Short	Med	Long	Short	Med	Long	Short	Med	Long	Short	Med	Long	Short	Med	Long	Short	Med	Long	Short	Med	Long
<b>Search Parameters</b>																														
Rotation - Major	345	345	345	355	355	355	122	122	122	132	132	132	305	305	305	310	310	310	310	310	310	315	315	315	315	315	315	155	155	155
Rotation - Semi Major	-5	-5	-5	-15	-15	-15	-15	-15	-15	-15	-15	-15	-20	-20	-20	-20	-20	-20	20	20	20	10	10	10	10	10	10	-60	-60	-60
Rotation - Minor	90	90	90	90	90	90	-75	-75	-75	-80	-80	-80	90	90	90	90	90	90	90	90	90	90	90	90	90	90	-80	-80	-80	
Search Range Factor	1.00	1.00	5.00	0.50	1.00	5.00	0.75	1.00	5.00	0.50	1.00	5.00	0.50	1.00	5.00	0.50	1.00	5.00	0.50	1.00	5.00	0.75	1.00	5.00	0.50	1.00	5.00	0.75	1.00	5.00
Ellipse Major Search Range	190	190	950	75	150	750	135	180	900	60	120	600	60	120	600	60	120	600	50	100	500	120	160	800	40	80	400	173	230	1150
Ellipse Semi-Major Search Range	155	155	775	80	160	800	143	190	950	30	60	300	50	100	500	60	120	600	45	90	450	90	120	600	50	100	500	75	100	500
Ellipse Minor Search Range	105	105	525	53	105	525	45	60	300	30	60	300	60	120	600	38	75	375	50	100	500	94	125	625	50	100	500	98	130	650
Min No. Comps to Estimate	4	3	1	4	3	1	4	3	1	4	3	1	4	3	1	4	3	1	4	3	1	4	3	1	4	3	1	4	3	1
Max No. Comps to Estimate	15	15	15	15	15	15	15	15	15	15	15	15	15	15	15	15	15	15	15	15	15	15	15	15	15	15	15	15	15	15
Max No. Comps per Hole	3	2	2	3	2	2	3	2	2	3	2	2	3	2	2	3	2	2	3	2	2	3	2	2	3	2	2	3	2	2
<b>Split Octant Declustering</b>																														
Max# Composites per Oct/Quad	3	3	2	3	3	2	3	3	2	3	3	2	3	3	2	3	3	2	3	3	2	3	3	2	3	3	2	3	3	2
Max# Adjacent Empty Oct/Quad	8	10	15	8	10	15	8	10	15	8	10	15	8	10	15	8	10	15	8	10	15	8	10	15	8	10	15	8	10	15
<b>Correlogram Parameters</b>																														
Correlogram Range - Major	190	190	190	150	150	150	180	180	180	120	120	120	120	120	120	120	120	120	100	100	100	160	160	160	80	80	80	230	230	230
Correlogram Range - Semi Major	155	155	155	160	160	160	190	190	190	60	60	60	100	100	100	120	120	120	90	90	90	120	120	120	100	100	100	100	100	100

Interpolation Domain	112			134			212			234			341			342			343			344			512			534		
Interpolation Pass	Short	Med	Long	Short	Med	Long	Short	Med	Long	Short	Med	Long	Short	Med	Long	Short	Med	Long	Short	Med	Long	Short	Med	Long	Short	Med	Long	Short	Med	Long
Correlogram Range Minor	105	105	105	105	105	105	60	60	60	60	60	60	120	120	120	75	75	75	100	100	100	125	125	125	100	100	100	130	130	130
Correlogram Model Type	Exp	Exp	Exp	Exp	Exp	Exp	Exp	Exp	Exp	Exp	Exp	Exp	Exp	Exp	Exp	Exp	Exp	Exp	Exp	Exp	Exp	Exp	Exp	Exp	Exp	Exp	Exp	Exp	Exp	Exp
Nugget Effect	0.36	0.36	0.36	0.25	0.25	0.25	0.5	0.5	0.5	0.45	0.45	0.45	0.45	0.45	0.45	0.31	0.31	0.31	0.36	0.36	0.36	0.44	0.44	0.44	0.33	0.33	0.33	0.33	0.33	0.33

A positive distance of influence means an outlier composite is not used beyond the distance of influence. A negative value means an outlier grade is capped to the CoG beyond the distance of influence. No outliers were used for copper interpolation, but were used for other metals.  
Source: SRK, 2015

SRK applied outlier restrictions to each interpolation run. These outlier restrictions limit the composites distance of influence above a specified grade and can either make those composites invisible to blocks beyond a certain distance, or cap those values to a lower grade beyond a given distance. These outlier restrictions were adjusted for each run until the resulting grades validated both visually and statistically.



## 14.13 Density Modelling

Following Era’s 2012 exploration drilling programme and into the 2016 programme, a high priority was placed on density sampling. This density-sampling programme increased the original data set from approximately 200 samples to one that now contains 4,932 density measurements. The new sampling is well distributed within the modelled volume of rock and facilitated interpolation of density rather than a simple assignment by material type.

Due to the relatively low variance, spacing and quantity of the density samples, SRK conducted variography on all of the density samples to determine appropriate search distances for density interpolation. Once the ranges were determined, SRK used the major controlling structures within each model area to develop the rotation angles to be used for interpolation in those domains. Using the variogram parameters listed in Table 14-14, a single pass OK interpolation was completed within each model area.

**Table 14-14: Density Variogram Parameters by Model Area**

Model Area	1. North	2. Dimbi	3. Imbruminda	4. Gremi	5. Omora
Major Axis Rotation	15	127	135	120	90
Semi Major Axis Rotation	-15	-10	-5	-20	-10
Minor Axis Rotation	0	0	0	0	0
Major Search Distance	210	210	210	210	210
Semi Major Axis Range	190	190	190	190	190
Minor Axis Range	60	60	60	60	60
Nugget Effect	0.2	0.2	0.2	0.2	0.2

Source: SRK, 2016

Approximately 87% of the model ore blocks (above and below cut-off) inside the resource pit shape were interpolated from density data measured in drill core. The remaining 13% were assigned based on oxidation material type using the mean values listed in Table 14-15.

**Table 14-15: Full Model Summary Statistics for SG by Level of Oxidation**

Level of Oxidation	No. Blocks	Minimum	Maximum	Mean
Oxide	51,685	1.74	3.27	2.51
Transition	16,561	1.98	3.47	2.57
Hypogene	361,258	2.03	3.82	2.63
All	429,504	1.74	3.82	2.61

Source: SRK, 2016

## 14.14 Model Validation

Various measures were implemented to validate the Yandera resource block model. These measures included the following:

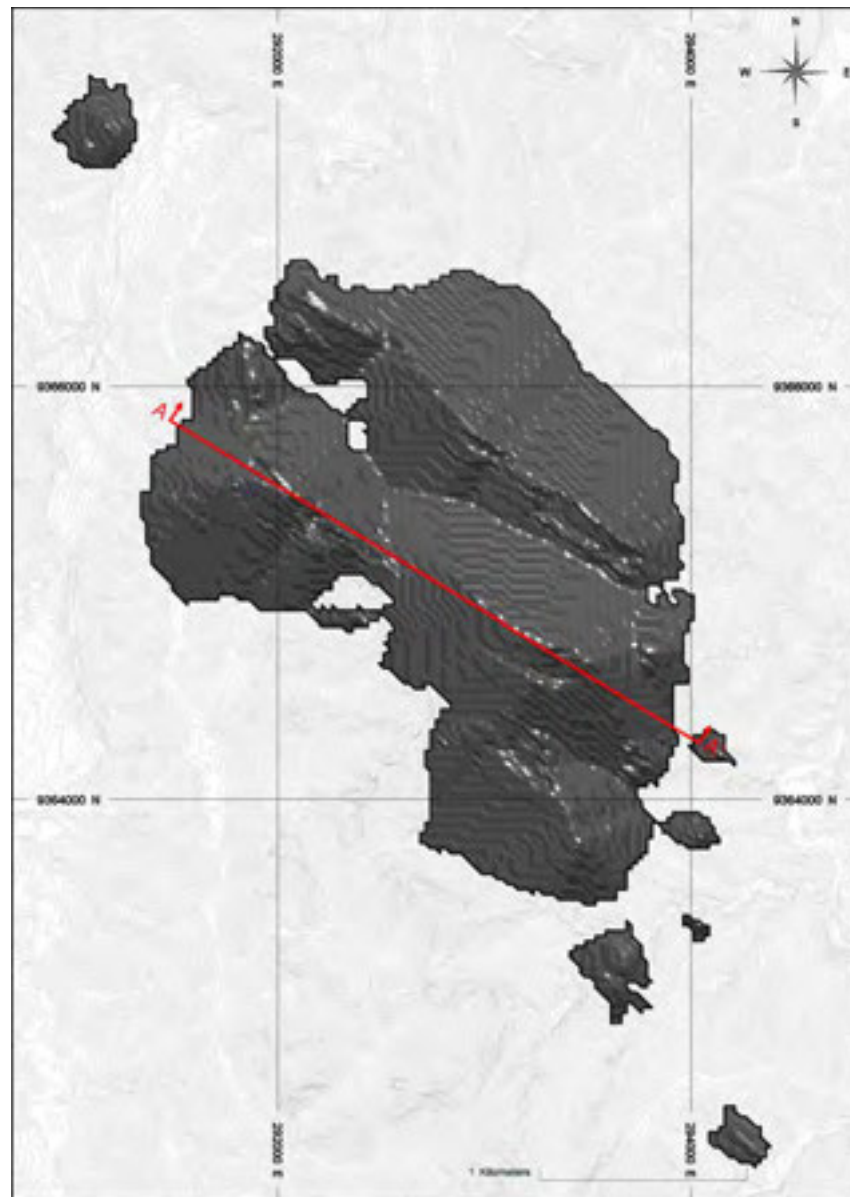
- comparison of drillhole composites with resource block grade estimates from all zones visually in section;



- statistical comparisons between block and composite data using distribution analyses;
- statistical comparisons between the OK and NN models; and
- Swath plot analysis (drift analysis) comparing the inverse distance model with the NN model and composite grades.

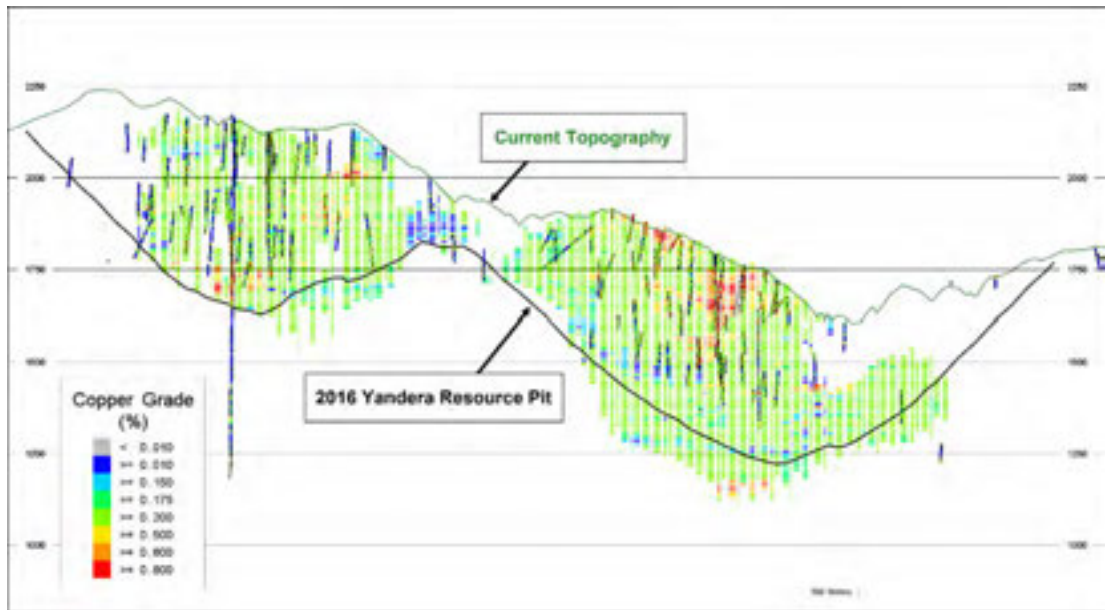
### 14.14.1 Visual Comparison

Visual comparisons between the block grades and underlying composite grades in section show close agreement. A sectional view through both the Gremi and Imbruminda model areas displaying both block and drillhole composite grades is provided in Figure 14-10 while Figure 14-11 provides a plan view showing the location of this longitudinal section.



Source: SRK, 2016

**Figure 14-10: Visual Grade Validation – Plan View**

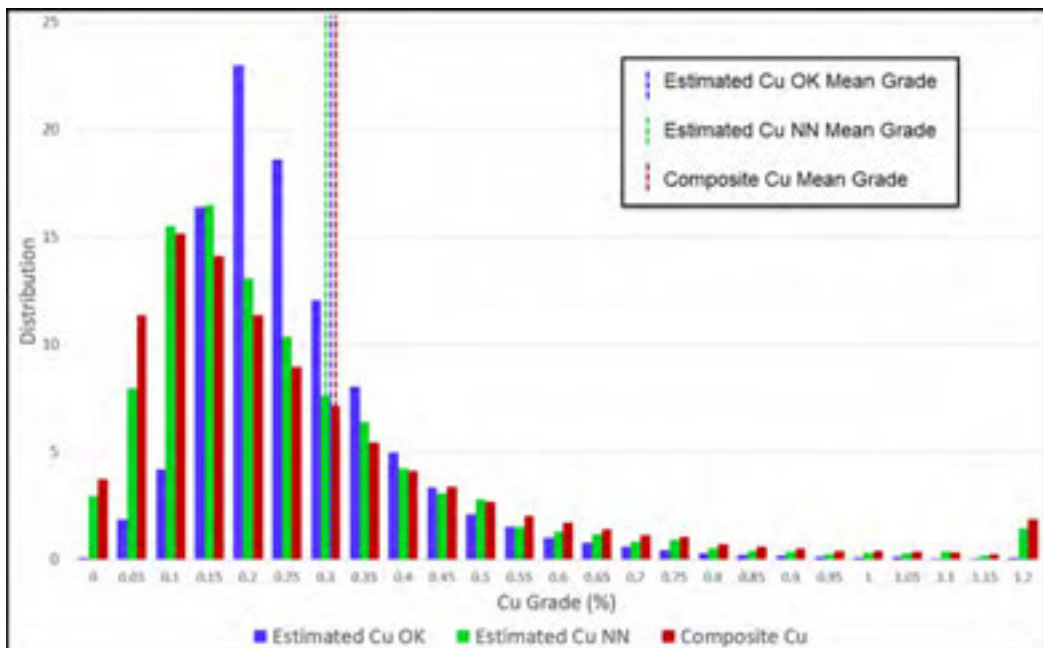


Source: SRK, 2016

**Figure 14-11: Visual Grade Validation – Longitudinal Section View**

### 14.14.2 Comparative Statistics

SRK conducted statistical comparisons between the OK blocks contained within mineral domains and their underlying composite grades. A histogram comparing block and composite copper grades is provided in Figure 14-12. The comparison shows that the model OK grade distribution for copper is appropriately smoothed towards the mean grades when compared with the underlying composite or NN distributions. The pull of the OK grades away from zero are expected as the grade shell constraining the interpolation was built around 0.15% Cu grades.



Source: SRK, 2016

**Figure 14-12: Model Validation - Modelled Cu OK vs. Cu NN vs. Composite Cu CAP**



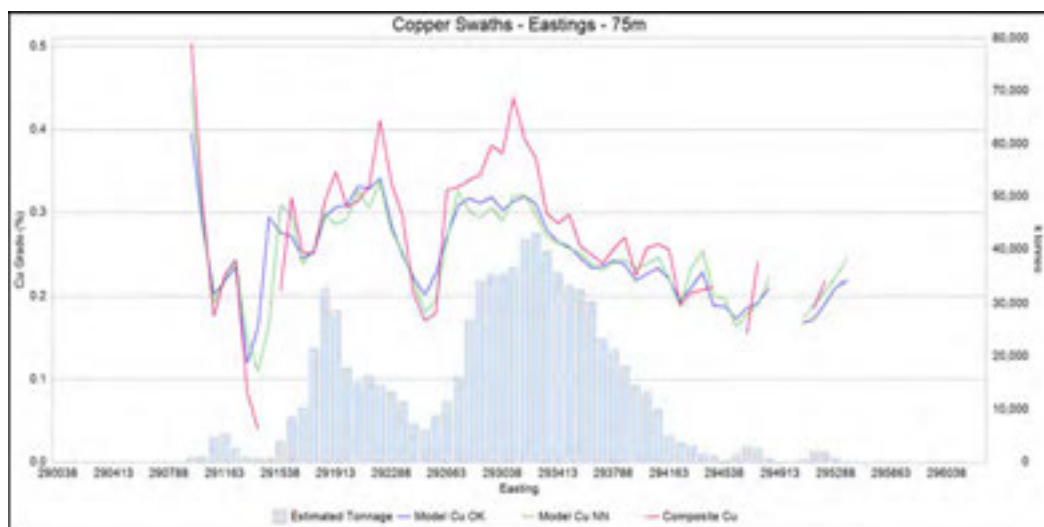


SRK ran additional statistics by interpolation domain for each model element comparing the Cu NN and Cu OK grades. The NN interpolation method provides a declustered representation of the sample grades and, therefore, the resulting mean grades of any other method should be similar to the mean grade of the NN estimate at a zero CoG. To ensure that the OK estimate was close to the NN estimate, SRK adjusted the search criteria pass by pass in the interpolation until the estimated OK mean was within acceptable tolerances of the NN mean, approximately  $\pm 5\%$ . The global mean copper OK grade was 0.8% more than the NN estimate. For molybdenum, the global mean OK grade was 3.6% less than the NN estimate. For gold, the global mean OK grade was 1.5% less than the NN estimate.

### 14.14.3 Swath Plots

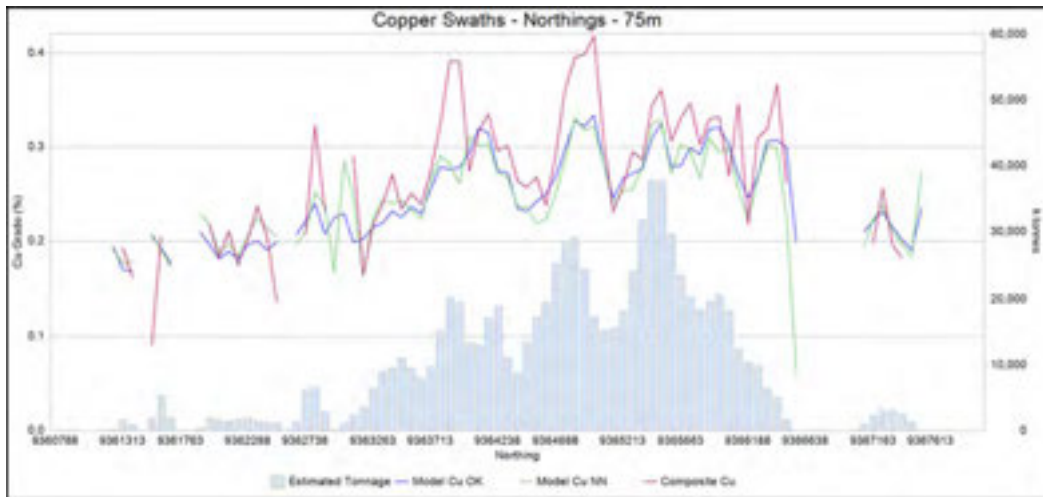
A swath plot is a graphical display of the grade distribution derived from a series of bands or swaths generated in several directions through the deposit. Using the swath plot, grade variations from the OK model are compared to the distribution derived from the NN grade model and source composites. On a local scale, the NN model does not provide reliable estimations of grade but, on a much larger scale, it represents an unbiased estimation of the grade distribution based on the underlying data. Therefore, if the OK model is unbiased, the grade trends may show local fluctuations on a swath plot, but the overall trend of the OK should be similar to the NN distribution of grade.

Swath plots were generated for copper, molybdenum and gold along east-west and north-south directions and for elevation. Swath widths were 75, 75, and 20m wide for east west, north south and elevation, respectively. Items plotted include Cu, Mo, and Au grades by OK and NN for all estimated blocks as well as the corresponding capped metal grades in composites. The swath plots for copper are shown in Figure 14-13 to Figure 14-15. According to the swath plots, there is good correlation between the modelling methods. The degree of smoothing in the NN model is evident in the peaks and valleys shown in some swath plots; however, this comparison shows close agreement between the OK and NN models in terms of overall grade distribution as a function of easting, northing, and elevation, especially where there are high tonnages (vertical bars on the plots). The plots also demonstrate the high degree of variance of the input composites and the model smoothing of the composite grades.



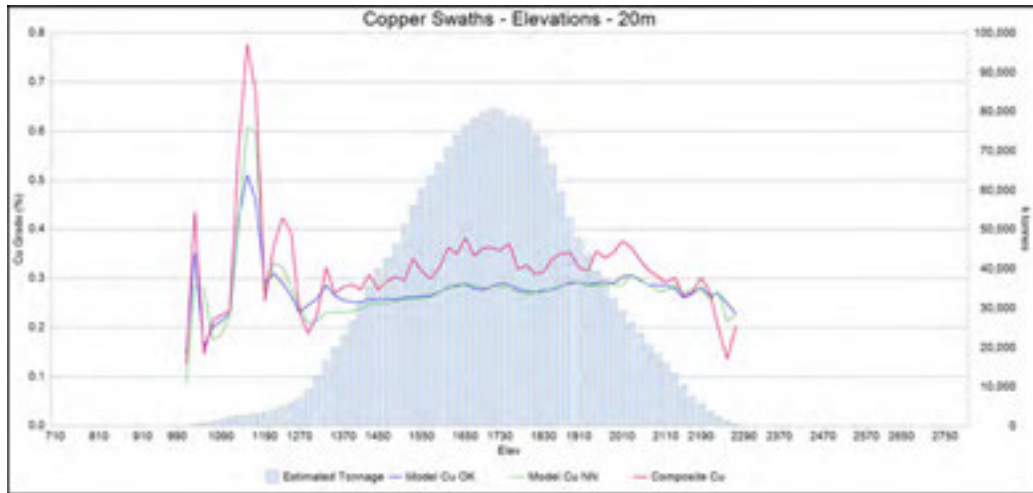
Source: 2016

**Figure 14-13: East/West Copper Swath Plot – 75m**



Source: SRK, 2016

**Figure 14-14 : North/South Copper Swath Plot – 75m**



Source: SRK, 2016

**Figure 14-15: Elevation Copper Swath Plot – 20m – All Domains**

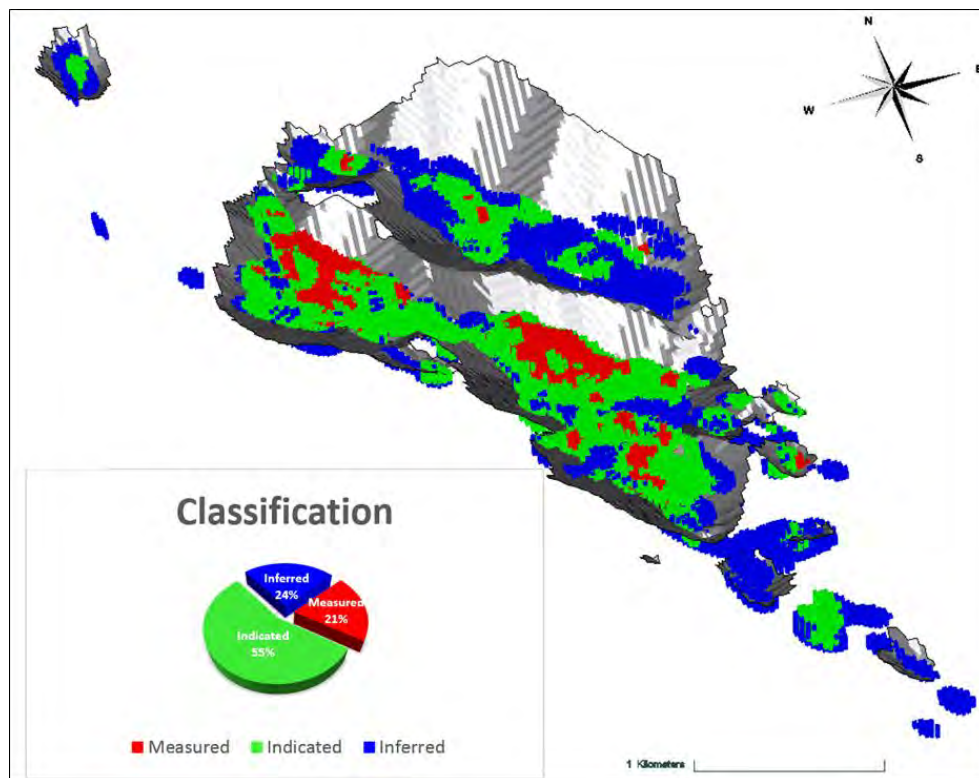
## 14.15 Resource Classification

Resources were classified into Measured; Indicated and Inferred categories based on CIM Definition Standards compliant with NI 43-101 reporting. A minimum of three drillholes were required for the assignment of Measured Mineral Resources within a drill data spacing of 50m. Indicated resources were classified with a minimum of two drillholes but within a drill data spacing of 100m. Inferred resources represent material estimated by as few as one drillhole at a distance greater than 100m from source data, but within the copper grade shell and within the potential mining shape.



Classification using a purely statistical approach occasionally produces artefacts, blocks that fail mathematical criteria but are clearly related to adjacent blocks. Therefore, to finalize classification, SRK generated wireframes for Measured and Indicated categories. The wireframes were based on a block's interpolation pass, number of drillholes, and average distance to data; as well as an interpretation of geologic continuity. By building classification wireframes based on a combination of statistics and geology, blocks of contiguous confidence are appropriately categorized and facilitate future mine planning.

An oblique view of model blocks showing the distribution of Measured, Indicated and Inferred categories is provided in Figure 14-16. The high percentage of Measured and Indicated resources compared to Inferred in this model represents a previous drilling bias toward defining reserves rather than developing and expanding resources. Gremi, Omora, and Imbruminda are densely drilled, resulting in high resource classification in those areas. Additional inter-deposit drilling and step-out exploration carried out in 2016 produced a higher percentage of Inferred resource in 2016 compared to 2015.



Source: SRK. 2016

**Figure 14-16: Yandera Estimated Blocks Coloured by Classification Code**

## 14.16 Mineral Resource Statement

The Mineral Resource statement for the Yandera deposit is presented in Table 14-16, which includes a separate statement for oxide and sulphide material. To comply with NI 43-101 and satisfy the guideline that reported mineralization have "reasonable prospect for eventual economic extraction," SRK reports Mineral Resources within a Lerchs-Grossmann (LG) optimized pit shape. The optimized pit defining the mineral resource is shown Figure 14-17.



**Table 14-16: Mineral Resource Statement for the Yandera Copper, Molybdenum, Gold Deposit, Madang Province, Papua New Guinea [0.15 CuEq (%) Cut-off] SRK Consulting, December 15, 2016**

Zone	Classification	Mass	Metal Grades				Contained Metal				
		(kt)	CuEq (%)	Cu (%)	Mo (%)	Au (ppm)	CuEq (kt)	Cu (kt)	Mo (kg)	Au (kg)	Au (koz)
Total Resource	Measured	196,480	0.46	0.38	0.01	0.10	895	742	26	18,878	607
	Indicated	530,406	0.36	0.31	0.01	0.06	1,911	1,652	46	30,636	985
	<b>Measured &amp; Indicated</b>	<b>726,886</b>	<b>0.39</b>	<b>0.33</b>	<b>0.01</b>	<b>0.07</b>	<b>2,805</b>	<b>2,393</b>	<b>73</b>	<b>49,514</b>	<b>1,592</b>
	Inferred	227,108	0.32	0.29	0.00	0.04	728	663	11	8,080	260
Oxide Resource	Measured	19,529	0.42	0.37	0.01	0.12	82	72	1	2,321	75
	Indicated	44,203	0.36	0.33	0.01	0.07	159	146	2	2,902	93
	<b>Measured &amp; Indicated</b>	<b>63,733</b>	<b>0.38</b>	<b>0.34</b>	<b>0.01</b>	<b>0.08</b>	<b>242</b>	<b>219</b>	<b>4</b>	<b>5,223</b>	<b>168</b>
	Inferred	18,443	0.27	0.26	0.00	0.03	51	48	1	599	19
Non Oxide Resource	Measured	176,951	0.46	0.38	0.01	0.09	812	669	25	16,557	532
	Indicated	486,203	0.36	0.31	0.01	0.06	1,752	1,505	44	27,735	892
	<b>Measured &amp; Indicated</b>	<b>663,153</b>	<b>0.39</b>	<b>0.33</b>	<b>0.01</b>	<b>0.07</b>	<b>2,564</b>	<b>2,175</b>	<b>69</b>	<b>44,291</b>	<b>1,424</b>
	Inferred	208,665	0.32	0.29	0.01	0.04	677	615	11	7,481	241

- Mineral Resources are not Mineral Reserves and do not have demonstrated economic viability. There is no certainty that any part of the Mineral Resources estimated will be converted into a Mineral Reserves estimate;
- Resources stated as contained within a potentially economically minable open pit; pit optimization was based on assumed copper, molybdenum, and gold prices of USD3.35/lb, USD10.00/lb, and USD1,400.00/oz, respectively; hypogene and transition recoveries of 90% for Cu, 85% for Mo, 65% for Au; oxide recoveries of 60% for Cu, 0% for Mo, 43.3% for Au; a mining cost of USD2.50/t, an ore processing and G&A cost of USD7.50/t, and a pit slope of 45 degrees;
- Resources are reported using a 0.15 % CoG on an Equivalent Copper value that included process recoveries for metal;
- The CuEq was calculated using the formula  $CuEq = Cu\% + (Mo\% * 2.82) + (Au\ ppm * 0.44)$ ; and,
- Numbers in the table have been rounded to reflect the accuracy of the estimate and may not sum due to rounding

### 14.16.1 Calculation of Cut-off Grade

A breakeven CoG of 0.15% CuEq was applied to report resources. The CoG for the resource was determined using a copper sales price of USD3.35/lb, copper recovery of 90%, ore and waste mining costs of USD2.50/t, processing and G&A costs of USD7.50/t and a 2% royalty. The calculation for determining the CoG was:

$$\text{Breakeven CoG} = \frac{\text{Mining Cost Ore} + \text{Processing and G\&A Costs}}{\text{Cu Price} \times (\text{Process Recovery} - \text{Royalty}) \times 22.046}$$

### 14.16.2 Pit Limited Resource

Pit optimization was performed on the Yandera model using MineSight Economic Planner (MSEP). MSEP employs the industry-accepted Lerchs-Grossmann algorithm, which determines the maximum pit extents by optimizing the stripping ratio.

Blocks classified as Measured, Indicated and Inferred were all used to define the resource pit shell. Input criteria for the pit optimization, including prices and recoveries for all metals, are described in the footnotes of the Resource Statement. It was assumed during pit optimization that molybdenum and gold would not be recovered from oxide material.

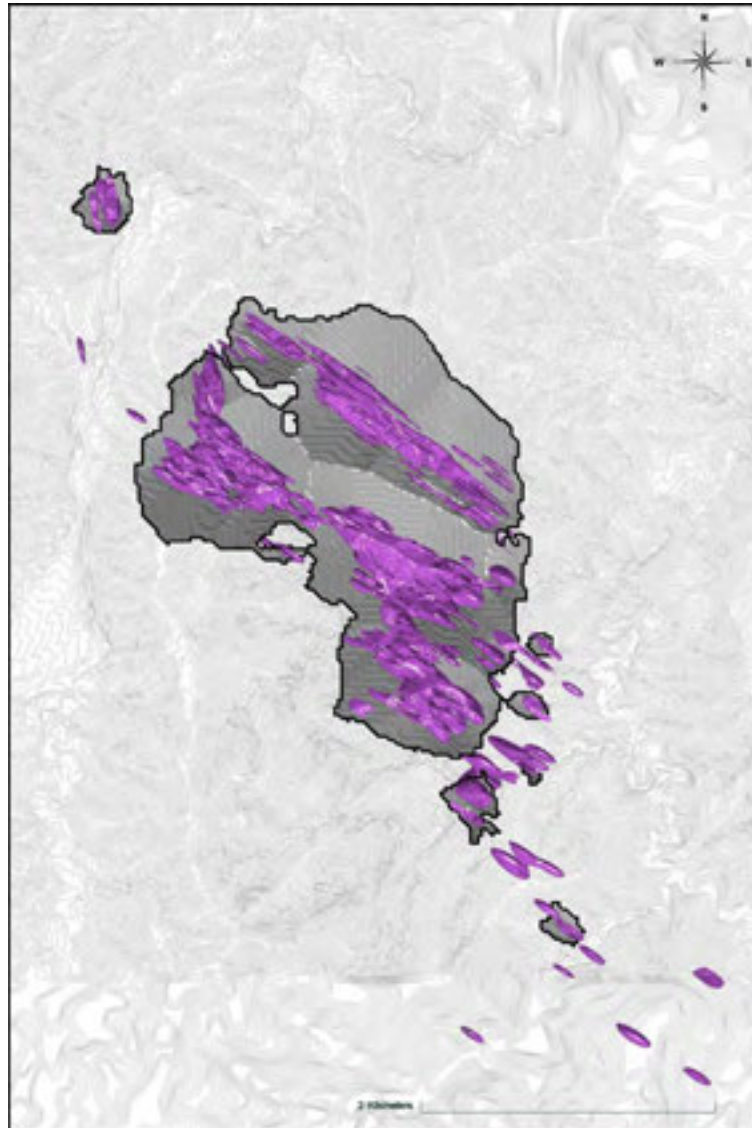


### 14.16.3 Calculation of Copper Equivalent

The following metal ratios were used for reporting CuEq in the resource statement:

$$\text{CuEq} = \text{Cu}\% + (\text{Mo}\% * 2.82) + (\text{Au ppm} * 0.44)$$

These metal ratios were developed using the metal prices and recovery assumptions listed in the CoG calculation above. Recoveries are based on metallurgical test work carried out by Marengo in 2011.



Source: SRK, 2016

**Figure 14-17: Yandera 2016 Resource Pit in Plan with 1,500ppm Copper Interpolation Domains**





## 14.17 Mineral Resource Sensitivity

As per industry standards, the Yandera mineral resource is reported below at variable cut-offs within the 2016 resource pit at incremental CoGs to demonstrate the sensitivity of the resource. These sensitivities are provided for the total resource, oxide resource and non-oxide resource in Table 14-17.

**Table 14-17: Yandera Total MI&I Resource Sensitivity within the 2016 SRK Resource Pit**

Resource	CuEq CoG (%)	Metal Grades					Contained Metal
		Mass (kt)	CuEq (%)	Cu OK (%)	Mo OK (%)	Au OK (%)	CuEq (kt)
Total	0.100	973,288	0.37	0.32	0.009	0.060	3,565
	0.125	969,539	0.37	0.32	0.009	0.060	3,561
	0.150	959,285	0.37	0.32	0.009	0.060	3,546
	0.175	932,451	0.38	0.32	0.009	0.062	3,502
	0.200	879,899	0.39	0.33	0.009	0.064	3,403
	0.225	807,308	0.40	0.35	0.010	0.068	3,249
	0.250	718,465	0.42	0.36	0.011	0.073	3,038
	0.275	627,834	0.45	0.38	0.011	0.078	2,800
	0.300	545,234	0.47	0.40	0.012	0.084	2,563
Oxide	0.100	83,320	0.35	0.32	0.005	0.070	294
	0.125	83,172	0.35	0.32	0.005	0.070	294
	0.150	82,343	0.36	0.32	0.005	0.071	292
	0.175	78,900	0.36	0.33	0.005	0.073	287
	0.200	73,431	0.38	0.34	0.006	0.077	276
	0.225	65,688	0.40	0.36	0.006	0.083	260
	0.250	57,792	0.42	0.38	0.006	0.089	241
	0.275	49,057	0.45	0.40	0.007	0.098	218
	0.300	43,086	0.47	0.42	0.007	0.105	201
Non Oxide	0.100	889,969	0.37	0.32	0.009	0.059	3,272
	0.125	886,368	0.37	0.32	0.009	0.059	3,267
	0.150	876,943	0.37	0.32	0.009	0.059	3,254
	0.175	853,551	0.38	0.32	0.009	0.061	3,216
	0.200	806,469	0.39	0.33	0.010	0.063	3,127
	0.225	741,620	0.40	0.35	0.010	0.067	2,989
	0.250	660,673	0.42	0.36	0.011	0.071	2,797
	0.275	578,776	0.45	0.38	0.012	0.077	2,582
	0.300	502,148	0.47	0.40	0.013	0.082	2,362

Source: SRK, 2016

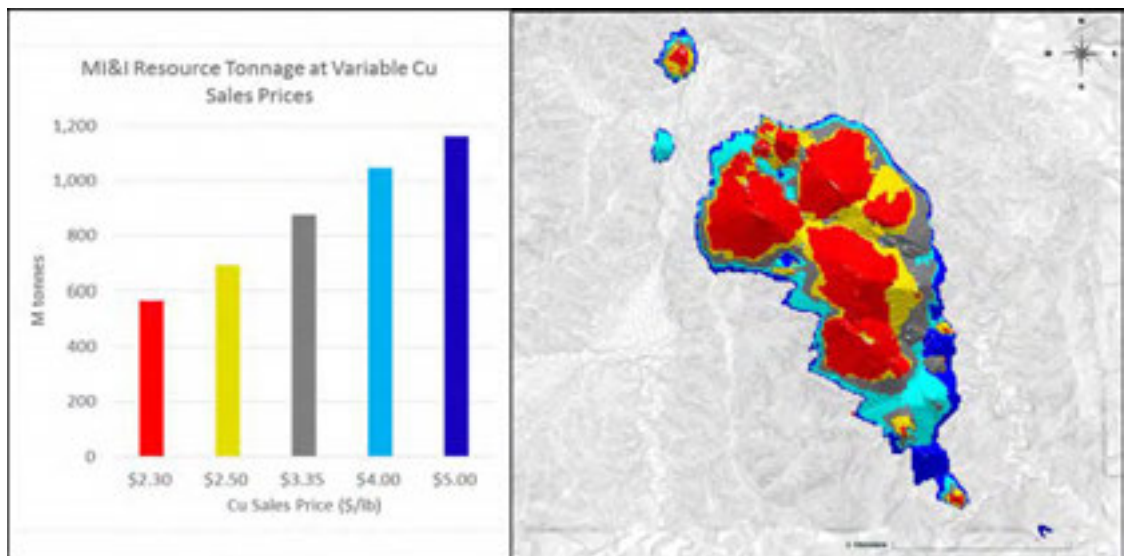


## 14.18 Relevant Factors

For this study, SRK did not identify any environmental, permitting, legal, title, taxation, marketing or other non-technical factors that could affect resources.

## 14.19 Resource Potential

In addition to the in-pit resource sensitivity, SRK generated a series of pits at varying metal sales prices. Figure 14-18 shows the resulting pits from this work along with the resource tonnages within those pits reported at a CuEq cut-off of 0.15 %. The bar graph in Figure 14-18 indicates the number of potential resource tonnes over a range of metal prices. The analysis highlights target areas for further exploration. For example, areas between pits that may contain metal but have not been adequately tested represent immediate drill targets to increase the resource. Similarly, any other prospects that are contiguous to this pit shape and could potentially share stripping with known mineralization become high priority targets.



Source: SRK, 2016

**Figure 14-18: Optimized Pit Price Sensitivity Reported at a CuEq Cut-off of 0.15%**

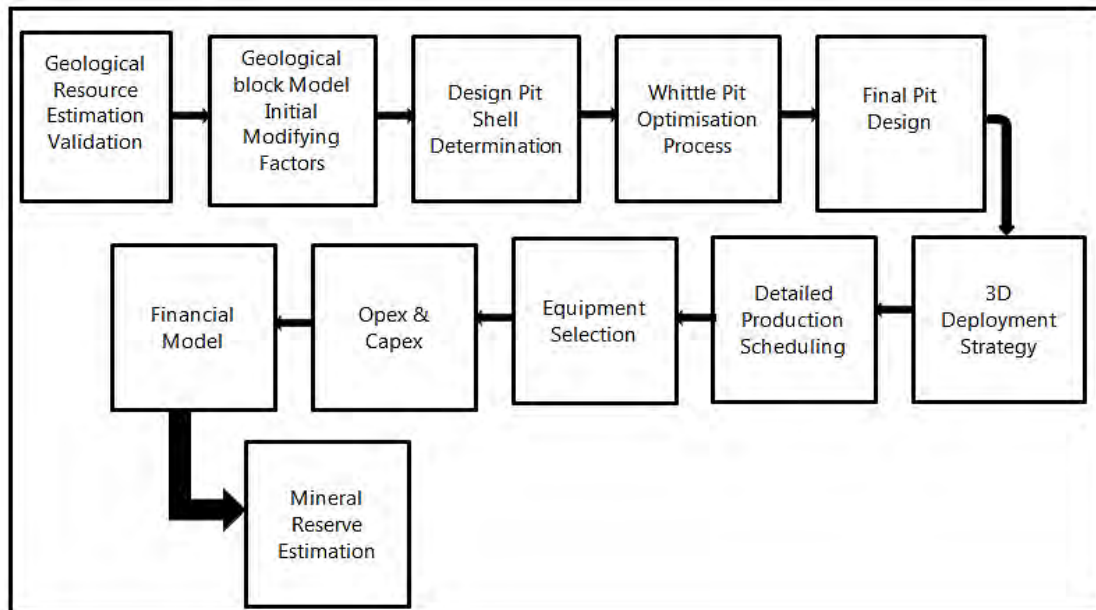




## 15 Mineral Reserves Estimates

### 15.1 Introduction

This section describes the steps followed in estimating potentially economically mineable reserves and determining the likely magnitude of such a reserve estimate. Figure 15-1 depicts the process followed to arrive at the mineral reserves estimation.



**Figure 15-1: Process for Mineral Reserves Estimation**

The process depicted in the top line of Figure 15-1 preceding the final pit design forms the basis of the final size of the Reserve Estimate and the modifying factors used in the conversion from Resource to Reserve are described in detail in sections 15.2 to 15.9 to elaborate on the following aspects of the study:

- Geological Resource Estimate Validation.
- Analysis of Mining Losses already included in the geological block model.
- Analysis of Dilution already included in the geological block model.
- Determination of Selective Mining Dilution for inclusion as a modifying factor.
- Removal of Inferred Resources from the Reserve analysis.
- Macro-Economic Assumptions.
- Preliminary Opex for Whittle Inputs (Processing and Mining).
- Basis for Recovery Prediction for Preliminary Whittle Analysis.
- Concentrate Grade Prediction.
- Geotechnical considerations.
- Whittle Analysis Progression Chart.
- Pit Size and Ore Tonnage Sensitivity Analysis.



- Whittle Pit Shell Selection.
- Initial Pit Design.

## 15.2 Geological Resource Estimate Validation

As per the requirements of the Canadian Institute of Mining Best Practice Guidelines for the Estimation of Mineral Resources and Mineral Reserves for NI 43-101 compliant Reserve Estimates, it is the responsibility of the QP to ensure the verification of all inputs into the Mineral Reserve estimate. As the Mineral Reserve estimate is based on many data inputs, including the Mineral Resource model, it is important that the inputs and the consistency of inputs be validated as part of the Mineral Reserve estimation process.

In order to validate the Resource Estimate, the geological block model (Yandera\_2016\_Resource\_Block\_Model\_JLS\_20170206.csv), was imported into the GEOVIA Whittle 4.6 Software.

The Whittle software package is currently considered the premier open pit optimizer and is used as a benchmark for mining studies throughout the world. Essentially, it answers the question of how big an open pit should be to maximize the net profit value of the Project. Whittle software makes use of the Lerchs-Grossmann algorithm and is used to determine and optimize the economics of open pit mining projects. The software's capabilities enable analysis of pit designs in the context of physical, economic and mining constraints, allowing significant value to be added to operations. The input parameters used to validate the Resource Estimate pit shell are summarized in Table 15-1 and the resource estimate, which resulted from Whittle, is displayed in Table 15-2. The results coincide with previously estimated results as indicated in Table 14-16.

**Table 15-1: Input Parameters for the Resource Estimation Validation**

Parameter	Value	Unit	
Mining Cost	2.50	USD/t	
Processing Cost per milled tonne	7.50	USD/t	
Royalty (based on revenue)	2	%	
Slope	45	°	
CuEq cut-off	0.15	%	
<b>Prices</b>			
Cu	3.35	USD/lb	
Mo	10	USD/lb	
Au	1,400	USD/oz	
<b>Recoveries</b>			
Item	Oxides	Non Oxides	Unit
Cu	60	90	%
Mo	0	85	%
Au	43.3	65	%



**Table 15-2: Resource Estimation Validation**

Zone	Classification	Mass	Metal Grades				Contained Metal				
		(kt)	CuEq (%)	Cu (%)	Mo (%)	Au (ppm)	CuEq (kt)	Cu (kt)	Mo (kg)	Au (kg)	Au (koz)
Total Resource	Measured	196,480	0.46	0.38	0.01	0.10	895	742	26	18,878	607
	Indicated	530,406	0.36	0.31	0.01	0.06	1,911	1,652	46	30,636	985
	<b>Measured &amp; Indicated</b>	<b>726,886</b>	<b>0.39</b>	<b>0.33</b>	<b>0.01</b>	<b>0.07</b>	<b>2,805</b>	<b>2,393</b>	<b>73</b>	<b>49,514</b>	<b>1,592</b>
	Inferred	227,108	0.32	0.29	0.00	0.04	728	663	11	8,080	260
Oxide Resource	Measured	19,529	0.42	0.37	0.01	0.12	82	72	1	2,321	75
	Indicated	44,203	0.36	0.33	0.01	0.07	159	146	2	2,902	93
	<b>Measured &amp; Indicated</b>	<b>63,733</b>	<b>0.38</b>	<b>0.34</b>	<b>0.01</b>	<b>0.08</b>	<b>242</b>	<b>219</b>	<b>4</b>	<b>5,223</b>	<b>168</b>
	Inferred	18,443	0.27	0.26	0.00	0.03	51	48	1	599	19
Non Oxide Resource	Measured	176,951	0.46	0.38	0.01	0.09	812	669	25	16,557	532
	Indicated	486,203	0.36	0.31	0.01	0.06	1,752	1,505	44	27,735	892
	<b>Measured &amp; Indicated</b>	<b>663,153</b>	<b>0.39</b>	<b>0.33</b>	<b>0.01</b>	<b>0.07</b>	<b>2,564</b>	<b>2,175</b>	<b>69</b>	<b>44,291</b>	<b>1,424</b>
	Inferred	208,665	0.32	0.29	0.01	0.04	677	615	11	7,481	241

## 15.3 Initial Mining Modifying Factors

### 15.3.1 Mining Losses

For the purpose of this study, mining losses were regarded as the portion of the ore body included in the geological grade shell wireframes, but not classified as ore in the block model and will therefore not report as Reserves. Mining losses are relevant to ore tonnages.

The occurrence of mining losses in open pit mining is due to the size of mining equipment used and grade control methods applied. The combination of equipment size and the grade control practice determines the extent to which selective mining can be performed in order to retrieve as much ore as possible at the ore/waste boundary.

When assessing the quantum of the mining loss factor to be applied as a modifying factor in the Resource to Reserve conversion process, it is important to determine the extent to which such losses may already be included in the methods used to construct the block model from the original ore body wireframes.

The methodology used in compiling the block model, particularly the way in which ore losses are accounted for in the 25 by 25 by 10m ore blocks, is important.

Due to the block sizes of 25 by 25 by 10m and their interaction with the delineation of the ore shells, some ore blocks were 'discarded' as ore and classified as waste. The blocks containing ore, but classified as waste, are generally those where the centroid of the block fell outside of the ore shell perimeter. These portions are represented by the empty (no blocks) spaces inside the ore shell delineation as depicted in Figure 15-2.

The blocks in the Resource model were flagged as mineralized if at least 50% of the block volume was within the grade shell solid. If less than 50% of the block was within the shell, it was not included in the mineralized domain and no grades were estimated to that block (i.e., all blocks with less than 50% of their volume within the grade shell were considered waste.) For resource reporting, if a mineralized block had an estimated CuEq grade above the cut-off, the entire block volume was reported as ore.

A breakeven CoG of 0.15% CuEq was applied to report resources. The CoG for the resource was determined using a copper sales price of USD3.35/lb, copper recovery of 90%, ore and waste mining costs of USD2.50/t, processing and G&A costs of USD7.50/t, and a 2% royalty. The calculation for determining the CoG was:

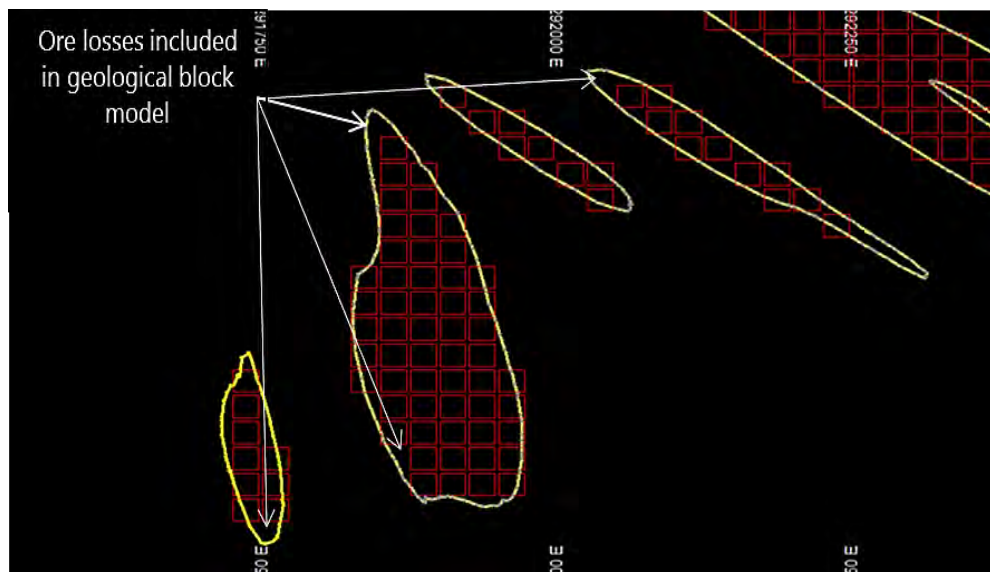
Breakeven CoG = Mining Cost Ore + Processing and G&A Costs:

$$\text{Cu Price} \times (\text{Process Recovery} - \text{Royalty}) \times 22.046$$

The resources were reported within the pit configuration above a breakeven CuEq CoG of 0.15%. The metal ratios used for reporting CuEq were:

$$\text{CuEq} = \text{Cu}\% + (\text{Mo}\% \times 2.82) + (\text{Au ppm} \times 0.44)$$

A sample was taken within the orebody to calculate the impact of the in- and out of the ore shell impact. Ten benches were chosen as samples, 120m apart in elevation extending from 2145mamsl down to 1065mamsl. The entire level was considered and not only individual outlines. The size of sample was deemed representative. The samples were also widespread in the elevation axis and thus not clustered.



**Figure 15-2: Ore Losses Depicted as Voids between Blocks and Grade Shell Perimeter**

The results are depicted in Figure 15-3 and would, in principle, equate to a 2.2% mining loss applied to the ore shell. This translated to an already built in ore loss of 2.2% when the ore shells were converted to the geological block model.

All the ore blocks in the geological model were, therefore, considered in the Reserve Estimate, as the ore blocks already represent a 2.2% loss when compared to ore shells.

This ore loss is deemed sufficient in terms of the mining fleet and grade control practices to be used. No further mining dilution was applied as a resource to reserve modifying factor. Due to the inclusion of sufficient ore losses in the construction of the geological block model, a mining loss of 0% was used during the conversion process from the Resource Estimate to the Reserve Estimate.



**Table 15-3: Ore Losses Already Included in Block Model**

Elevation	Block Model Area	Ore Shell Area	Ore Loss %	Ore Loss
2145	145,625	151,539	3.90%	5,914
2025	385,000	390,742	1.47%	5,742
1905	653,125	678,107	3.68%	24,982
1785	1,076,250	1,094,250	1.65%	18,000
1665	1,051,250	1,078,493	2.53%	27,243
1545	751,250	763,063	1.55%	11,813
1425	455,625	464,926	2.00%	9,301
1305	130,625	131,405	0.59%	780
1185	43,750	43,327	-0.98%	(423)
1065	8,125	9,887	17.82%	1,762
<b>Total</b>	<b>4,700,625</b>	<b>4,805,740</b>	<b>2.19%</b>	<b>105,115</b>

### 15.3.2 Mining Dilution

For the purposes of this study, mining dilution was regarded as the extent to which the in-situ block model metal grades need to be reduced to reflect the impact of mining and thus the inclusion of waste with the ore delivered to the processing plant. Mining dilution is relevant to ore grades.

Similar to mining losses, the occurrence of mining dilution in open pit mining is due to the size of mining equipment used and grade control methods applied. The combination of equipment size and the grade control practice determines the extent to which selective mining can be performed in order to retrieve as much ore as possible and include as little waste as possible at the ore/waste boundary.

When assessing the quantum of the mining dilution factor to be applied as a modifying factor in the Resource to Reserve conversion process, it is important to determine the extent to which waste inclusion or ore dilution may already be included in the methods used to construct the block model from the original ore body wireframes.

The methodology used to construct the geological block model, particularly addressing the way in which dilution was already included in the 25 by 25 by 10m ore block representing the Resource Estimate, was, therefore, an important consideration.

The block model was built to support the NI 43-101 technical report on Resource Estimation. For this purpose, it was built on a full block basis with some internal and external dilution factored in by including lower grade intervals within the grade shell to accommodate some basic assumptions on the scale of mining.

The final constraint on grade estimation was a grade-limiting boundary (grade shell) that was constructed tracking lithologic contacts and honouring the identified structural trends. For the primary metal, copper wireframes were constructed around composites using a CoG of 0.15% Cu.



This CoG was determined based on early estimates of the project economics. Low-grade intervals that are internal to the overall grade shell were included in the domain to account for internal dilution that would be expected during mining. All resources were reported inside the copper grade shell.

Several aspects of resource modelling have already accounted for some of the dilution. From the resource modelling perspective, compositing, grade domaining, interpolation methodology and model block size have contributed to address dilution to a degree.

### **15.3.2.1 Compositing**

The first level of dilution in modelling was incurred through assay compositing prior to grade estimation. Model block grades were estimated by 5-m composites from original 2- and 3-m raw assay values.

### **15.3.2.2 Grade Domaining**

The second level of dilution in modelling was in the development of grade wireframes. The extent of mineralization was defined using a wireframe boundary, which was subsequently coded into the block model. The purpose of the wireframe was to constrain grade estimation within a distance from data deemed appropriate relative to the source data and style of the deposit. For this exercise, a long drillhole composite length of 50m was applied initially to define the wireframe's outer boundary and limit the exclusion of internal low-grade. Using this technique, the outer boundary of the modelled mineralization has been smoothed and internal low grade has been included, allowing for low-grade composites to impact (dilute) the estimates of neighbouring high-grade composites.

### **15.3.2.3 Interpolation Methodology**

The third level of dilution has been imparted by the interpolation method. Grades in the Yandera resource model were estimated by OK, a statistically robust, industry standard method for estimating bulk tonnage, low-grade deposits that are expected to be mined in large throughput operations. OK produces an interpolation result that increases tonnage and decreases grade compared to other methods.

### **15.3.2.4 Model Block Size**

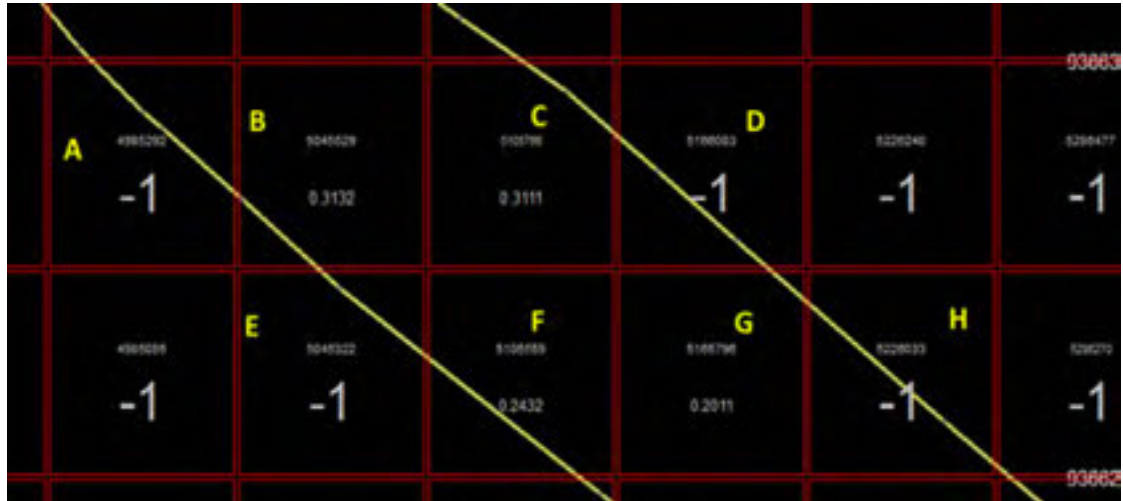
The fourth level of dilution in modelling was imparted by the size of the model blocks. The model block size of 25 by 25 by 10m (X, Y, Z) was a compromise between the drill data spacing and the Selective Mining Unit (SMU) anticipated for the Project. The dimensions of the blocks chosen had the effect of diluting the 5-m composites.

### **15.3.2.5 Theoretical Mining Dilution**

Despite the dilution already applied to the block model, block grade values consist of the interpolated grade assigned to the block during estimation. Blocks are therefore considered ore or waste on a full block basis in the resource. When assessing the grades in blocks that cut through the grade shell perimeter, such as Block C in Figure 15-3, the grade estimated into the block is based on surrounding values (within the search ellipse and using OK) only from inside the grade shell wireframes.



As the block extends beyond the grade shell perimeter into waste, the resultant grade should be based on the weighted average (per area or per volume) of the higher-grade portion of the block inside of the grade shell perimeter, and the zero grade area outside of the grade shell perimeter. If this dilution calculation is not made, the grade of the bigger portion of the block inside the grade shell perimeter is allocated to smaller block portion outside of the grade shell perimeter, thus increasing the volume of ore at the same grade.



**Figure 15-3: Mining Dilution depicted by Ore Blocks extending into Waste**

At PFS level, using the resource block model, i.e., with no grade control model available, it was assumed that grade control would occur based on the bench outlines of the grade shell. For blocks with a portion outside of the grade shell outline, dilution at 0% grade has to be proportioned into such a block.

Using the same representative sample used to calculate the ore losses already included in the block model described above, the dilution percentage was calculated on a bench-by-bench basis.

This is an important step as the block model is used in the subsequent processes of pit optimization and production scheduling. It is, therefore, important to reflect the diluted grades.

For reporting dilution using the Yandera\_2016\_Resource\_BlockModel\_JLS\_20170206.csv at a PFS level, it was decided to develop bench by bench estimates of dilution based on ore and waste boundaries for the sampled benches only and to apply the average of that dilution to each bench in pit optimization and scheduling.

The results of the dilution analysis are tabulated in Table 15-4.

The accuracy of the logic applied to arrive at the results tabulated for ore losses in Table 15-3 and for mining dilution in Table 15-4 was verified with the equations below and by substituting values from Table 15-3 and Table 15-4 into the equations to test for balance.

$$\text{Mining Loss} = \text{Ore Shell Area} - \text{Block Model Area}$$





Therefore:

- Block Model Area = Ore Shell Area - Mining Loss
- Void inside Ore Shell = Ore Shell Area - Block Model inside Ore Shell

Therefore:

- Block Model inside Ore Shell = Ore Shell Area - Void inside Ore Shell
- Block Model outside Ore Shell = Block Model Area - Block Model inside Ore Shell  
= Ore Shell Area - Mining Loss - Ore Shell Area +  
Void inside Ore Shell  
= Void inside Ore Shell - Mining Loss
- Check with Numbers = 646,418 - 105,115  
= 541,303  
= Block Model outside Ore Shell  
= 541,303

It was concluded that the logic applied to determine mining losses and dilution was sound.

The magnitude of the calculated mining loss at 11.5% to be applied to each ore block, based on the horizontal block dimensions of 25 by 25m, was deemed to be excessive as more accurate mining would likely be possible during the operational phase of the mine, and the SMU would be smaller than the geological block sizes used in the block model.

A more representative practical mining dilution was, therefore, determined to be applied as a modifying factor for the Yandera PFS Resource to Reserve conversion.



**Table 15-4: Mining Dilution to be added to the Block Model**

Elevation	BM inside Ore Shell	Void inside Ore Shell	BM outside Ore Shell	SG	Ave Cu%	Cu in BM inside Ore Shell	Cu in BM	Content Dilution	Content Variance	Area Dilution	Area Variance
2145	128,594	22,945	17,031	2.48	0.288	9,188	10,405	11.70%	1,217	11.70%	17,031
2025	346,036	44,706	38,964	2.55	0.343	30,329	33,744	10.12%	3,415	10.12%	38,964
1905	578,553	99,554	74,572	2.62	0.316	47,811	53,974	11.42%	6,163	11.42%	74,572
1785	953,238	141,012	123,012	2.61	0.299	74,353	83,948	11.43%	9,595	11.43%	123,012
1665	937,024	141,470	114,226	2.63	0.302	74,576	83,667	10.87%	9,091	10.87%	114,226
1545	640,266	122,797	110,984	2.62	0.286	48,047	56,375	14.77%	8,328	14.77%	110,984
1425	406,972	57,954	48,653	2.63	0.270	28,944	32,404	10.68%	3,460	10.68%	48,653
1305	120,545	10,860	10,080	2.62	0.252	7,954	8,619	7.72%	665	7.72%	10,080
1185	40,377	2,949	3,373	2.62	0.270	2,850	3,088	7.71%	238	7.71%	3,373
1065	7,717	2,170	408	2.63	0.198	402	423	5.03%	21	5.03%	408
<b>Total</b>	<b>4,159,322</b>	<b>646,418</b>	<b>541,303</b>			<b>324,454</b>	<b>366,647</b>	<b>11.51%</b>	<b>42,194</b>	<b>11.52%</b>	<b>541,303</b>

At more detailed levels of mine planning (i.e., feasibility) it is suggested that a new model be developed that takes into account more refined block size, ore percentage per block and adjusted grade shell methodology to relate more appropriately to the selected mining method and equipment sizing expected to be used during operations.



### 15.3.3 Selective Mining Dilution as a Modifying Factor

From Table 15-4 above, the calculated dilution, based on the blocks extending across the grade shell perimeter on each bench compared to the block volumes inside the grade shell perimeter is 11.5%. The blocks classified, as ore are those, which had their centroid position inside the grade shell perimeter, i.e., more than 50% of the block was within the grade shell.

This means that for the blocks extending beyond the grade shell, the portion of the block that falls outside of the grade shell can range from just above 0% to just below 50%. As the block sizes are 25 by 25 by 10m, the biggest area by which an ore block can potentially be overstated (extending beyond the grade shell) on the grade shell perimeter is 12.5 by 25m or 312.5m<sup>2</sup>. For the purposes of this calculation, the area of 312.5m<sup>2</sup> is represented by a square of 17.7 by 17.7m.

The smallest portion extending across the grade shell perimeter can be as little as just above 0m<sup>2</sup>, and it can be assumed that on average the 11.5% dilution is based on areas of blocks representing the average of the extremes. It is therefore assumed that the 11.5% dilution is representative of an area midway between 0 and 312.5m<sup>2</sup>, represented by an area of 12.5 by 12.5m of perimeter blocks on average, extending into waste rock, or 156.25m<sup>2</sup>.

It is envisaged that grade control will be done on blast holes that are assumed to be spaced in a blast hole drill pattern of approximately 5 by 5m, covering blocks of 25m<sup>2</sup>. The effective size of waste blocks being incorrectly loaded as ore and contributing to dilution therefore reduces from 156.25m<sup>2</sup> to 25m<sup>2</sup>.

If the 11.5% dilution is proportionally decreased, the resultant theoretical dilution is only 1.84%.

This theoretical grade control dilution was further adjusted with factors for ore shape anomalies, blast movement and operator error to result in the final calculated dilution of 3%.

A factor of 15% was added for localized ore shape anomalies for cases where a blast hole (or most of it) can be located in ore but most of the 25m<sup>2</sup> can still be in waste, raising the theoretical dilution to 2.12%.

A 30% factor for blast movement was added to the dilution, increasing the estimated dilution to 2.75%. (Mining losses are not further penalized by the blast movement phenomenon, as the original 2.2% block model ore losses were deemed sufficient to include ore losses attributable to blast movement.)

A 10% factor for operator error increased the final calculated dilution to 3%. Again, mining losses were not further increased because of operator error as it is deemed that the original 2.2% block model ore losses are sufficient and include ore losses attributable to operator error.

If grade control sampling, assaying and demarcation are applied, the practical mining dilution was estimated to be 3%.

Both the theoretical and practical mining dilution percentages were applied in the pit optimization process to show the sensitivity of this modifying factor on pit size and ore tonnage.

The 3% mining dilution was carried forward in the Resource to Reserve conversion process.



## 15.4 Design Pit Shell Determination

### 15.4.1 Removal of Inferred Resources from Reserve Analysis

For reporting in line with NI 43-101, Inferred Mineral Resources are considered too speculative to apply the economic considerations that could influence the estimation of mineral reserves. The Instrument prohibits the disclosure of the results of an economic analysis that includes or is based on Inferred Mineral Resources.

The first step in the conversion from Resources (as depicted Table 15-5) to Reserves was to exclude the ability of Inferred Resources in the block model to contribute to the economic viability when analysing potential pit sizes. This was achieved by reducing the metal content of Inferred Resources to zero in order to prevent it from contributing to revenue, but to still represent the correct density to be taken into account as waste tonnage during the economic evaluation of the mining process.

**Table 15-5: Resource Estimation Validation**

Zone	Classification	Mass	Metal Grades				Contained Metal				
		(kt)	CuEq (%)	Cu (%)	Mo (%)	Au (ppm)	CuEq (kt)	Cu (kt)	Mo (kg)	Au (kg)	Au (koz)
Total Resource	Measured	196,480	0.46	0.38	0.01	0.10	895	742	26	18,878	607
	Indicated	530,406	0.36	0.31	0.01	0.06	1,911	1,652	46	30,636	985
	<b>Measured &amp; Indicated</b>	<b>726,886</b>	<b>0.39</b>	<b>0.33</b>	<b>0.01</b>	<b>0.07</b>	<b>2,805</b>	<b>2,393</b>	<b>73</b>	<b>49,514</b>	<b>1,592</b>
	Inferred	227,108	0.32	0.29	0.00	0.04	728	663	11	8,080	260
Oxide Resource	Measured	19,529	0.42	0.37	0.01	0.12	82	72	1	2,321	75
	Indicated	44,203	0.36	0.33	0.01	0.07	159	146	2	2,902	93
	<b>Measured &amp; Indicated</b>	<b>63,733</b>	<b>0.38</b>	<b>0.34</b>	<b>0.01</b>	<b>0.08</b>	<b>242</b>	<b>219</b>	<b>4</b>	<b>5,223</b>	<b>168</b>
	Inferred	18,443	0.27	0.26	0.00	0.03	51	48	1	599	19
Non Oxide Resource	Measured	176,951	0.46	0.38	0.01	0.09	812	669	25	16,557	532
	Indicated	486,203	0.36	0.31	0.01	0.06	1,752	1,505	44	27,735	892
	<b>Measured &amp; Indicated</b>	<b>663,153</b>	<b>0.39</b>	<b>0.33</b>	<b>0.01</b>	<b>0.07</b>	<b>2,564</b>	<b>2,175</b>	<b>69</b>	<b>44,291</b>	<b>1,424</b>
	Inferred	208,665	0.32	0.29	0.01	0.04	677	615	11	7,481	241

The Whittle pit optimizing software was re-run on the same input parameters as for the Resource Estimation Validation, as indicated in Table 15-5.

The pit shell reduced in size in terms of total potential ore tonnes from 953,994t to 653,139t. This is a reduction of 300,855t or 32% from total resources (including Inferred) to Measured and Indicated resources where Inferred resources had no revenue generating capacity.

When evaluated against Measured and Indicated resources, the pit size reduced from 726,886 potential ore tonnes to 660,971t. The impact is a reduction of 65,915t or 9% in Measured and Indicated Resources.

### 15.4.2 Macro-Economic Assumptions

This section summarizes the macro-economic assumptions used for the Whittle pit shell determination and optimization process. These inputs were revised during the PFS and some initial numbers used in determining the Design Pit Shell are slightly different to the final numbers applied in the economic analysis. Where uncertainty existed, more optimistic values were selected which would give the geological resources a better chance of being converted to reserves and thus maximise the potential pit size.



The more optimistic input parameters were still viewed as realistic and validation of all parameters was obtained before use in the final financial model to determine the investment case in terms of NPV and Internal Rate of Return (IRR).

### 15.4.2.1 Functional Currency

Cost estimates and pricing assumptions were provided in US dollars but were adjusted to reflect in-country expenditure where relevant.

### 15.4.2.2 Escalation Factors and Consumer Price Index

The financial model and project valuation considers all cash flows in real terms. Income tax, however, is calculated in nominal terms and a US inflation rate is applied for these escalations. The income tax calculation is then de-escalated to obtain a real value. Cost elements were assessed on an individual basis in order to determine whether above- or below-inflationary increases should be applied.

Historic US Consumer Price Indices (CPI) have mostly remained below 2% in the past. The Federal Open Market Committee also implements monetary policy to help maintain an inflation rate of 2% over the medium term.

Table 15-6 indicates the long-term CPI forecasts of selected analysts. The average value in the table, which amounts to 2.0%, is in line with the US CPI target. As such, an inflation factor of 2% was applied in the financial model and Whittle inputs, where relevant.

**Table 15-6: Long-term CPI Forecasts**

Source	Long-term CPI
Economic Intelligence Unit (Knoema, 2016)	1.9%
IEconomics, 2017	1.7%
International Monetary Fund (Knoema, 2016)	2.4%
Statistica, 2017	2.3%
Trading Economics, 2017	1.9%
<b>Average</b>	<b>2.0%</b>

### 15.4.3 Copper Price

The copper price was obtained from a purchased Wood Mackenzie report. Wood Mackenzie is a reputable firm with over forty years' experience in evaluating economic and market indicators. Its forecasting methodology considers numerous aspects such as supply and demand, possible business disruptions, mine closures, new projects and other influencing factors.

Wood Mackenzie's forecast was compared to a consensus view of major banks and consultants, such as Macquarie Group Ltd, UBS, Citigroup Inc., Societe Generale SA, Standard Chartered Bank, Deutsche Bank AG, Barclays PLC, etc. Wood Mackenzie's prices differed by approximately 3% when compared to the consensus average, and were therefore accepted as reasonable.



The real copper price forecast is displayed in Table 15-7.

**Table 15-7: Wood Mackenzie Copper Price Forecast – March 2017**

Item	2017	2018	2019	2020	2021	2022	2023	2024	2025	2026
USD/t	5284	5612	6063	6504	7826	8267	8708	8267	7826	7275

#### 15.4.4 Discount Rate

The project’s discount rate is equal to Era’s Weighted Average Cost of Capital (WACC), adjusted for risks related to the Project and its location. The adjusted WACC represents the minimum expected returns, which will satisfy the company’s creditors, owners and providers of capital, as they expect certain returns for the funds that they provided.

The nominal discount rate, as calculated by Era, is 10%. The real discount rate is calculated at 7.84%, when applying the following equation:

$$\left( \frac{1 + \text{nominal discount rate}}{1 + US\ CPI} \right) - 1$$

Thus,

$$\left( \frac{1 + 10\%}{1 + 2\%} \right) - 1$$

#### 15.4.5 Gold Price

Prior to the review of the gold price assumption, a consensus gold price of USD1,267/oz (real) was applied in Whittle.

Gold is a financial asset class and currency markets, returns and dividends from equity investments and bond yields influence its trading value. A Wood Mackenzie presentation, dated 15 March 2017, indicated that gold would average between USD1,100/oz and USD1,400/oz over the next five years.

For the gold price to break out of its current range there would need to be substantial systematic risk entering the global financial system, preceded by either a major geopolitical event or a sustained slide in the economic performances of China, the USA and the EU. Wood Mackenzie’s long-term average of USD1,300/oz was, therefore, selected for purposes of this study.

Alternative price forecasts were also obtained from a consensus forecast and two JSE-listed goldmining companies. The long-term real forecasts from these sources were USD1,267/oz, USD1,220/oz and USD1,200/oz, indicating that the selected rate is not unreasonable.

For the Whittle analysis, the gold price therefore increased from USD1,267/oz to USD1,300/oz, and a sensitivity analysis was performed to indicate the impact on potential reserve and pit sizes.

Potential reserve size was very insensitive to gold price fluctuation.



## 15.4.6 Molybdenum Price

It is expected that the concentrate will contain 50% molybdenum disulphide, or molybdenite (MoS<sub>2</sub>). Consensus prices for roasted molybdenum (oxides) were obtained from research groups and banks, such as Deutsche Bank, BMI Research, Macquarie, etc. The average real price forecast is shown in Table 15-8

**Table 15-8: Molybdenum Price Forecast**

Item	2017	2018	2019	2020
USD/lb	USD7.59	USD7.89	USD8.24	USD8.89

In the light of the real price forecast in Table 15-8 Wood Mackenzie forecasted that molybdenum prices would increase above USD9/lb in 2017. Therefore, a long-term real price of USD10/lb was selected for the study, with a 15% treatment and refining charge of revenue. For the next phase of the Project, treatment and refining costs need to be confirmed. The prices above refer to molybdenum oxide concentrates. It was recommended that the Whittle optimization include molybdenum for reserve conversion purposes at USD10/lb and 85% payability. To test the sensitivity on potential reserve size, it was excluded as a revenue generator in one of the initial Whittle analysis, and did not indicate a material impact.

## 15.4.7 Realization Charges

Revenue realization charges consist of the following:

- Copper deductions.
- Gold deductions.
- Copper treatment costs.
- Copper refining costs.
- Concentrate handling charges.
- Weight franchise deductions.
- Royalties and mining levies.

It should be noted that treatment and refining charges are negotiated annually, and differ for each mine. As such, previous feasibility studies and market benchmarks were used to determine acceptable rates. It is not expected that a variation in these estimates will materially misstate the project valuation. The Whittle sensitivity proved potential reserve size to be very insensitive to changes in these parameters.

During the Whittle analysis, changes occurred in the copper treatment costs, copper refining costs and concentrate handling costs.

### 15.4.7.1 Copper Deductions

Copper deductions are calculated by multiplying the copper revenue by the copper payable scale. The copper payable scale applied in the Whittle analysis was obtained from an FS of a copper-gold deposit in PNG and is illustrated Table 15-9.





**Table 15-9: Copper Payable Scale**

Copper in Concentrate	Payable Scale
26%	96.10%
27%	96.20%
28%	96.30%
29%	96.40%
30%	96.50%
33%	96.60%
35%	96.65%
40%	96.70%

The equation used for the above is shown below:

$$(1 - \text{Payable Scale}) \times \text{Cu kt}$$

$$\text{Above calculations} \times \text{Cu Price} \times 2\,205 \div 1\,000 = \text{Cu deduction (R'm)}$$

### 15.4.7.2 Gold Deductions

Gold deductions are calculated by applying a gold payable scale. The gold payable scale used during the Whittle analysis was obtained from an FS of a copper-gold deposit in PNG and is illustrated in Table 15-10.

**Table 15-10: Gold Payable Scale**

Gold in Concentrate (g/t)	Payable Scale
1	0.00%
3	90.00%
5	95.00%
10	96.00%
20	97.00%
30	97.25%
40	97.50%
50	98.00%
75	98.25%

The equation used for the above is shown below:

$$(1 - \text{Payable Scale}) \times \text{Gold koz} \times \text{Gold Price} \div 1000 = \text{Gold deduction (R'm)}$$



### 15.4.7.3 Copper Treatment Costs

During the Whittle analysis prior to review of this input parameter, the Wood Mackenzie benchmark rate of USD94.10/t (real) of copper concentrate was applied.

Three sources of treatment costs were obtained for the study. Wood Mackenzie provided a benchmarked rate of USD94.1/t of copper concentrate and a recent FS of a copper-gold deposit in PNG applied a rate of USD80/t of copper concentrate. UBS, however, noted supply disruption in the sector, which is expected to negatively influence concentrate trade; UBS, therefore, decreased its benchmarked rate from USD90/t to USD60/t. UBS is a Swiss global financial services company.

A rate of USD80.00/t was selected for the purposes of this study and was applied in the updated Whittle analysis instead of USD94.10/t of concentrate.

### 15.4.7.4 Copper Refining Costs

Wood Mackenzie's benchmarked rate of USD0.0941 per copper pound was applied in the Whittle analysis prior to review of this input parameter. A recent FS of a copper-gold deposit in PNG applied a rate of USD0.08 per copper pound. The value of USD0.08/lb was selected for the updated Whittle analysis in the light of UBS' view on supply disruptions.

### 15.4.7.5 Concentrate Handling Charges

During the Whittle analysis prior to review of this input parameter, concentrate handling charges related to ocean export freight costs to the amount of USD29.30 per wet metric tonne of concentrate were applied. The rate was obtained from a recent FS of a copper-gold deposit in PNG.

The Sentient Group's experience with concentrate sales indicate that the majority of contracts are negotiated on FOB shipping terms. Concentrate handling charges relating to ocean export freight costs have therefore, not been considered during the Whittle analysis for this study.

### 15.4.7.6 Weight Franchise Deductions

Bill of loading cost (weight franchise deductions) was applied at a rate of 0.25% of total revenue. The rate was obtained from a recent FS of a copper-gold deposit in PNG.

## 15.4.8 Opex for Whittle Inputs

This section serves to document the preliminary operating costs used as Whittle inputs for the PFS.

### 15.4.8.1 Basis of Estimate

The Preliminary Opex estimate was prepared to provide operating costs per ore type (oxide, mixed/transitional and sulphide) for processing and the associated mine infrastructure. This estimate includes the cost of crushing and mine dewatering. The initial operating cost for mining was based on a previous FS done on Yandera and was escalated to 2017 terms. This cost was revised in later Whittle analysis, based on the methodology described in Section 15.4.8.5.



The estimate was prepared using the following methodology:

The basis of the concentrator operating cost was the estimate prepared by Arccon Mining Services, titled 5298 Yandera Project, Feasibility Study Operating Cost Estimate Rev E, in 2012. This estimate was modified to align with the current project scope, which was 45Mtpa at the time of the initial Whittle analysis, with oxide ore treatment and tailings disposal via DSTP. Historical rates were escalated to January 2017 terms.

The detailed calculations and assumptions supporting this estimate are contained in the following files:

- Yandera PFS Prelim Opex.
- Yandera FS Opex – Rev E\_45Mtpa.
- Yandera Diesel Cost – Prelim Whittle Inputs.

Costs relating to mine infrastructure were used from the StepWise study prepared by Advisian in 2016 and escalated to January 2017 terms.

### 15.4.8.2 Diesel Price

The diesel price was calculated assuming that diesel is purchased in Madang and transported by bulk road tanker to Banu ( $\pm 100$ km). Diesel will be offloaded at Banu into storage tanks and pumped from there to storage tanks at the Yandera mine site.

**Table 15-11: Diesel Supply Cost at Yandera**

Description	Value	Units
Landed Cost in Madang	0.81	USD/ℓ
Road Transport Cost (100km)	0.04	USD/ℓ
Pumping Cost (Power and Maintenance)	0.02	USD/ℓ
<b>Total</b>	<b>0.87</b>	<b>USD/ℓ</b>

### 15.4.8.3 Operating Costs – Processing and Infrastructure

The processing operating costs are made up of the following elements:

- Reagents and Consumables.
- Power.
- Labour.
- Maintenance.
- Miscellaneous.

**Table 15-12: Operating Cost per Tonne**

Opex, Processing and Infrastructure	USD/t treated
Oxide Ore	6.83
Sulphide and Mixed Ore	7.46
Molybdenum add-on	0.09



#### 15.4.8.4 Mining Operating Costs

The basis of the mining operating cost used initially in the Whittle pit optimization process was the estimate prepared by Mining One Consultants as part of the Marengo Mining Limited report, titled Yandera Copper – Molybdenum – Gold Project, 30Mtpa Feasibility Study Report, in 2012. This was escalated to 2017 terms.

The average LoM mining operating cost that included Drilling, Blasting, Loading, Haulage, Auxiliary Equipment, Grade Control, Labour, Dewatering and Mining Related Fixed Costs, was USD2.76/t mined. The initial revised rates are shown in the table below:

**Table 15-13: Operating Cost per tonne**

Original Rate	CPI Base Index (Dec 2012)	Jan 2017 CPI Index	Revised Rate
2.76	229.594	242.839	<b>USD2.92</b>

The revised rates were calculated as follows:

$$\text{Original rate} \div \text{Base Index} \times \text{Jan 2017 Index} = \text{Revised Rate}$$

#### 15.4.8.5 Revision of Mining Operating Costs applied in Whittle

This section summarizes the assumptions, which were applied to obtain the appropriate operating costs (Opex) rate for the Whittle analysis.

Although the information provided is deemed to be sufficient for NI 43-101 purposes, the inputs were revised during the PFS as more accurate information became available and was found to be within 5% of the final mining operating costs for the owner-operated scenario.

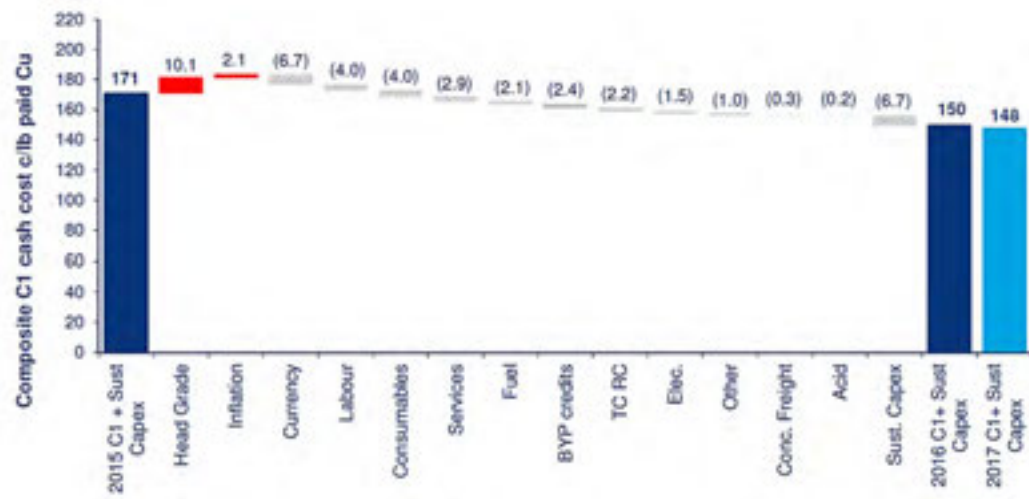
Cost estimators generally apply escalation factors when using cost rates that are older than one year. CPI, Producer Price Index (PPI) and mine cost indices are examples of sources that are used when calculating escalation rates. A consolidation of Wood Mackenzie reports, however, showed that the copper mining industry has experienced cost deflation over the past five years (2012 to 2016) rather than cost inflation.

The Wood Mackenzie analysis applied C1 costs and consolidated all copper mines in its database. There are two possible shortcomings in this analysis. Firstly, it analyses C1 costs, which include non-mining operating costs. Secondly, it could be argued that global average cost fluctuations do not necessarily apply to mines in PNG. The Wood Mackenzie results, therefore, could not be applied directly to the Yandera mine in PNG. An independent analysis was performed to calculate these fluctuations in a PNG mining environment.



### 15.4.8.5.1 Original Wood Mackenzie Analyses

The Wood Mackenzie reports and analyses from 2012 to 2016 were investigated as the previous FS was completed in 2012. An example of a single year's fluctuations is illustrated in Figure 15-4 below.



**Figure 15-4: Wood Mackenzie Cost Analysis**

A consolidation of the 2012 to 2016 analyses is shown in Table 15-14 below:

**Table 15-14: 5-year Aggregate Wood Mackenzie Analysis**

Original Rate	2012-13	2013-14	2014-15	2015-16	Aggregate
<b>2012 C1 + Sustaining Capex</b>	<b>188.32</b>				
<b>Opening Balance C1 + Sustaining Capex</b>		<b>191.74</b>	<b>185.69</b>	<b>171.41</b>	<b>188.32</b>
Head Grade	-5.75	3.15	8.73	10.10	16.23
Fuel	-0.41	-0.97	-3.29	-2.10	-6.76
Acid	-1.03	-0.18	-0.21	-0.20	-1.62
Elec.	-1.45	-0.76	-0.24	-1.50	-3.94
Labour	0.44	-1.13	-5.19	-4.00	-9.88
Consumables	-1.88	-0.80	-3.95	-4.00	-10.63
Services	-3.60	-1.05	-3.03	-2.90	-10.58
Inflation	0.21	-1.40	4.25	2.10	5.17
Currency	-4.86	-11.14	-14.19	-6.70	-36.89
Other	10.67	9.30	0.32	-1.00	19.28
Conc. Freight	0.38	-0.18	-0.64	-0.30	-0.74
TC RC	0.15	1.78	0.43	-2.20	0.16
BYP credits	6.48	0.64	4.69	-2.40	9.41
Sustaining Capex	4.07	-3.31	-1.98	-6.70	-7.91
<b>Closing Balance C1 + Sustaining Capex</b>	<b>191.74</b>	<b>185.69</b>	<b>171.41</b>	<b>149.61</b>	
<b>2016 C1+ Sustaining Capex</b>					<b>149.61</b>



Table 15-14 shows continuous cost deflation from 2012 to 2016 and categorises these fluctuations according to numerous activities or influencing factors. The following influencing factors will not be relevant to the Yandera study mining operating costs:

- Head Grade Yandera’s grade will not be influenced by global averages.
- Acid Acid is a processing-related cost.
- Other The report does not indicate which costs are classified as “Other”.
- Conc. Freight Not relevant to mining costs.
- TC RC Treatment and refining is not relevant to mining Opex.
- BYP Credits By-product credits are not relevant to mining Opex.
- Sustaining Capex Sustaining capital is not relevant to mining Opex.
- Electricity No electricity costs were included in the 2012 FS rate.

The following fluctuations are relevant to the Yandera study and were independently recalculated to ensure that the fluctuation is applicable to a PNG mining operation:

- Fuel.
- Labour.
- Consumables.
- Services.
- Inflation.
- Currency.

#### 15.4.8.5.2 Yandera Opex Analysis

The sections below explain the adjustments that were made to the 2012 mine Opex rate of USD2.76/t. Mine Opex rates are provided in Table 15-15. As described above, fuel, labour, consumables, services, inflation and currency related inputs are relevant to mining Opex. Fuel adjustments were assessed separately from other cost inputs and labour, consumables and services related adjustments were combined in the inflation and currency adjustment sections.

**Table 15-15: Yandera 2012 Mine Opex Rates**

Mine Opex Cost Activity	USD/t
Drilling	USD0.17
Blasting	USD0.40
Loading	USD0.25
Haulage	USD0.78
Auxiliary	USD0.64
Grade Control	USD0.09
Labour	USD0.33
Dewatering	USD0.04
Fixed Costs	USD0.06
<b>Total</b>	<b>USD2.76</b>



### 15.4.8.5.2.1 Fuel Adjustments

According to the US Energy Information Administration (EIA), more than 63% of the cost of fuel is driven by crude oil prices (EIA, 2016). The remaining influencing factors relate to a combination of taxes, refining, distribution and marketing expenses.

The current (2017) delivered price of fuel for the Project was calculated at USD0.87/ℓ, which is a 29.8% decrease from the 2012 study (USD1.24/ℓ). Although the fuel price decreased, it is expected that the long-term real fuel price will not remain at this level. A consensus forecast (Knoema, 2017) was therefore obtained to determine an appropriate long-term real cost rate (see Table 15-15).

**Table 15-16: Long-term Crude Oil Price Forecast (USD/barrel)**

Item	2017	2018	2019	2020	2021	2022	2023	2024	2025
World Bank	55.0	60.0	61.5	62.9	64.5	66	67.6	69.3	71.0
IMF	55.2	55.1	54.1	54.0	54.4	55.2			
OECD	45.0	45.0							
EIU	56.0	60.0	59.9	61.3	64.0				
<b>Nominal Average</b>	<b>52.8</b>	<b>55.0</b>	<b>58.5</b>	<b>59.4</b>	<b>61.0</b>	<b>60.6</b>	<b>67.6</b>	<b>69.3</b>	<b>71.0</b>
<b>Cumulative US CPI</b>	<b>1</b>	<b>1.02</b>	<b>1.04</b>	<b>1.06</b>	<b>1.08</b>	<b>1.1</b>	<b>1.13</b>	<b>1.15</b>	<b>1.17</b>
<b>Real Average</b>	<b>52.8</b>	<b>54.0</b>	<b>56.2</b>	<b>56.0</b>	<b>56.3</b>	<b>54.9</b>	<b>60.0</b>	<b>60.3</b>	<b>60.6</b>

Table 15-16 shows that the 2017 average crude oil price will increase by 14.77% to reach the long-term real price of USD 60.6 per barrel [ $\text{USD } 0.6 \div \text{USD } 52.8 = 14.77\%$ ]. When applying the crude oil price escalation to the 2017 fuel price of USD0.87/ℓ, the long-term real fuel price will increase to USD1.0/ℓ. This represents a 19.35% decrease when compared to the 2012 fuel price of USD1.24/ℓ [ $\text{USD } 1.24 - \text{USD } 1.0 \div \text{USD } 1.24 = 19.35\%$ ].

Thirty-three percent of the mining Opex rate (USD2.76/t) related to fuel consumption and when applying a 19.35% decrease in fuel costs, the cost per tonne decreases by USD0.176 [ $19.35\% \times 33\% \times \text{USD } 2.76 / \text{t} = \text{USD } 0.176 / \text{t}$ ].

### 15.4.8.5.2.2 Currency Adjustment

The US dollar has strengthened in value against the PNG Kina (PGK) over the past five years, and this strengthening resulted in cost deflation of locally procured goods and services. Table 15-17 illustrates which cost activities and elements are expected to be incurred in PGK. In total, 21.5% of all mine Opex will be incurred locally.

**Table 15-17: Local (PNG) Spend Analysis**

Cost Category	Cost Elements	% Local Spend	Local Spend Contribution
Labour*	All labour categories	100%	12%
Drilling	Maintenance, Abuse Repair, Consumables	20%	1%
Blasting	Accessories	20%	3%
Loading	Maintenance, Accident Abuse	20%	1%
Haulage	Maintenance, Accident Abuse	20%	2%





Cost Category	Cost Elements	% Local Spend	Local Spend Contribution
Auxiliary	Maintenance, Accident Abuse	20%	2%
Dewatering	All dewatering categories	20%	0.3%
Grade Control	Drilling, Consumables	20%	1%
			<b>21.5%</b>
* 15% of labour relates to minimum waged employees (~2% contribution of total Opex rate)			

Table 15-18 illustrates the PGK: USD exchange rate between 2012 and 2016 (XE, 2017). The table shows that the US dollar strengthened by 11.2% per year, or 56% over the 5-year period.

**Table 15-18: PGK:USD Exchange Rate**

Item	Units	2012	2013	2014	2015	2016
PGK : USD (XE.com)	Rate	2.07	2.50	2.65	2.99	3.17
<b>Compound Annual Growth Rate</b>	<b>%</b>					<b>11.2%</b>

A 56% reduction in local operating costs amounts to a USD0.33/t saving.

$$(56\% \times 21.5\% \times \text{USD}2.76 = \text{USD}0.33/\text{t})$$

#### 15.4.8.5.2.3 Inflation Adjustment

The Wood Mackenzie analysis in Table 15-14 shows an increase in costs due to inflation-related increases. This inflation adjustment is not necessarily linked to CPI, but rather to a mining cost index. The assumption was made that global supply and demand related fundamentals could have influenced the cost of labour, consumables, spares and other related costs. The 5-year Wood Mackenzie average was, therefore, applied to Yandera.

The aggregate column in Table 15-14 shows that costs increased by USD5.17 due to inflationary factors. USD5.17 amounts to 2.7% of the total 2012 Wood Mackenzie cost rate of USD188.32 ( $\text{USD}5.17 \div \text{USD}188.32 = 2.7\%$ ).

The PFS cost rate will increase by USD0.08/t when applying this inflationary increase ( $2.7\% \times \text{USD}2.76 = \text{USD}0.08/\text{t}$ ).

A portion of the total cost, rate, however relates to minimum wage labour. PNG's minimum wage increased by 41% in 2014 (Trading Economics, 2017a) and is expected to increase by 60.4% when calculating the increase over the past five years (Trading Economics, 2017b). The PNG minimum wage for the past five years is shown in Table 15-19.

$$[(\text{PGK } 146 \div \text{PGK } 91) - 1 = 60.4\%]$$

**Table 15-19: Papua New Guinea Minimum Wages**

Item	Units	2012	2013	2014	2015	2016
PGK/week	PGK	91	128	134	140	146



The minimum wage escalation will increase the PFS costs by USD0.03/t

$$(US0.33/t \text{ labour rate} \times 15\% \times 60.4\% = \text{USD}0.03/t).$$

This increase can however, only be considered when first removing minimum wages from the USD0.08/t above. The removal of the 15% minimum wage will decrease the USD0.08/t value to USD0.07/t.

$$[2.7\% \times \text{USD}2.76 \times (100\% - (\text{USD}0.33/t \times 15\%)) = \text{USD}0.07/t]$$

The final recalculated inflation adjustment, therefore, amounts to USD0.10/t (USD0.07 + USD0.03 = USD0.10).

The revised operating cost rates for the Whittle analysis are summarized in Table 15-20.

**Table 15-20: Revised Mining Opex for Whittle**

Mine Opex Cost Activity	USD/t
<b>Original 2012 Feasibility Study Rate</b>	<b>USD2.76/t</b>
Fuel adjustment (see Section 3.1)	-USD0.18/t
Currency adjustment (see Section 3.2)	-USD0.33/t
Inflation adjustment (see Section 3.3)	+USD0.10
<b>Revised Mining Opex for Whittle</b>	<b>USD2.36/t</b>

## 15.4.9 Basis for Recovery Prediction for Whittle Pit Optimization

This section provides the basis for recovery estimates used for Whittle modelling.

### 15.4.9.1 Recovery Predication Philosophy

Recovery estimates were prepared for an FS executed in 2011, and were based on metallurgical test work conducted by ALS during this time. The test work programme and results are presented in detail in the following test work report:

- Report A13914:- Metallurgical Test work conducted upon Ore Samples from the Yandera Copper-Molybdenum Project for Marengo Mining Limited.

Recoveries were predicted by material type for each of the target zones. The target zones investigated were Gremi, Omora and Imbruminda. The material types investigated were oxide, mixed (transitional) and sulphide (referred to as Hypogene). It is important to note that:

- The 2011 study excluded oxide processing as part of the Project; this has been re-included for consideration (oxide flotation) and, therefore, a benchmarked blanket recovery estimate has been used for the Whittle analysis.
- The 2011 study did not include estimates for Dimbi and Gamagu and so benchmarked figures from the surrounding pits will be used for this estimate.



### 15.4.9.2 Copper Recovery Estimate

Copper recovery estimates are based on:

- Oxide material: Limited test work was conducted on the oxide material, as the original intention was not to process this ore. The recovery estimate for the Whittle analysis, therefore, is a flat recovery based on available test work.
- Mixed material: Limited test work was conducted on samples of varying S:Cu ratios on Omora and Gremi ore; low-grade global mixed composite test work results were also used.
- Sulphide material: Regression analysis was conducted on the results of cleaner and locked cycle test work campaigns in order to produce correlations between Cu head grade and Cu recovery. Cu recovery to the sulphide zone shows little dependence on Cu head grade, with exception of very low grades; a cap of 95% has been applied to the regression equations. This Cu recovery has been benchmarked against similar deposits.
- Dimbi deposit:-As no metallurgical test work has been conducted on the Dimbi deposit yet, the Cu recovery of this deposit was assumed similar to those of Imbruminda.
- Scale-up: A recovery de-rating of 2% has been applied to the calculations to make provision for scaling up from metallurgical test work to full-scale plant operation. The de-rated recovery values should be used for Whittle inputs in all cases.

Recovery predication algorithms are presented in Table 15-21 and Table 15-22. This presents the recovery projections excluding and including a 2% de-rating for scale up to plant operations.

**Table 15-21: Cu Recovery Prediction Algorithms, excluding the 2% De-rating for Scale –up**

Ore Type	Target Zone/Deposit	Recovery Predication (%) Based on Test work	Source Information
Oxide	All zones	60%*	Based on results obtained during optimization studies, specifically tests GS6716 and GS6717.
Mixed	Gremi	82%	Mixed ore test work on various Gremi samples refer to tests RDA653 to RDA663 (11 tests). Refer to Table 5.20 in Section 5 of the 30Mtpa Feasibility Study report, as associated rationale
	Omora	58%	Refer to Figure 5.12 and Table 5.21 in Section 5 of the 30Mtpa Feasibility Study report, as associated rationale.
	Imbruminda	75%	Average of single locked cycle test on Imbruminda mixed sample, as well as locked cycle work on global mixed composites. Insufficient information to derive a grade/recovery correlation.



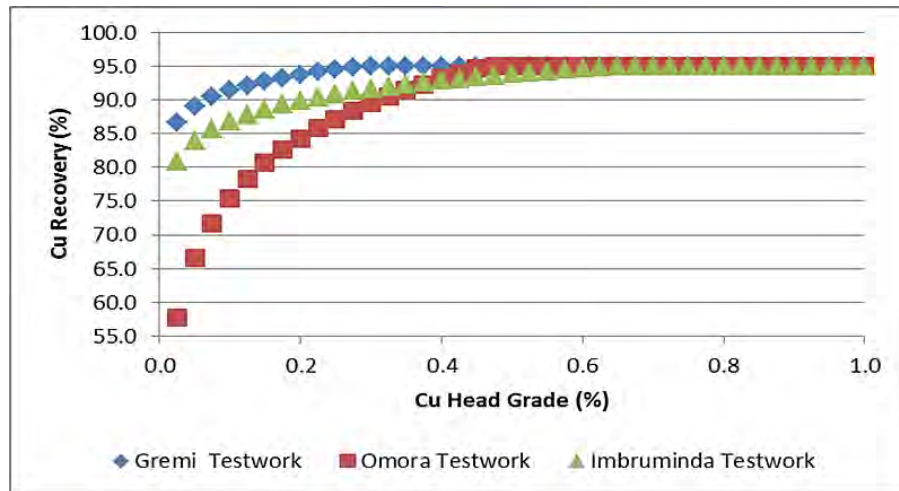
Ore Type	Target Zone/Deposit	Recovery Predication (%) Based on Test work	Source Information
	Dimbi	As per Imbruminda	Assumption
Sulphide	Gremi	$R = 3.3876 * \ln(\text{Cu head grade}) + 99.135$ , capped at 95%	Refer to Figure 5.2, Section 5 of the 30Mtpa Feasibility Study report. Based on cleaner and locked cycle results for three samples
	Omora	$R = 12.766 * \ln(\text{Cu head grade}) + 104.82$ , capped at 95%	Refer to Figure 5.4, Section 5 of the 30Mtpa Feasibility Study report. Based on cleaner and locked cycle results for nine samples
	Imbruminda	$R = 4.3275 * \ln(\text{Cu head grade}) + 96.809$ , capped at 95%	Refer to Figure 5.3, Section 5 of the 30Mtpa Feasibility Study report. Based on cleaner and locked cycle results for nine samples
	Dimbi	As per Imbruminda	Assumption

\* This assumes a concentrate grade of 20%, if a higher-grade concentrate (25%) is to be produced; recovery estimates are adjusted to 55%.

**Table 15-22: Cu Recovery Prediction Algorithms, including the 2% De-rating for Scale-up**

Ore Type	Target Zone/Deposit	Recovery Predication (%) Based on Test work
Oxide	All zones	58%
Mixed	Gremi	80%
	Omora	56%
	Imbruminda	73%
	Dimbi	As per Imbruminda
Sulphide	Gremi	$R = 3.3876 * \ln(\text{Cu head grade}) + 97.135$ , capped at 93%
	Omora	$R = 12.766 * \ln(\text{Cu head grade}) + 102.82$ , capped at 93%
	Imbruminda	$R = 4.3275 * \ln(\text{Cu head grade}) + 94.809$ , capped at 93%
	Dimbi	As per Imbruminda

The Cu recovery vs head grade correlations for sulphide ore based on metallurgical test work are presented in Figure 15-5.



**Figure 15-5: Cu Grade Recovery Correlation-Sulphide Ore (excludes de-ration)**

### 15.4.9.3 Gold Recovery Estimate

Gold recovery estimates are based on the results obtained from the variability programme, bulk flotation work on the C1-8 composite series as well as locked cycle test work conducted. The data were used to establish correlations between Au recovery and Au head grade. It should be noted that as the final mass pulls to some of the stages were very low, certain of the samples could not undergo Au assay, and the implication of this is that insufficient data were available for recovery by grade predictions for the following materials:

- Oxide ore types (all).
- Mixed ore types (all).
- Omora deposit.

Flat recovery estimates have been supplied for these deposits using the available information. Recovery predictions are presented in Table 15-23 and Table 15-24.

**Table 15-23: Au Recovery Prediction Algorithms, excluding the 2% De-rating for Scale-up**

Ore Type	Target Zone/Deposit	Recovery Prediction (%) Based on Test Work	Source Information
Oxide	All zones	50%	Locked cycle test work on a low-grade oxide sample (0.58%Cu) – refer to test RDA594.
Mixed	All zones	70%	Bulk flotation test work on locked cycle testing on a low-grade (0.32% Cu) mixed ore sample (Sample 2B) - refer to test RDA 664. The sample was a global composite.
Sulphide	Gremi	$R = 26.692 \cdot \ln(\text{Au head grade}) + 133.46$ , Au grade < 0.4g/t Capped to a maximum of 83%.	Refer to Figure 5.15, Section 5 of the 30Mtpa Feasibility Study report. Based on cleaner and locked cycle results for five samples
	Omora	64%	Refer to locked cycle test work on a low-grade Omora sample (0.38%Cu), test RDA 596

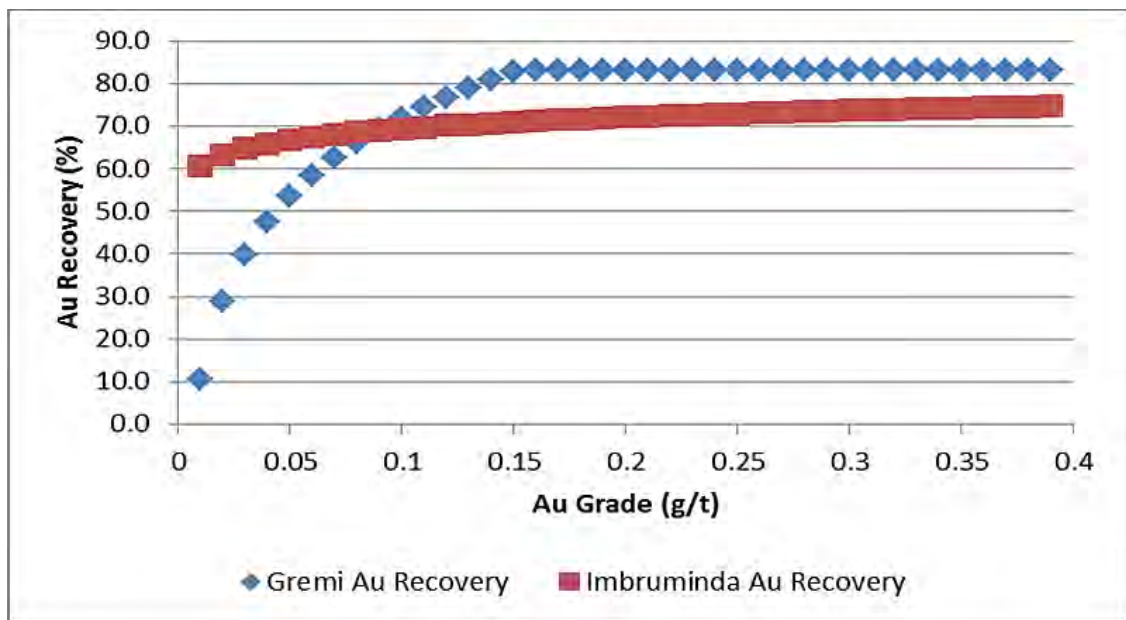


Ore Type	Target Zone/Deposit	Recovery Predication (%) Based on Test Work	Source Information
	Imbruminda	$R = 3.8636 \cdot \ln(\text{Au head grade}) + 78.334$ Capped to a maximum of 83%.	Refer to Figure 5.16, Section 5 of the 30Mtpa Feasibility Study report. Based on cleaner and locked cycle results for seven samples
	Dimbi	As per Imbruminda	Assumption

**Table 15-24: Au Recovery Prediction Algorithms, including the 2% De-rating for Scale-up**

Ore Type	Target Zone/Deposit	Recovery Predication (%) Based on Test work
Oxide	All zones	48%
Mixed	All zones	68%
Sulphide	Gremi	$R = 26.692 \cdot \ln(\text{Au head grade}) + 131.46$ , Au grade < 0.4g/t Capped to a maximum of 81%.
	Omora	62%
	Imbruminda	$R = 3.8636 \cdot \ln(\text{Au head grade}) + 76.334$ Capped to a maximum of 81%.
	Dimbi	As per Imbruminda

The Au recovery vs head grade correlations for sulphide ore based on metallurgical test work are presented in Figure 15-6.



**Figure 15-6: Au Grade Recovery Correlation-Sulphide Ore (excludes de-ration)**



#### 15.4.9.4 Mo Recovery Estimate

Mo recovery estimates are limited to a flat estimate because of limited test work data, and as correlation between Mo recovery and Mo head grades was poor, based on the previous test work data. Although variability samples were tested, these were conducted in open circuit and, therefore, are not appropriate for recovery estimation or prediction. The predictions are based on the locked cycle test work conducted in 2011/2012.

Recovery predictions are presented in Table 15-25.

**Table 15-25: Mo Recovery Prediction Algorithms, including the 2% De-rating for Scale-up**

Ore Type	Target Zone/Deposit	Recovery Prediction (%) Based on Test work
Oxide	All zones	55%
Mixed	All zones	69%
Sulphide	Gremi	67%
	Omora	64%
	Imbruminda	67%
	Dimbi	As per Imbruminda

#### 15.4.9.5 Whittle Process Recovery Prediction Conclusion

The recovery prediction formulas were limited to available test work data and were to be used for preliminary Whittle runs to determine the ultimate pit shell geometry on which the pit design is based. The prediction equations were revised upon completion of variability test work during the 2013 FS.

### 15.5 Concentrate Grade Prediction

The concentrate grade prediction is important. It is used in conjunction with the Realisation Charges and is to be applied to Mo deductions, and is used to determine the mass pulls to be applied to treatment costs, refining costs, concentrate handling charges and weight franchise deductions later determined to be relevant. Currently the Mo concentrate grade is estimated at 50% in the form of MoS<sub>2</sub>. Payability is assumed 85% until confirmation can be obtained. This is in line with the payability applied in the Yandera Copper-Molybdenum-Gold Project 30Mtpa Feasibility Study Report of 2012 and, as such, the molybdenum concentrate transport cost from the same report will have to be applied in the Whittle analysis. This amounts to USD255/wmt Mo concentrate.

Proposed final concentrate grades and their basis are presented in Table 15-26.





**Table 15-26: Final Concentrate Grades and their Basis**

Ore Type	Element	Concentrate Grade Prediction	Comment
Oxide	Cu	20%	2011metallurgical test work programme and validated by benchmark information from similar operations
	Au	5g/t	Calculated, based on mass pull to concentrate (Cu based) and Au recovery for average LoM Au grade.
Sulphide	Cu	28%	2011metallurgical test work programme, based on the results attained for the Omora deposit, which has high chalcopyrite and pyrite concentrate.
	Au	5g/t	Calculated, based on mass pull to concentrate (Cu based) and Au recovery for average LoM Au grade.

## 15.6 Moisture Content

The moisture content of the concentrate is assumed approximately 10%, based on filtration test work experience with similar concentrate samples. The concentrate grades and moisture content are based on test work data and benchmark data.

## 15.7 Geotechnical Considerations

### 15.7.1 Preliminary Geotechnical and Geohydrological Assessment

For the recommended slope design, two scenarios are possible based on different avenues of approach:

- Scenario 1:- Use the original Laubscher Mining Rock Mass Classification that does not have a specific modifying factor for groundwater condition and then apply a factor of safety of 1.5 for the design.
- Scenario 2: – Use the modified classification system done by Jackubec and Laubscher in 2000 that has an adjustment factor for groundwater conditions included in the classification and using a FoS of 1.

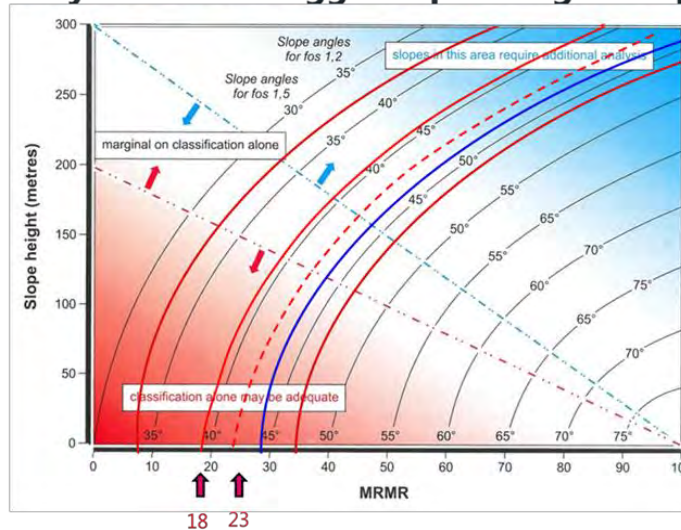
The maximum allowable slope angles were determined by using the maximum calculated average Mining Rock Mass Rating (MRMR) value in each case, 27 for Scenario 1 and 23 for Scenario 2. Figure 15-7 below was then used to determine and recommended an overall slope angle of 47°. The MRMR (1990) does not include groundwater as an adjustment. It is implied in the stress conditions. The groundwater conditions for the Yandera Project indicate that pore pressure and wet conditions exist. The rockmass model and slope recommendations do not include seismic risk, therefore the recommended design is based on a FOS=1.5.

The MRMR (2000) included groundwater as an adjustment. Adjustment for inflow and pressure adjustment =70% for intact rock and = 85% for weathered material, due to low transmissivities and known artesian conditions. The rockmass model and slope recommendations do not include seismic risk, therefore the recommended design is based on a FOS=1.2 (Aggressive approach). The recommended maximum allowable slope angle for the overall Pit slope is 47.



In subsequent analysis, sectorized zones and dewatered and non-dewatered scenarios was tested. This Slope Design Recommendation is for the initial Whittle run only. The aim of the initial Whittle run is to determine the size, depth and shape of the optimally sized viable open pit.

### Hayens & Terbrugge Slope Design Graph



**Figure 15-7: Recommended Maximum Overall Slope Angles -- Initial Whittle Run**

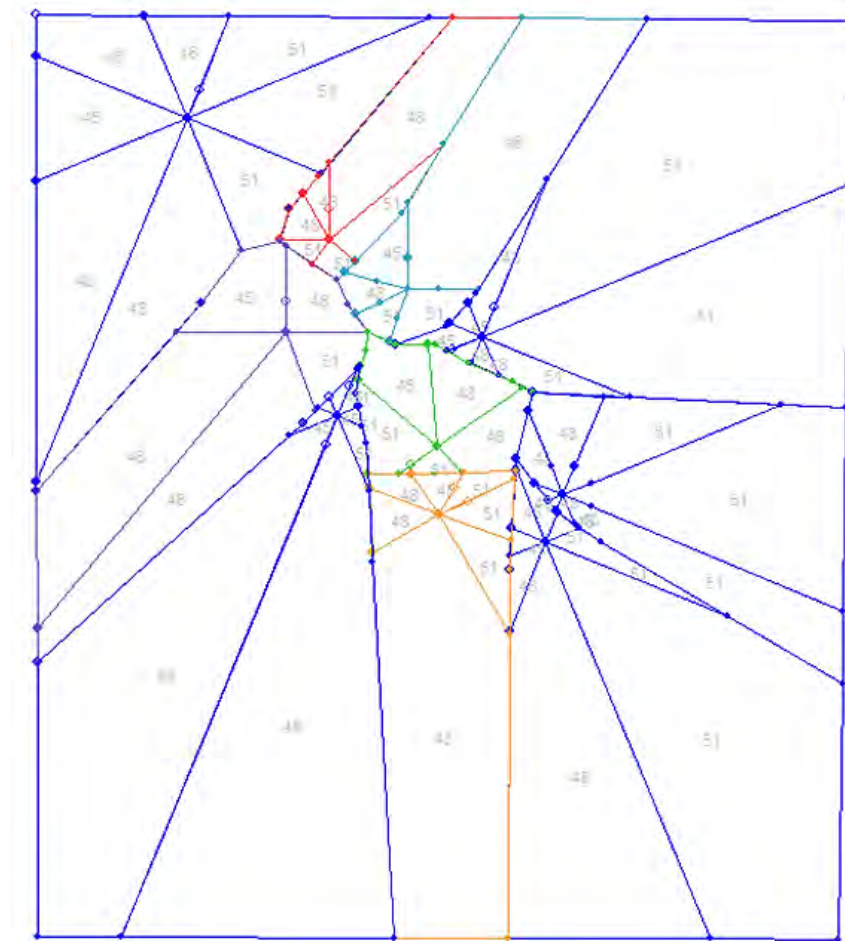
The initial Whittle run was used to establish the location and extent of the potential pit. This information was used to establish geotechnical sectoring, and detailed analysis was performed to determine the final geotechnical input parameters into the Whittle analysis.

The updated geotechnical sectoring and adjusted slope angles per sector are depicted in Figure 15-8 represent the complexity of the geotechnical inputs into the Whittle analysis and pit design processes.

Figure 15-8 was compiled and subsequently applied to the block model, from where the required slope angles were imported into Whittle.

In a next step, the slope angles in Whittle in relevant sectors were reduced to provide for the inclusion of haul roads and, in this way, limit the deviation of the initial pit design from the Whittle selected pit shell.

It also ensured that the Whittle economic analysis was done on the correct slope configuration and that the ultimate depth of the pit was based on close-to-the-correct final slopes, as provision for reduced slope angles caused by the addition of haul roads during the design process had already been taken into account to some degree.



**Figure 15-8: Yandera Geotech Slope Angles**

## 15.7.2 Design Principles

The slope configurations selected for the initial pit design were based on expected slope response in the wet, seismically active and structurally complex environment of Yandera. The design configuration assumes good drainage, good blasting practices and good slope management and control during mining.

Small-scale (bench scale) failures can be tolerated as access to all catch benches are planned to be maintained throughout the life of the pit to allow for clean-up and maintenance of the drainage network. The dewatering holes and horizontal drains are to be located on the catch benches.

The oxidized zone includes the overburden and Saprolite unit. It is expected that small-scale failures will occur; therefore, allowance is made for a substantial catch bench, 21m wide, at the base of the unit.



## 15.8 Whittle Analysis

A technical report disclosing mineral reserves must provide sufficient discussion and detail of the key assumptions, parameters and methods used for a reasonably informed reader to understand how the qualified person converted the mineral resources to mineral reserves.

The report must discuss the extent to which the Mineral Reserve estimates could be materially affected by mining, metallurgical, infrastructure, permitting and other relevant factors. As a Mineral Reserve estimate is based on many types of input data, an assessment of the sensitivity to these various inputs must form part of the estimation process.

Section 15.8 deals with the above NI 43-101 Reserve Estimate requirements.

### 15.8.1 Sequence of Steps to determine the Design Pit Shell

Subsequent to receipt of the geological block model and the MineSight pit shell that formed the basis of the Resource Estimate by SRK, the sequence as described below was followed, mainly using the Whittle 4.6 software, to arrive at a point where a pit shell was determined on which to base the initial pit design. In total, more than 55 Whittle iterations were performed in this analysis.

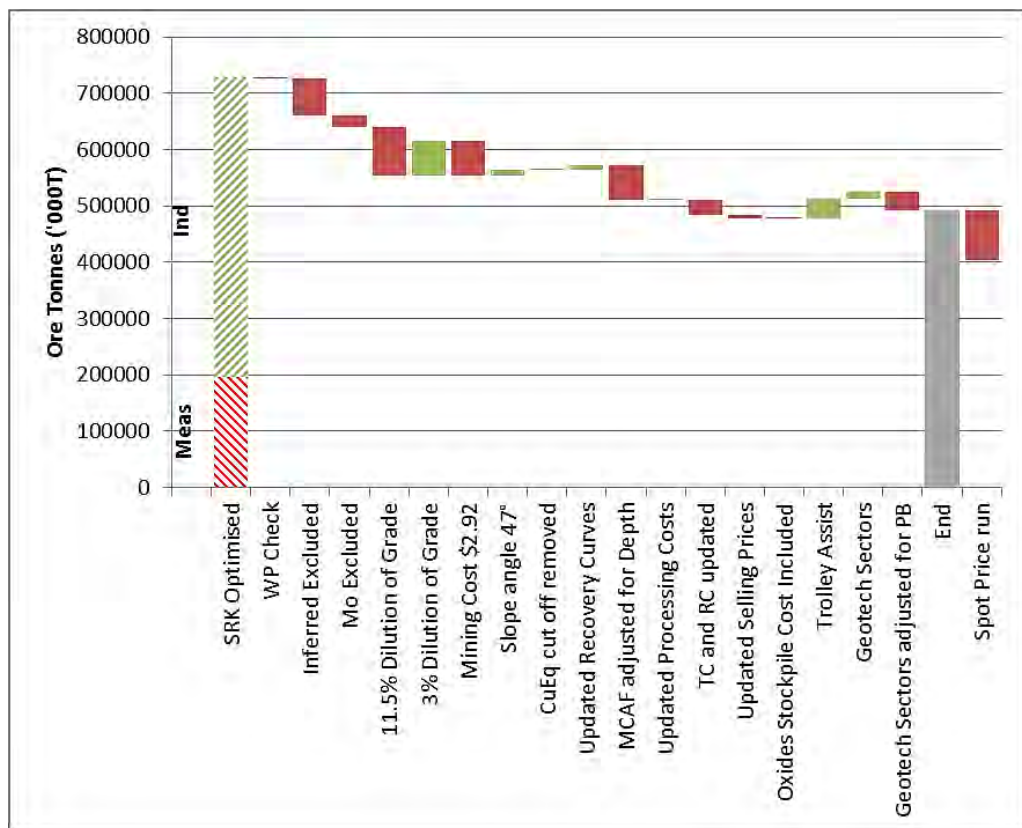
- Validation of Resource Estimate.
- Determination of mining losses already included in the geological block model, based on a reasonable sample size.
- Assessment of mining dilution to be included in the geological block model, based on a reasonable sample size.
- Determination of mining dilution to be applied to the geological block model for Reserve conversion.
- Whittle analysis without any contribution from Inferred Resources.
- Whittle analysis without any contribution from Mo until a market for MoS<sub>2</sub> concentrate could be verified.
- Test sensitivity when applying total required block model dilution.
- Apply recommended calculated mining dilution.
- Apply escalated mining cost (USD2.92/t).
- Apply initial overall slope angles (47°).
- Whittle analysis without using the 0.15% CuEq cut-off, as Whittle determines a variable economic cut-off per ore block.
- Apply updated recovery curves to the block model.
- Apply a Mining Cost Adjustment Factor (MCAF) to reflect the impact of increased mining depth on mining operating costs.
- Apply updated processing costs to the block model.
- Apply updated transport-, smelting- and refining costs, as well as net smelting and refining returns as PCAFs to oxide, sulphide and mixed ores.
- Apply the updated metal prices (only for Cu and Au, until Mo di-sulphide concentrate market and selling price could be confirmed).



- Apply a stockpiling and handling operating cost to oxide ore, to provide for rehandling at the end of the LoM.
- Perform sensitivity analysis on pit size and potential reserves (ore content) by altering Cu price, Au price, slope angles, mining cost, MCAF, mining dilution, TC & RC and processing recoveries for -20%, -10%, +10% and +20% adjustments. This amounted to 32 Whittle runs.
- Reduce mining operating costs and MCAF to consider the potential operating cost benefits of using trolley assist technology.
- Apply the updated geotechnical sectoring and adjusted slope angles.
- Reduce slope angles in Whittle in relevant sectors to provide for the inclusion of haul roads in the initial pit design.
- Analyse Whittle family of nested pits graphs to determine the pit shell on which to base the initial pit design.
- Re-run Whittle at current spot prices to quantify the difference in potential reserves when using the metal price forecasts established in this study as required by NI 43-101.

In addition to the process described above, a further Whittle sensitivity run was conducted to determine the impact of excluding oxide ore as a revenue generator. This was done to establish whether the oxide ore will add to the project value if stockpiled until the end of the LoM and then rehandled to be fed to the concentrator.

Figure 15-9 and Table 15-27 were derived from this analysis.



**Figure 15-9: Whittle Progression Waterfall Chart – M&I**



**Table 15-27: Whittle Analysis Progression based on M&I – Block Model tonnes**

Description	Block Model Potential Ore	Decrease (Increase)	Percentage Change
WP Check	726,886		
Inferred Excluded	660,971	65,915	-9%
Mo Excluded	639,377	21,594	-3%
11.5% Dilution of Grade	552,852	86,525	-14%
3% Dilution of Grade	616,216	(63,364)	11%
Mining Cost USD2.92	553,602	62,614	-10%
Slope angle 47°	563,773	(10,171)	2%
CuEq cut off removed	564,033	(260)	0%
Updated Recovery Curves	573,146	(9,113)	2%
MCAF adjusted for Depth	509,992	63,154	-11%
Updated Processing Costs	511,429	(1,437)	0%
TC and RC updated	483,888	27,542	-5%
Updated Selling Prices	477,246	6,642	-1%
Oxides Stockpile Cost Included	476,900	346	0%
Trolley Assist	512,585	(35,685)	7%
Geotech Sectors	524,370	(11,785)	2%
Geotech Sectors adjusted for PB	491,604	32,767	-6%
End	491,604	-	-
Spot Price run	403,812	87,791	-18%

## 15.8.2 Pit Size and Ore Tonnage Sensitivity Analysis

Sensitivity analyses were performed on pit size and potential reserves (ore content) by altering Cu price, Au price, slope angles, mining cost, MCAF, mining dilution, TC & RC and processing recoveries for -20%, -10%, +10% and +20% adjustments.

The results are depicted in Figure 15-10 and Figure 15-11 below.

Both the pit size and potential reserves are most sensitive to Cu price, processing recoveries and mining cost. Processing recoveries were capped on the positive side; therefore, the sensitivity is lower than on the negative side.

Both the pit size and the potential reserves are least sensitive for gold price, TC and RC and MCAF.



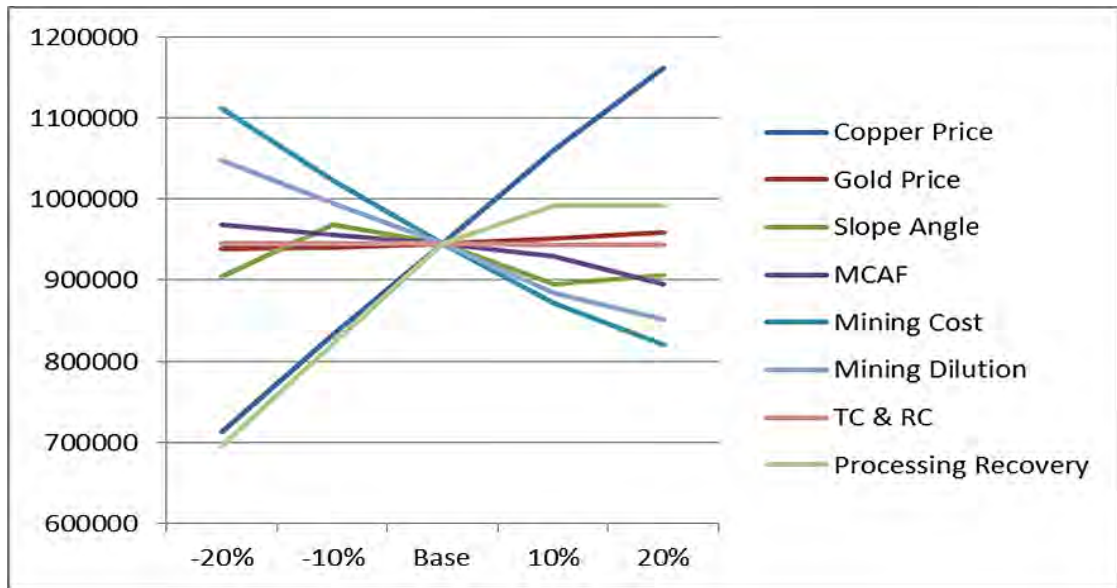


Figure 15-10: Yandera Whittle Sensitivity – Pit Size

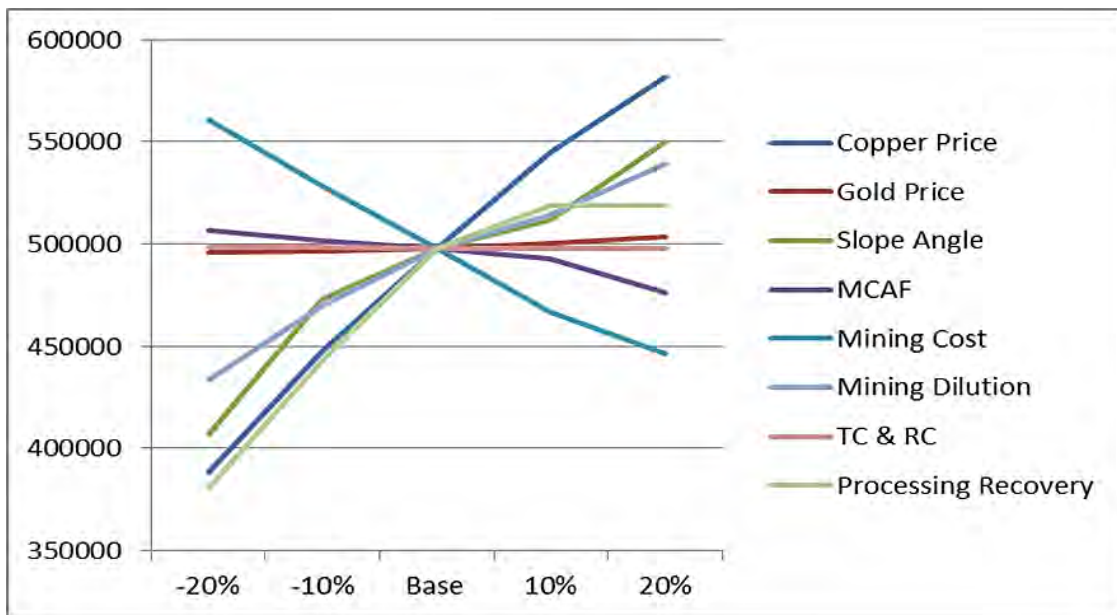


Figure 15-11: Yandera Whittle Sensitivity – Potential Reserve tonnage

### 15.8.3 Whittle Pit Shell Selection

The purpose of this section is to document the principles on which the decision to use Whittle Pit Shell 37 as the basis for the detailed pit design of the Yandera PFS were founded.

Subsequent to the sequence of steps described in Section 15.8.1, further Whittle iterations were conducted to include adjustments on treatment and refining costs, include Mo as a revenue generator, and adjust mining cost to the recalculated base and to adjust the MCAF.

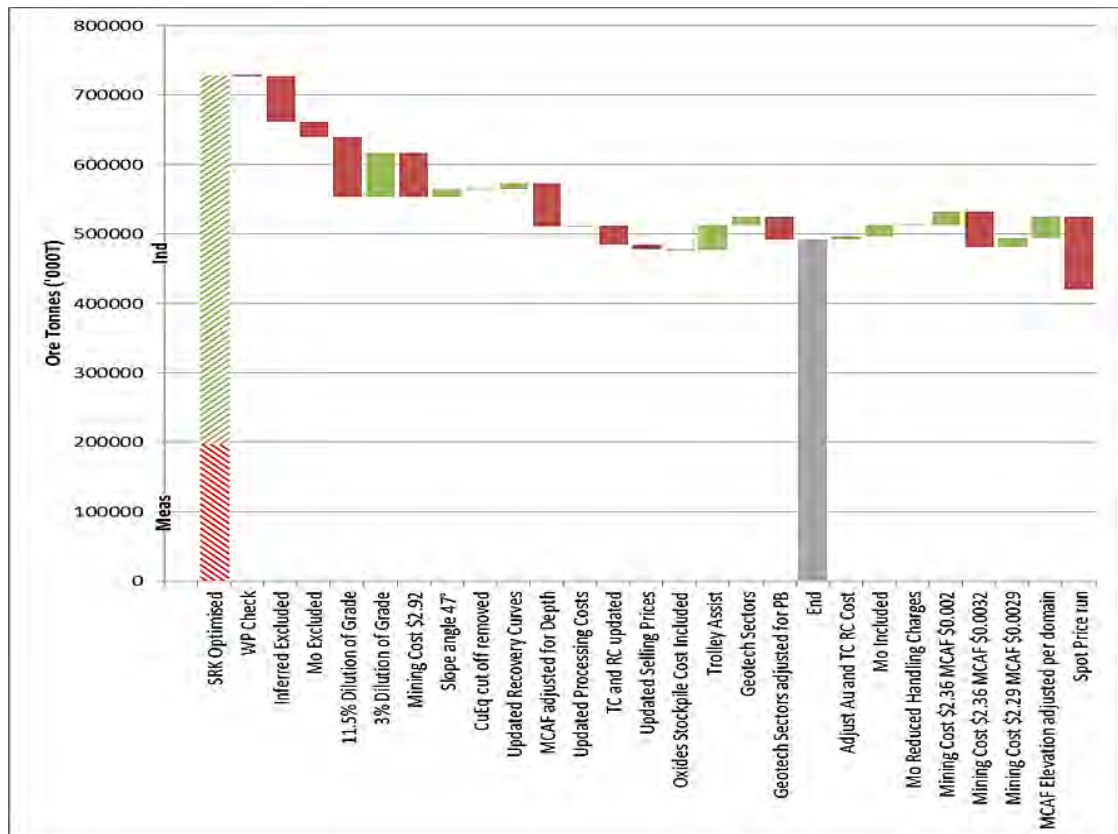
After completion of this process, the optimization methodology could be applied during the final Whittle analysis to incorporate locally diversified reference elevations to represent the exit point's characteristic of each of the main Yandera pits, in conjunction with the conceptual main haul road design to the crusher and waste rock dump locations.





Figure 15-12 below depicts the chronological sequence of adjustments made to the original Resource model to arrive at the Revenue Factor 1 Pit Shell 36 as described above. The result of the adjustments made to the MCAF reference elevation was an increase in potential ore tonnes from 494million, after inclusion of the trolley assist cost savings, to 524million.

The NI 43-101 process requires an evaluation at current spot prices. This was conducted at a copper price of USD2.53/lb, a gold price of USD1,260/oz and a molybdenum price of USD7.94/lb, and resulted in a pit shell representing 419Mt of potential reserves.



**Figure 15-12: Chronological Sequence of Whittle Analysis**

### 15.8.3.1 Final Whittle Analysis – Practical Reference Elevations

Prior to the MCAF optimization, the process followed to arrive at the pit shell depicting the optimal pit size and shape when applying the trolley assist technology was based on a mining operating cost of USD2.29/t mined and an MCAF of USD0.0029/m increase in depth below the reference elevation. The pit shell contained 494Mtof potential ore.

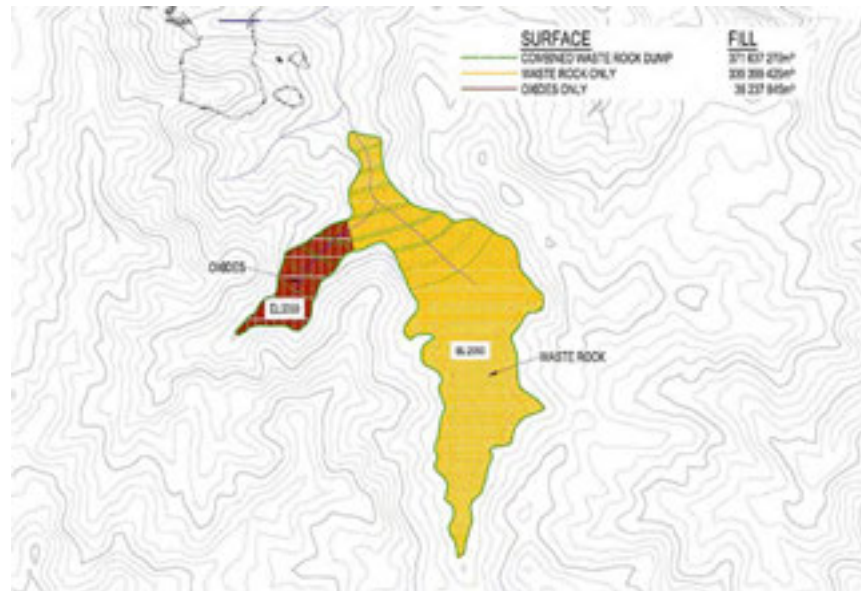
This was an increase from the pit shell before the incorporation of the cost benefits when applying the trolley assist technology. That pit shell was determined by using a mining operating cost of USD2.36/t and an MCAF of USD0.0032/m increase in depth below the reference elevation, and yielded 480Mtm potential ore.

The process followed up to the determination of the “Trolley Assisted” pit shell was appropriate, but further optimization was possible, specifically to determine the reference elevations from where the MCAF for each of the main pit areas of the Project, namely Gamagu, Imbruminda, Dimbi, Dimbi South, Gremi and Omora, was to be applied.



For the reference elevations to be at acceptable levels of accuracy, the waste rock dump location and elevation of the containment wall needed to be designed at conceptual level, as well as the main haul road, which was determined to be mainly horizontal at an elevation of 1800mamsl, the oxide ore stockpile location and the primary crusher location.

Figure 15-13 depicts the initial conceptual waste rock dump and oxide ore stockpile designs used in calculating the appropriate reference elevations.



**Figure 15-13: WRD and Oxide Ore Stockpile Designs**

The lowest exit elevations from the different pit locations prior to being transported to the crusher location, waste rock dump or oxide ore stockpile are shown in Figure 15-14.



**Figure 15-14: Pit Exit Reference Elevations**



The changes to final Whittle inputs, including the application of variable reference elevations, are shown in Table 15-28.

**Table 15-28: Yandera Whittle Inputs: Final Analysis**

Whittle Inputs	Quantity	Description
PCAF	1	Measured and Indicated Ore
	0	All waste rock and Inferred Ore
MCAF (pit ref elevation)	1955	Gamagu reference elevation
	1935	Dimbi reference elevation
	1935	Imbruminda reference elevation
	1655	Gremi reference elevation
	1895	Omora reference elevation
<b>Ref elevation applied</b>		
Oxides		Gamagu and Imbruminda taken up to 2,005, then down to 1,800 and up to 2,000m
		Remainder taken from reference up to 2,000m
Waste		Gamagu and Imbruminda taken up to 2,005, then down to 1,800 and up to 2,000m
		Remainder taken from reference up to 2,000m
Mining Cost	USD2.29	Mining cost excluding oxides
	USD3.29	Oxide Mining Cost (including stockpiling and re-handling)
MCAF	USD0.0029	Per meter depth below reference elevation
<b>Payability</b>		
<b>Sulphides</b>		
Cu	96.30%	
Au	95%	
Mo	85%	
<b>Oxides</b>		
Cu	95.34%	
Au	95%	
Mo	85%	
Moisture Content	10%	
<b>Processing Cost (to include Mo)</b>		
Sulphides	USD7.55	
Oxides	USD6.92	
<b>Selling Price</b>		
Cu	USD3.30	/lb
Au	USD1,300	/oz
Mo	USD10	/lb



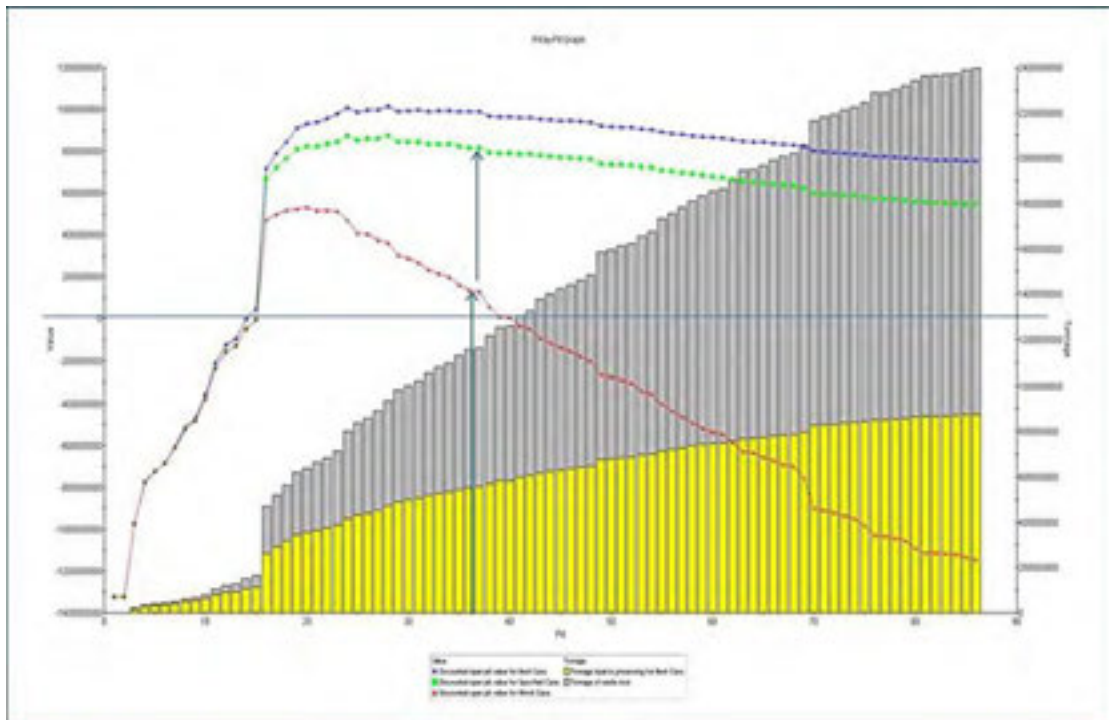
### 15.8.3.2 Pit Shell Selection for Pit Design

Figure 15-15 below depicts the family of nested pits graph generated from the final Whittle analysis for a production rate of 30Mtpa. The value curves were adjusted with the addition of capital expenditure as per the StepWise study, but adjusted downwards to reflect only 75% of the initial StepWise capital as the production rate for the study decreased from 45Mtpa to 30Mtpa.

Pit Shell 36 was the Revenue Factor 1 pit, representing the best value pit prior to the addition of preliminary capital, using the input parameters as depicted in Table 15-28 and resulting in potential reserves of 524Mt. When analysing the graph, the value curves remain flat towards Pit Shell 37, followed by a deflection point beyond which value is reduced more significantly with increased pit size.

Pit Shell 37 was, therefore, selected as the basis for the detailed pit design, as this shell represents the same value as the Revenue Factor 1 pit, but includes an additional 2.4Mt of potential reserves, increasing the potential reserves to 526.8Mt.

Table 15-29 below provides a summary of the Pit Shell 37 tonnages, stripping ratio, oxide ore percentage and relevant elevations.



**Figure 15-15: Yandera PFS Whittle Family of Nested Pits Graph**



**Table 15-29: Pit Shell 37 Summary**

Pit 37 Tonnages	Quantity	Description	
Ore	526,776,735		
Waste	637,155,811		
Total	1,163,932,546	Stripping ratio	1.2
<b>Oxide Ore</b>			
Measured	19,302,727		
Indicated	41,852,813		
Total Oxides	61,155,540		
<b>Sulphide Ore</b>			
Measured	167,261,617		
Indicated	298,359,578		
Total Sulphides	465,621,195	Oxide %	13%
<b>Relevant Elevations</b>			
Pit Bottom	1385	mamsl	
Top of mining	2335	mamsl	
Midpoint	1860	mamsl	
Main connection road elevation	1800	mamsl	

#### 15.8.4 Determination of Pit Shell 37 – Summary

Figure 15-16 illustrates the final waterfall chart to summarize the Whittle process up to the determination of Pit Shell 37.

The detailed pit design process was based on Whittle Pit Shell 37. Potential reserves as depicted in Table 15-29 should never be viewed or communicated as Reserves. This is only potential ore tonnes within a Whittle pit shell. Reserves can only be declared once an acceptable NPV and IRR has been determined based on a practically executable mining production schedule, which in turn is based on a detailed pit design.

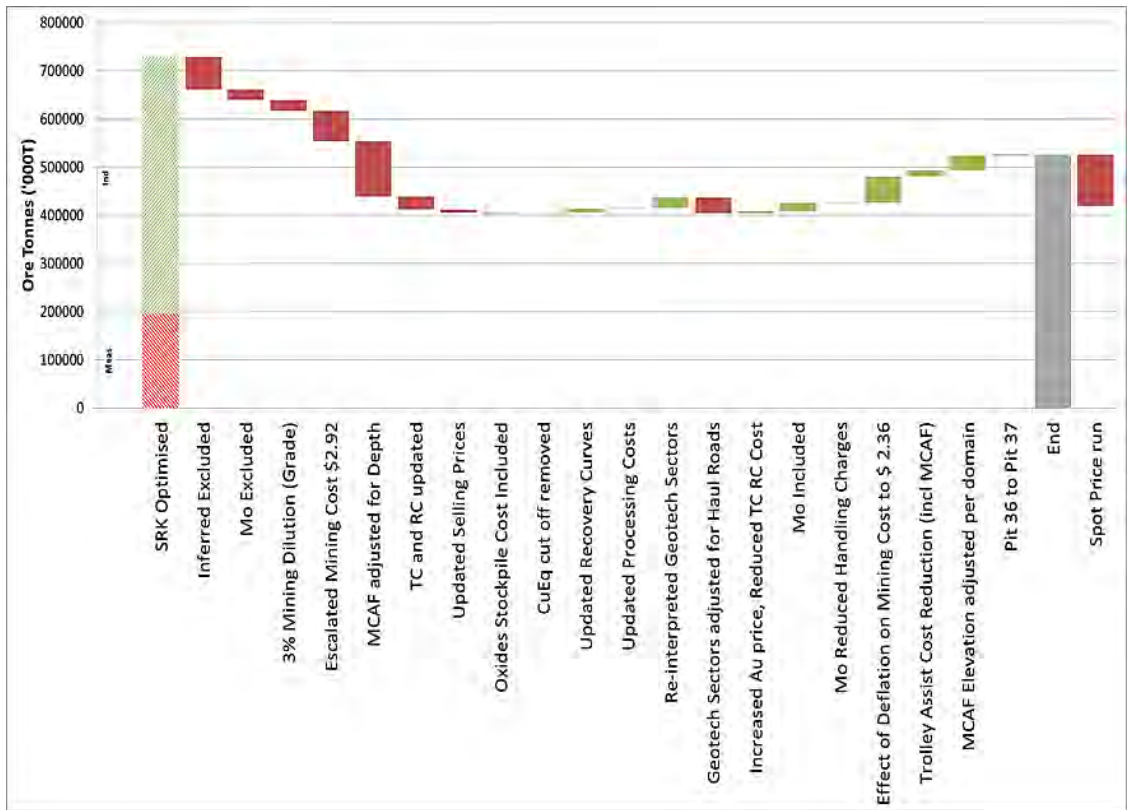


Figure 15-16: Yandera PFS Whittle Family of Nested Pits Graph

## 15.9 Initial Pit Design

Analyses done on the Whittle family of nested pits graphs determined Pit Shell 37 as the one on which to base the initial pit design. Whittle Pit Shell 37 is illustrated in Figure 15-17 below.

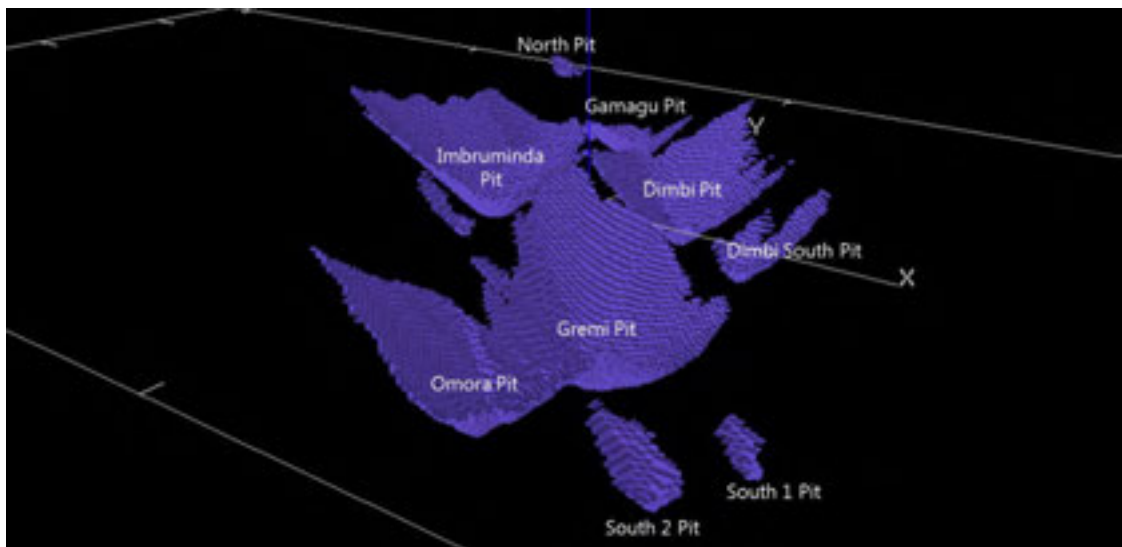


Figure 15-17: Whittle Pit Shell 37





### 15.9.1 Mine Design Criteria

Mine design criteria were applied as depicted in Table 15-30.

**Table 15-30: Mine Design Criteria**

Item	Units	Parameter	Comment
<b>Oxides</b>			
Face Angle	degree	68	
Bench Height	meter	10	
Step Out	meter	6	
Catch Bench	meter	21	At base of oxides
Haul Road Inclination	degree	10	
Haul Road Width	meter	30	Last four benches 15m
<b>Single bench configuration</b>			
<b>Transition and Sulphides</b>			
Face Angle	degree	84	
Bench Height	meter	10	
Step Out	meter	3	
Haul Road Inclination	degree	10	
Haul Road Width	meter	30	
Catch Bench for Sectors 1	meter	12	
Catch Bench for Sectors 2		15	
Catch Bench for Sectors 3		18	
Catch Bench for Sectors 4		21	
Catch bench reduced to 3m alongside Haul Road. Therefore, 30m + 3m Triple Bench configuration.			

Upon completion of the initial design, it was subject to geotechnical analysis and validation as well as optimization.

Once the required design and safety changes had been incorporated, the initial pit design together with the haul route designs were used as main inputs into the preliminary mining production scheduling process, which was necessary to determine the mining fleet size, operating costs, capital costs, Run of Mine (RoM) grade distribution, cash flows and investment potential.

The initial pit design is shown in Figure 15-8.

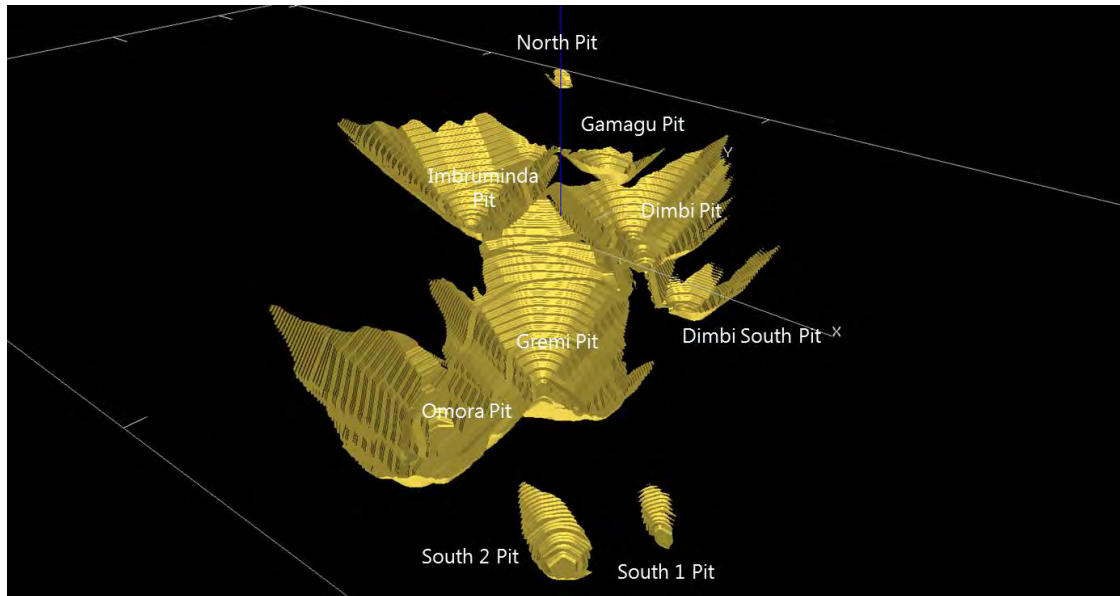
In order to commence mining, access roads to all hilltops had to be designed and scheduled to determine the extent of pre-production earthworks required to enable mining. In addition, these hilltop access roads determined the starting point of production in the various pit areas and the production rates possible from each area. Production rates are driven by the load, haul fleet cycle times, which are largely determined by the length and width of the access, and haul roads.



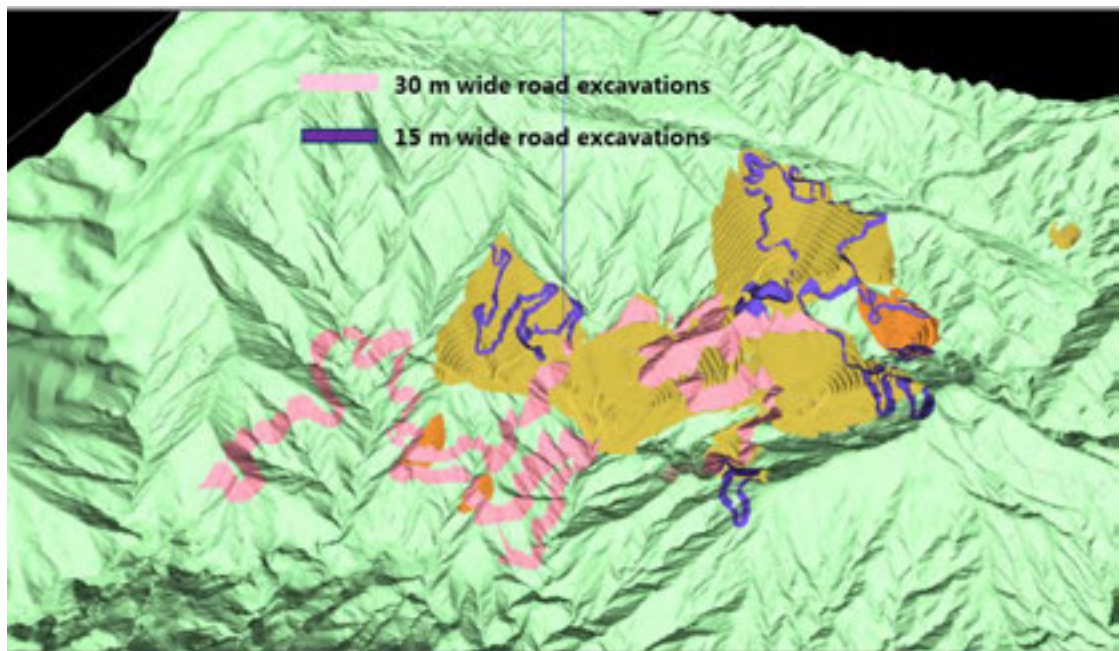


In some areas, the topography did not allow for 30m wide haul roads. Single way haul roads with a 15m width were designed in these areas. As the 15m wide roads only allow one haul truck at a time, ring roads were designed where it was possible to reduce cycle times when mining hilltops.

The earthworks required for the initial hill top access and haul road designs are depicted in Figure 15-9. An additional access road, not shown in the figure, to the North pit was designed and used in the assessment of the economic viability of that pit given the extent of the earthworks required to gain access. It was found not to be economically viable.



**Figure 15-18: Initial Pit Design**



**Figure 15-19: Initial Hill Top Access and Haul Road Design**



## 15.9.2 Initial Pit Design Tonnages

The initial pit design was divided into separate mine planning pit areas to enable an analysis of separate areas for economic viability, given the extent of pre-production earthworks required, and to prioritise the different mining areas in terms of economic ranking in order to maximise NPV during production scheduling. The reconciliation of the Xpac input data to be used in the preliminary production scheduling process and the pit and road designs are summarized Table 15-31.

The subdivisions of Table 15-31 are described below:

### 15.9.2.1 Pits Undepleted

This table contains data pertinent to each of the pits defined for the Project. The resources and potential reserves for the pits were calculated primarily in the Datamine Software. The data was then transferred to the Datamine Rapid Reserver software for design purposes. The final designs for the pits were then compared between the two systems to ensure data integrity and accuracy. The variations in results were found to be more than acceptable for the levels of accuracy required for a PFS.

### 15.9.2.2 Pits Depleted

The Project required the design and scheduling of initial haul roads leading to and crossing through the various pits. Several haul roads intersect the pits, and the tonnages associated with these haul roads were calculated. The table contains the tonnages remaining in the pits after the initial haul roads have been developed and the associated material has been removed from the pits.

### 15.9.2.3 Haul Segments Intersecting Pits

The totals for segments of the initial haul roads intersecting the pits are contained in the table. These results were used to calculate the remaining potential reserves for the pits by removing the tonnage associated with the intersecting segments from the undepleted values in the table.

### 15.9.2.4 Haul Segment Totals

The total volumes and tonnes associated with the development of the entire initial haul network, excluding access to the North pit, are contained in this table. If areas of the deposit were not deemed viable to be mined, the total development tonnes associated with the haul network may be less than reported in this table. It should be noted that these volumes were updated as production scheduling insight and knowledge developed over the course of the mine planning process. Changes were due to optimization and re-design of the initial haul road system to maximise revenue early in the LoM and as such the NPV and IRR of the Project.

### 15.9.2.5 Haul Segments outside Pits

The data contained in the table describes the total material to be developed which does not intersect any of the pits.



**Table 15-31: Initial Pit Design Tonnages**

Table 1 :		PITS UNDEPLETED									
Data Field Name	Units	North	South1HR Original	South2HR Original	Gamagu Original	Dimbi Original Pit	Dimbi Original Pit	Imbruminda	Gremi Orig	Omora Original Pit	TOTAL
Waste Tons - Total	tonnes	705,530	879,176	5,149,949	27,493,162	99,727,280	9,392,698	310,566,075	167,336,104	173,737,323	794,987,297
Total Waste Volume	bcm	278,083	351,668	2,220,203	11,007,115	38,414,767	3,634,765	123,323,429	64,549,242	68,674,730	312,454,001
Ore Tons - Total	tonnes	691,485	602,667	1,563,862	5,891,047	42,376,708	2,642,744	216,222,138	172,694,731	107,767,348	550,452,729
Total Ore Volume	bcm	269,289	234,605	690,982	2,305,120	15,954,567	1,010,700	84,317,336	66,275,698	41,923,112	212,981,409
Total Tons	tonnes	1,397,016	1,481,843	6,713,810	33,384,209	142,103,988	12,035,442	526,788,213	340,030,834	281,504,671	1,345,440,026
Total Volume	bcm	547,372	586,273	2,911,184	13,312,235	54,369,334	4,645,464	207,640,765	130,824,940	110,597,843	525,435,410
Table 2 :		PITS DEPLETED									
Data Field Name	Units	North Depleted	South1 Depleted	South2 Depleted	Gamagu Depleted	Dimbi Depleted	Dimbi South Depleted	Imbruminda Depleted	Gremi Depleted	Omora Depleted Pit (A)	TOTAL
Waste Tons - Total	tonnes	705,530	572,937	4,523,035	26,307,176	95,768,383	7,019,641	304,272,812	151,821,939	170,022,044	761,013,496
Total Waste Volume	bcm	278,083	231,141	1,933,015	10,518,526	36,850,250	2,699,204	120,775,283	58,509,238	67,168,941	298,963,621
Ore Tons - Total	tonnes	691,485	475,275	1,431,011	5,865,393	42,364,311	2,291,618	216,127,096	168,661,159	107,261,980	545,169,328
Total Ore Volume	bcm	269,289	184,872	627,625	2,295,000	15,949,815	872,308	84,277,657	64,761,214	41,702,028	210,939,811
Total Tons	tonnes	1,397,016	1,048,212	5,954,046	32,172,569	138,132,694	9,311,259	520,399,908	320,483,097	277,284,023	1,306,182,824
Total Volume	bcm	547,372	416,014	2,560,640	12,813,526	52,800,065	3,571,513	205,052,940	123,270,453	108,870,968	509,903,492
Table 3:		Haul Segments Intersecting Pits									
Data Field Name	Units	North	South1 HR	South2 HR	Gamagu HR	Dimbi HR	Dimbi South HR	Imbruminda HR	Gremi HR	Omora HR	TOTAL
Waste Tons - Total	tonnes	0	306,239	626,913	1,185,986	3,958,898	2,373,057	6,293,263	15,514,165	3,715,280	33,973,801
Total Waste Volume	bcm	0	120,527	287,188	488,589	1,564,517	935,560	2,548,146	6,040,004	1,505,790	13,490,320
Ore Tons - Total	tonnes	0	127,391	132,851	25,654	12,396	351,126	95,042	4,033,572	505,368	5,283,401
Total Ore Volume	bcm	0	49,733	63,356	10,120	4,751	138,391	39,679	1,514,484	221,085	2,041,598
Total Tons	tonnes	0	433,630	759,764	1,211,640	3,971,294	2,724,183	6,388,305	19,547,737	4,220,648	39,257,201
Total Volume	bcm	0	170,259	350,544	498,709	1,569,268	1,073,951	2,587,825	7,554,487	1,726,874	15,531,919
Table 4 :		Haul Segments Total									
Data Field Name	Units	North	South1 Segment	South2 Segment	Gamagu Segment	Dimbi Segment	Dimbi South Segment	Imbruminda Segment	Gremi Segment	Omora Segment	TOTAL
Waste Tons - Total	tonnes		10,218,908	16,491,447	1,310,453	5,689,494	2,668,731	9,039,782	15,569,631	3,939,211	64,927,657
Total Waste Volume	bcm		4,037,552	6,560,381	539,534	2,243,594	1,065,992	3,642,480	6,061,372	1,594,582	25,745,488
Ore Tons - Total	tonnes		183,420	589,955	25,785	20,848	383,750	95,523	4,089,202	505,368	5,893,851
Total Ore Volume	bcm		71,534	252,417	10,171	8,062	151,820	39,903	1,538,235	221,084	2,293,226
Total Tons	tonnes		10,402,328	17,081,402	1,336,238	5,710,342	3,052,481	9,135,305	19,658,833	4,444,579	70,821,508
Total Volume	bcm		4,109,086	6,812,798	549,704	2,251,657	1,217,812	3,682,384	7,599,607	1,815,666	28,038,714
Table 5 :		Haul Segments Outside Pits									
Data Field Name	Units	North	South1 Segment	South2 Segment	Gamagu Segment	Dimbi Segment	Dimbi South Segment	Imbruminda Segment	Gremi Segment	Omora Segment	TOTAL
Waste Tons - Total	tonnes	0	9,912,669	15,864,534	124,467	1,730,596	295,674	2,746,519	55,466	223,932	30,953,857
Total Waste Volume	bcm	0	3,917,025	6,273,193	50,945	679,077	130,432	1,094,334	21,369	88,792	12,255,168
Ore Tons - Total	tonnes	0	56,029	457,104	131	8,452	32,624	481	55,630	0	610,450
Total Ore Volume	bcm	0	21,801	189,061	51	3,311	13,429	224	23,751	0	251,628
Total Tons	tonnes	0	9,968,697	16,321,638	124,598	1,739,048	328,298	2,747,000	111,096	223,931	31,564,307
Total Volume	bcm	0	3,938,827	6,462,254	50,995	682,389	143,861	1,094,558	45,120	88,792	12,506,795



## 15.10 Pit Design Optimization Process

The surface connection roads towards the three potential satellite pits, temporarily named as North, South 1 and South 2, and from the main pit area to the crushing and milling precinct and towards the waste rock dump and oxide ore stockpile area, as well as the hill top access roads to enable mining in the various pit areas were completed and scheduled using the XPac software.

Given its remote location, the North pit, also referred to as the Frog satellite pit, was assessed economically for viability. The increased hauling distance towards the mining precinct and the waste rock dump, as well as a relatively high stripping ratio when compared to the other pits in the main mining area, resulted in a relatively high operating cost. The high production cost was only overcome marginally by the metal content of the pit. Most of the ore in the North pit consisted of oxide material for which recoveries are significantly lower than for sulphide ore. The recoveries as used in the Whittle optimization process were applied in the economic analysis.

The addition of capital costs required for the haul road to link the North pit to the rest of the operation renders the North pit economically non-viable and as such, this pit and its access road did not form part of the further analysis to determine economically viable reserves from the geological resources. The North pit contributed approximately 0.1% to the total tonnage of the potential reserves. Its omission will, therefore, have an insignificant impact on results.

A similar result was obtained when the Dimbi South pit was assessed. Dimbi South contained 0.4% of the potential reserve tonnage.

The Gamagu pit that contains 1% of the total potential reserve and has the highest stripping ratio of all the pits came out as marginally positive in the economic assessment and, as such, was scheduled for production at the end of the LoM.

The production scheduling process indicated that a double benching deployment strategy allowed for temporary ramps throughout the life of the Omora pit, thus enabling the removal of a portion of the final haul road from the initial pit design. The scheduling also indicated that access and haul road design changes were required to access priority areas earlier in the LoM in order to maximise NPV.

Final slope angle optimization and the design changes to exclude the Dimbi South pit and to include the connections between the pit design and final external haul roads were made before the pit design was finalized.

The final pit design together with haul route designs were used as main inputs into the mining production scheduling process, which was re-run on the original geological domains instead of the mine planning prioritization areas in order to reflect correctly the processing recoveries based on geological and not mine planning delineation.

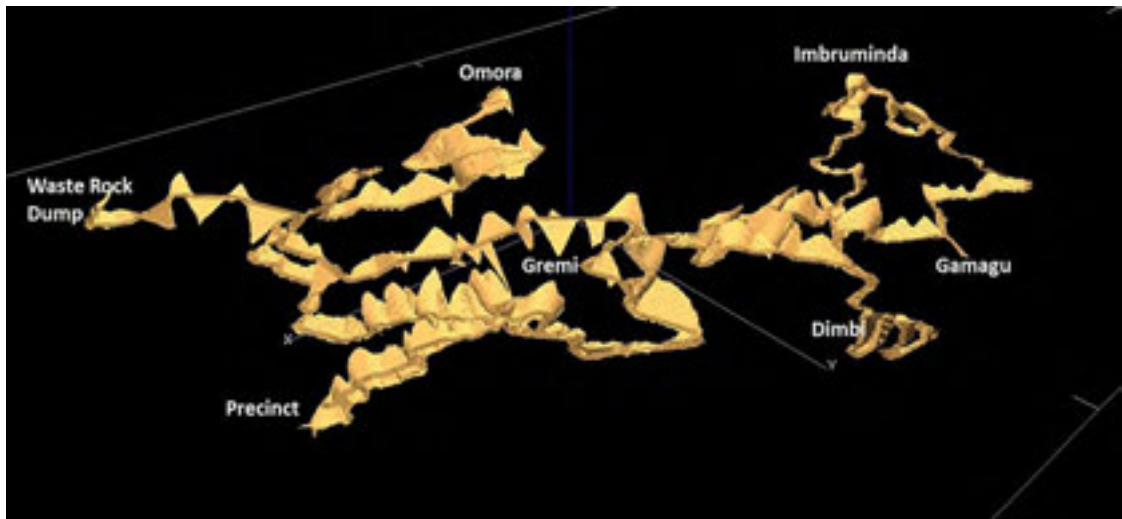
## 15.11 Final Pit Design

Design and safety changes were incorporated to develop the final pit design together with the hill top access and haul road designs. These were used as the main inputs into the mining production scheduling process, which, in turn, formed the basis of the finalization of the mining fleet size, operating costs, capital costs, RoM grade distribution, cash flows and investment potential.





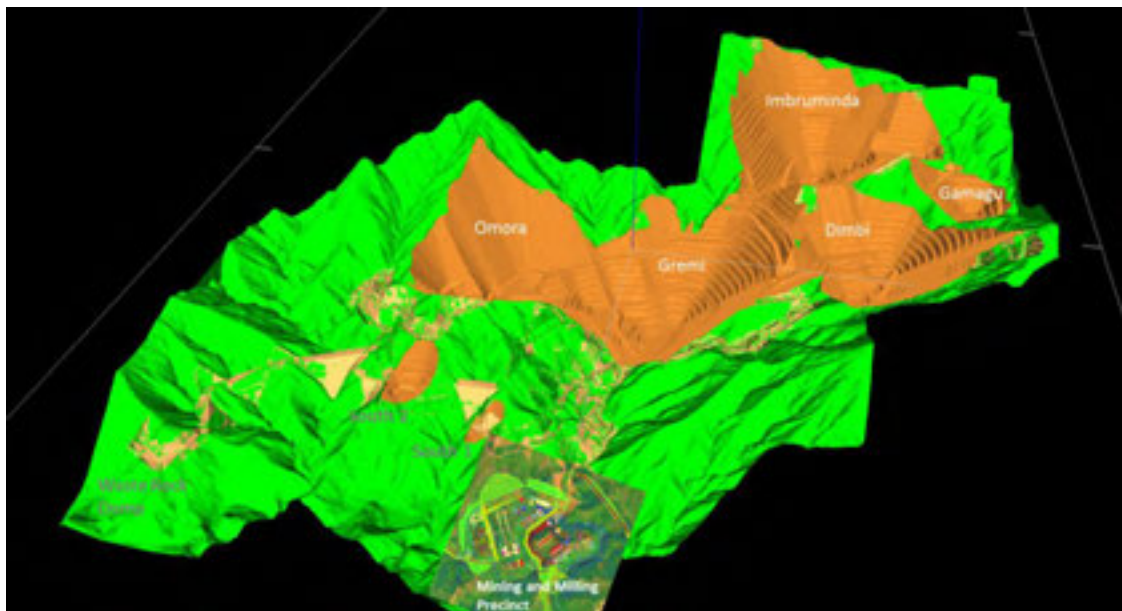
Figure 15-20 depicts the extent of the haul road and hill top access development required to enable the timely commencement of the mining schedule.



**Figure 15-20: Hill Top Access and Haul Road Development**

The total volume of earthworks required to establish the 15m hill top accesses and the 30m haul roads depicted above amounts to 32 million m<sup>3</sup> consisting of 26 million m<sup>3</sup> of cut material and 6 million m<sup>3</sup> of fill material. The detailed breakdown of this pre-production work is shown in Table 16-8 in Section 16.3.1, where the initial haul road construction is described.

Figure 15-21 depicts the final pit design within the topography after mining, but without showing the impact of waste backfilling into Gremi. The extent of backfilling is depicted in Figure 16-28 in Section 16.3.3 where 3D pit deployment strategy is described.



**Figure 15-21: Final Pit Design within Topography**



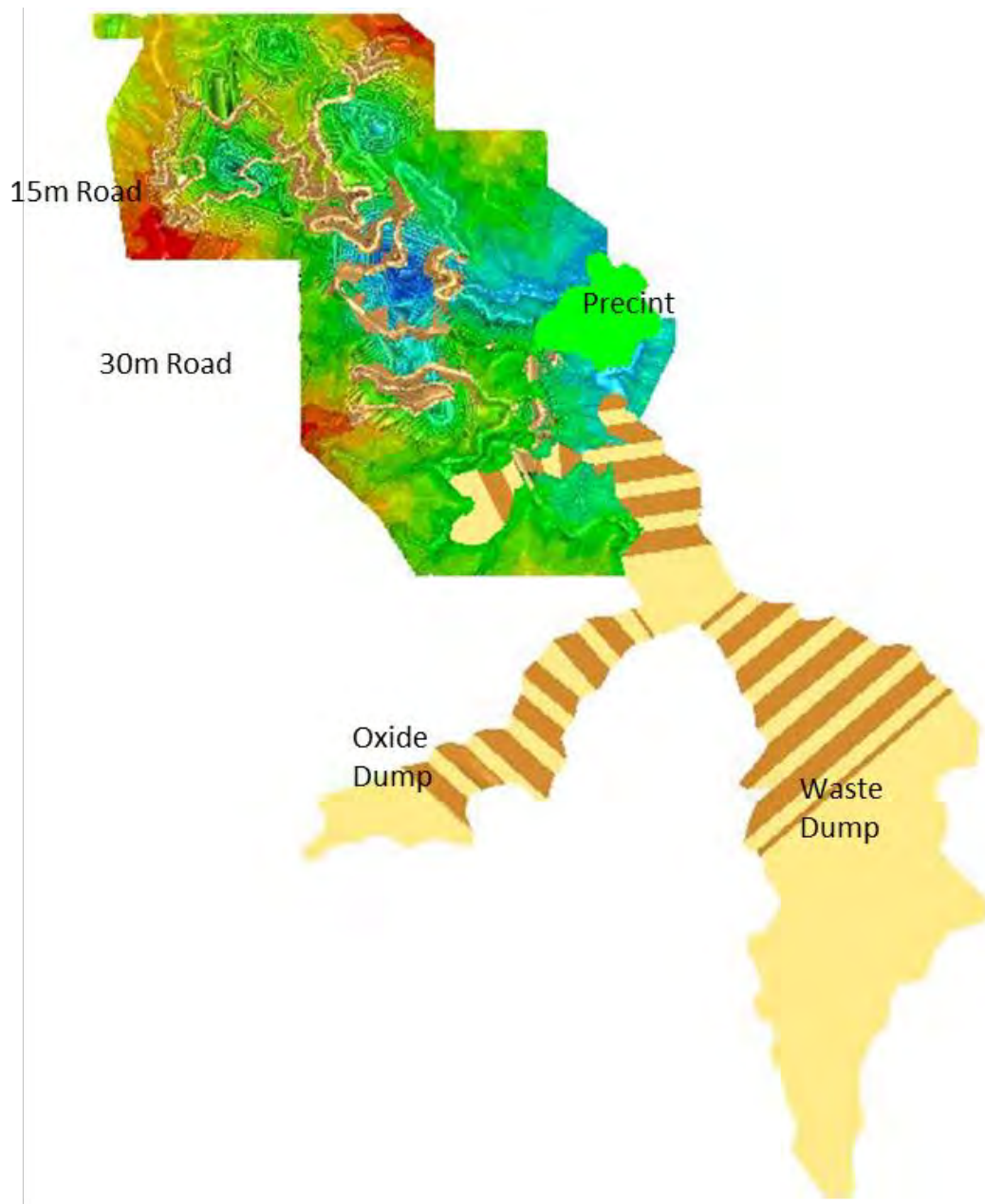
The mountainous topography necessitates the creation of suitable flat areas required for the mining operation. Therefore, areas external to the main pit will be used as follows:

- The mined out area of the South 1 pit will be used as primary crusher location from where a high angle conveyor will transport the crushed ore to the milling precinct.
- The mined out area of the South 2 pit will be used as an operational stockpile to place ore when the processing plant cannot accommodate the mined ore.
- The same area will be used as a short-term operational stockpile for sulphide material while batch processing oxide ore, and vice versa. The stockpiling capacity of this area is limited to  $\pm 2$ Mt. The South 2 pit stockpile will be mainly contained within the pit excavation, which should limit environmental impacts.
- Ore from these two pits, totalling 1.9Mt, will be temporarily stored on the waste rock dump location until the crushing and milling plant becomes operational.
- The surplus oxide ore, and the below cut-off sulphide ore will be stockpiled on separate areas allocated within the oxide stockpile area in the WRD; as both ore types will continuously be consumed during the LoM.
- The Mogoru Creek will be used as the oxide stockpile. The Yewago valley will mainly consist of the below cut-off sulphide ore stockpile.
- The oxide stockpile volumes are dependent on the final metallurgical test results, which will determine the ore treatment philosophy and could have an impact on the final WRD volumes.

For mine planning purposes, the pit design was subdivided into separate pit areas to prioritise the different mining areas in terms of economic ranking in order to maximise NPV during production scheduling.

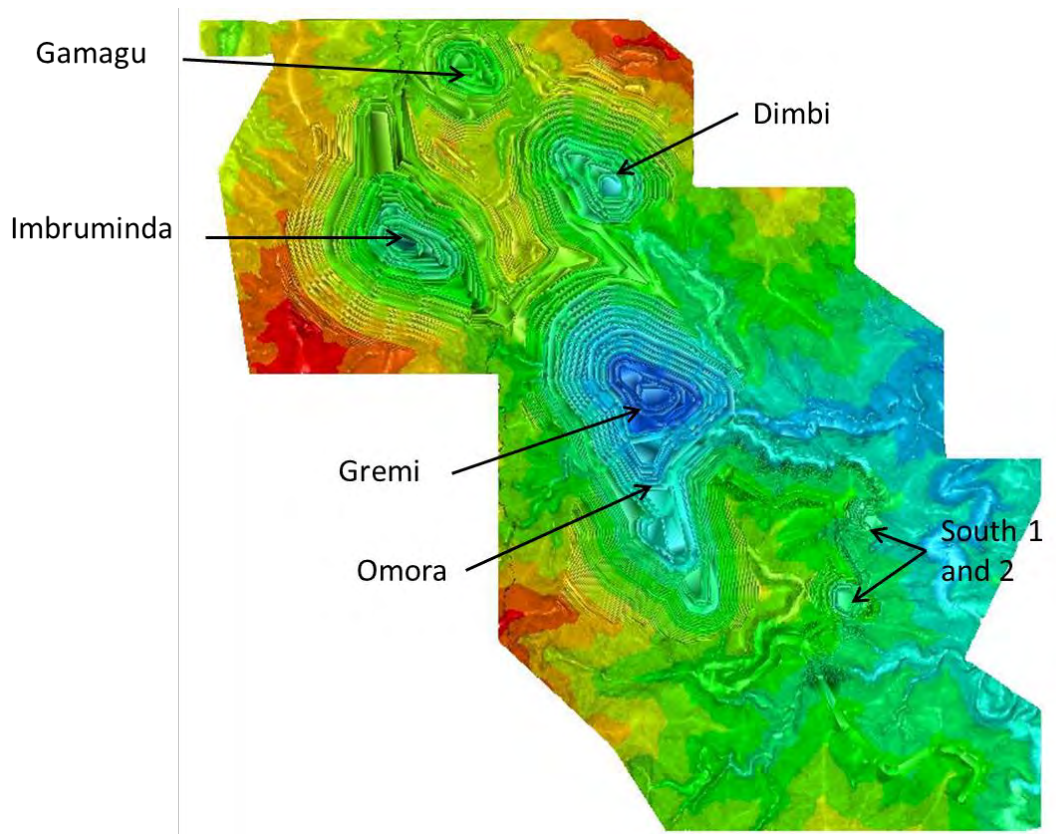


Figure 15-22 to Figure 15-34 provide more detail on the pit locations, designs, phases and cross sections.

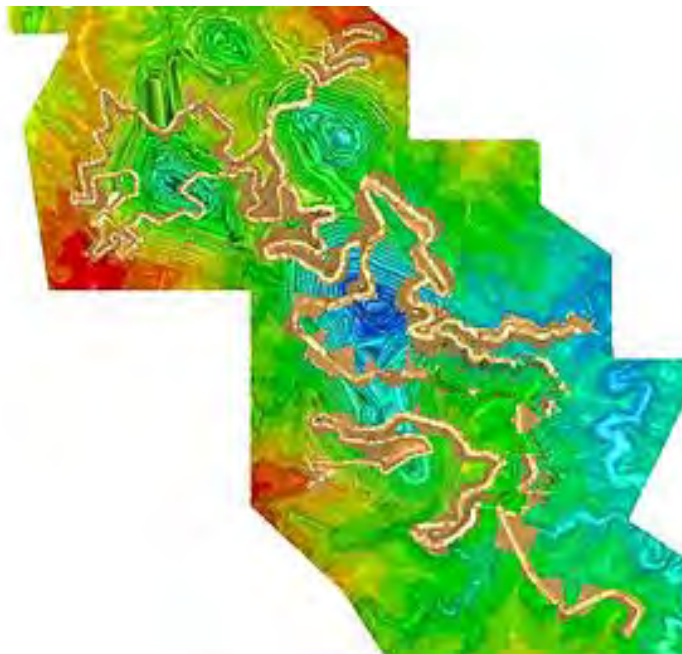


**Figure 15-22: Pit Design Locality**

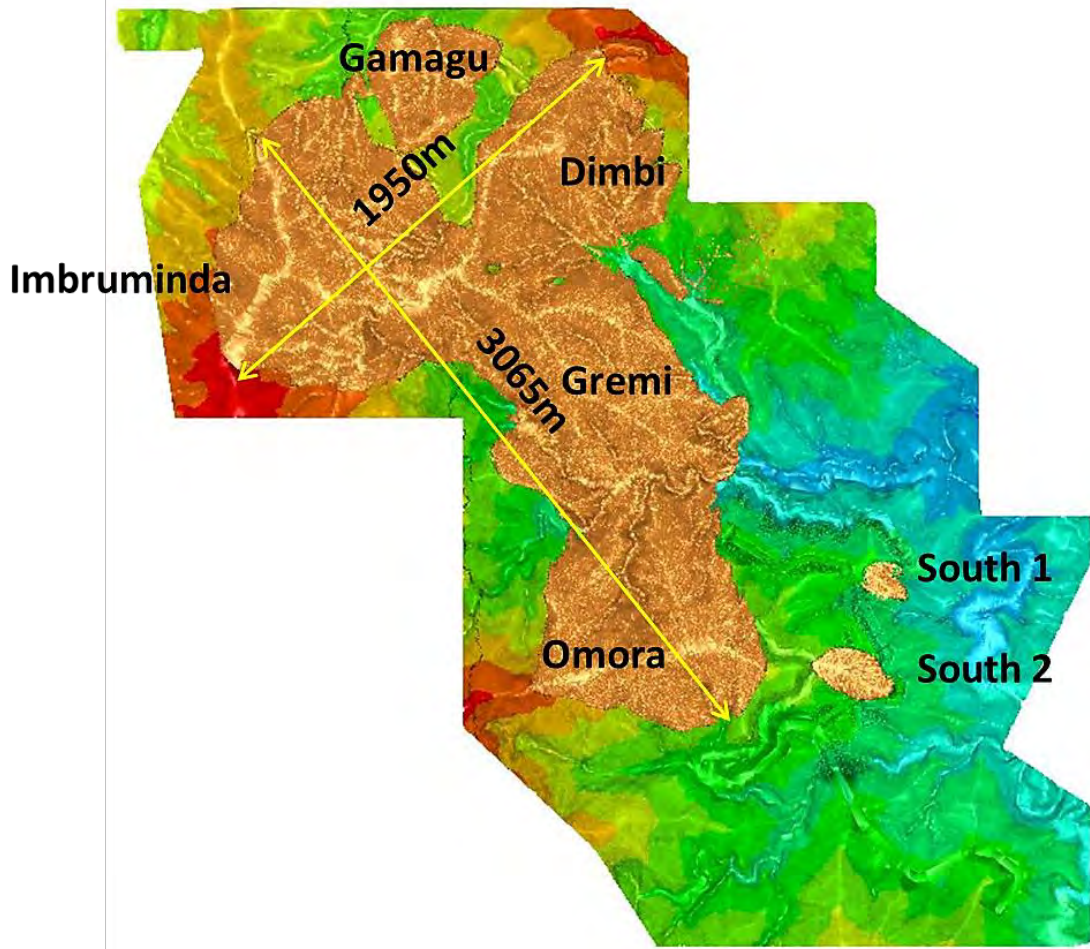




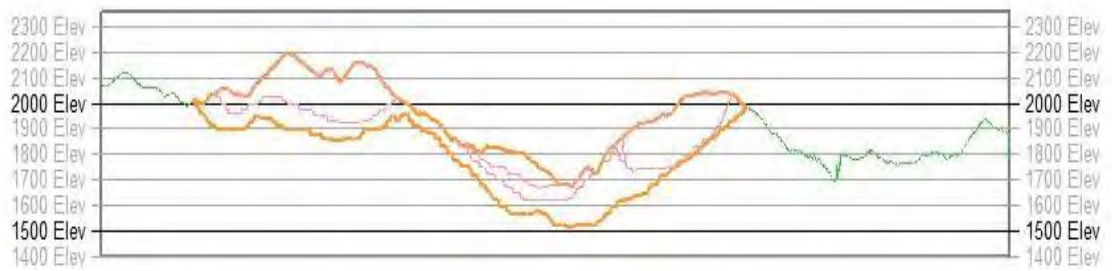
**Figure 15-23: Location of Pits**



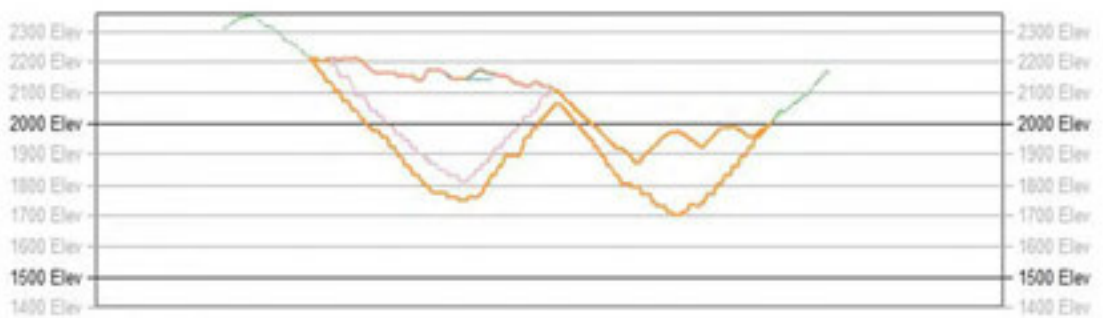
**Figure 15-24: Hill top Access and Haul Roads**



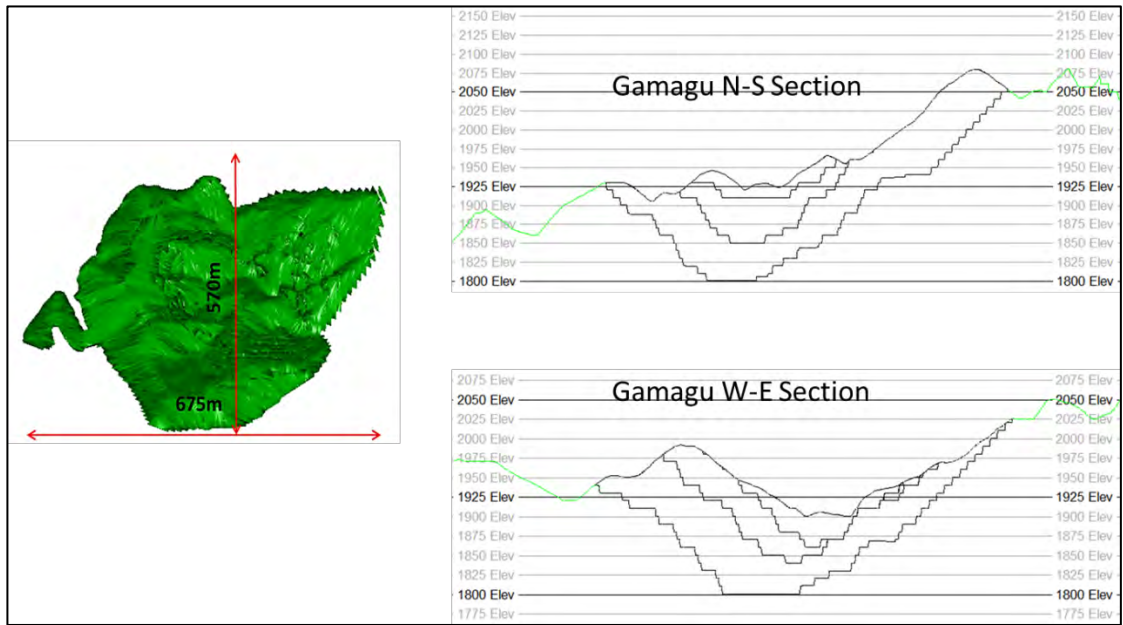
**Figure 15-25: Layout of the Pits**



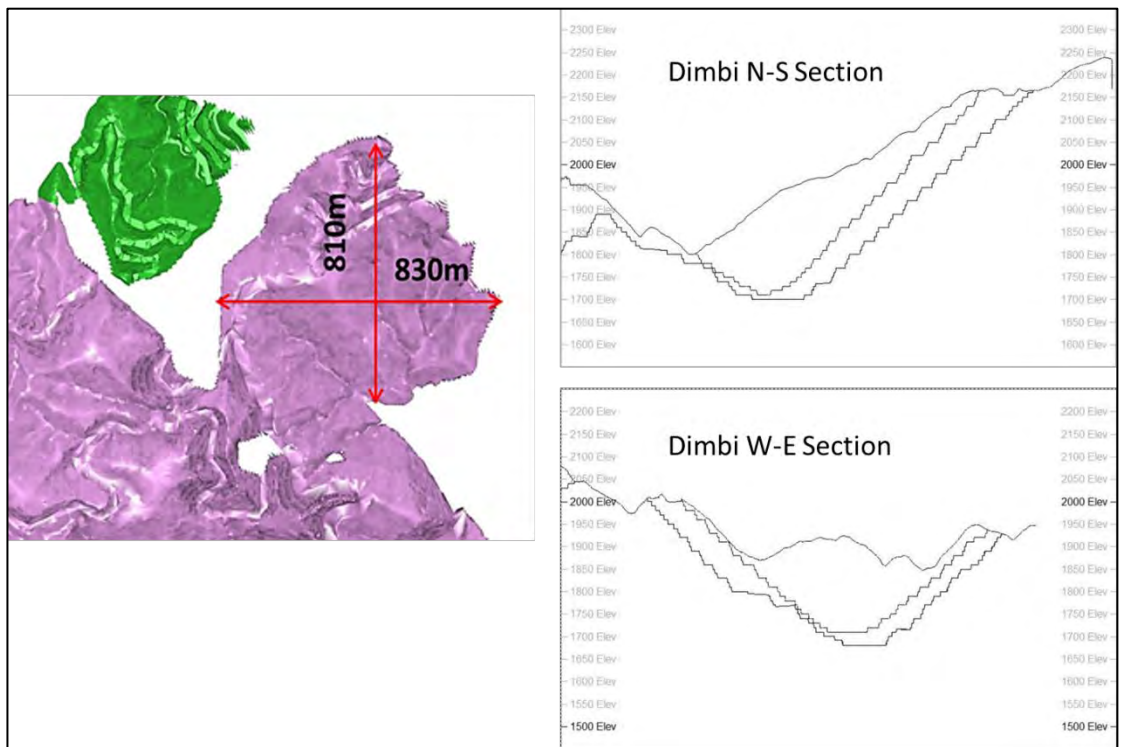
**Figure 15-26: Total Pit N-S Section (A-A)**



**Figure 15-27: Total Pit W-E Section (B-B)**

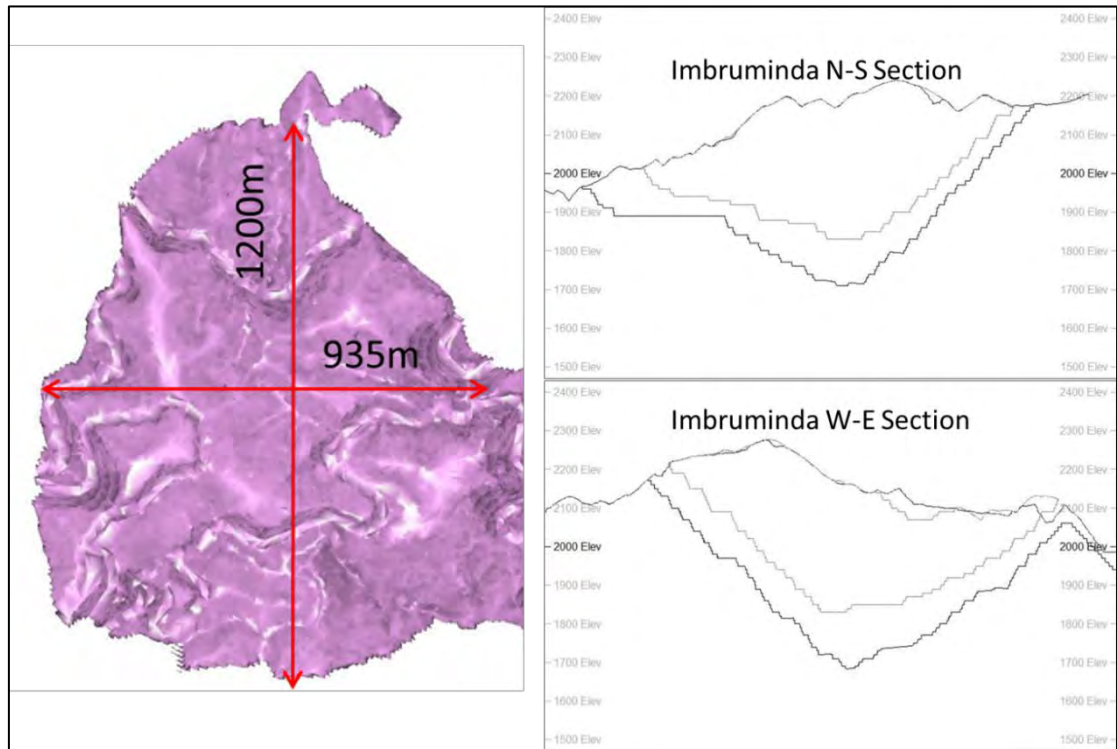


**Figure 15-28: Gamagu Pit Dimensions**

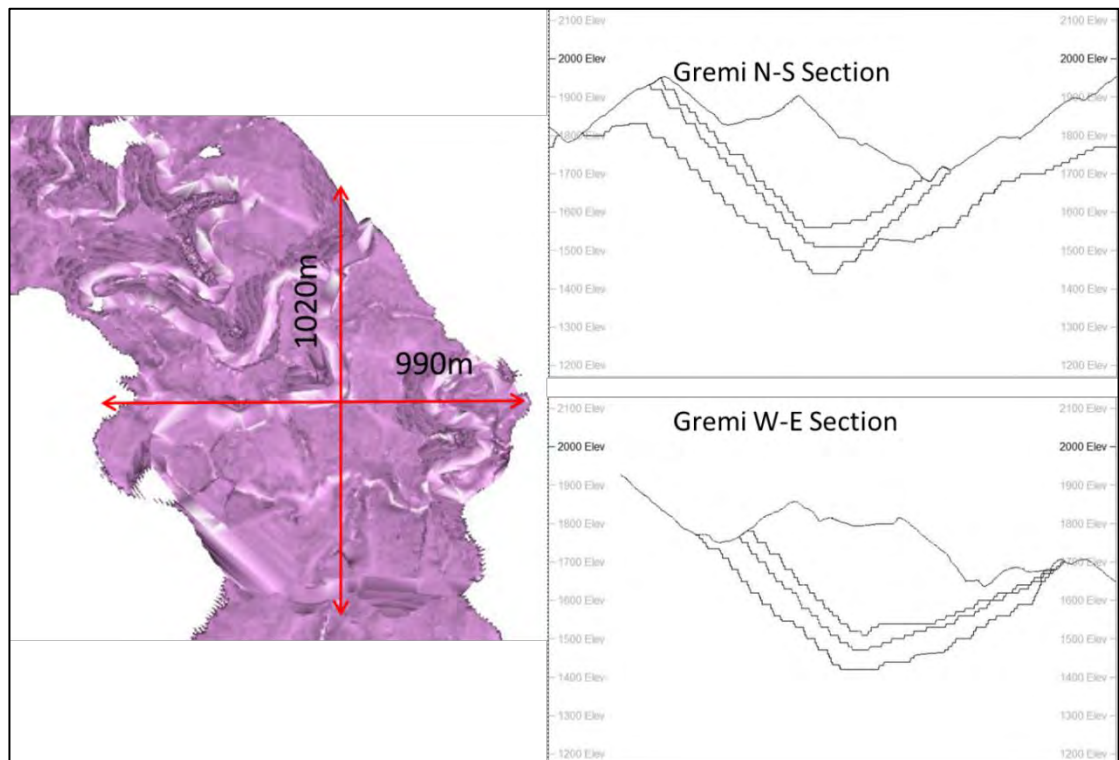


**Figure 15-29: Dimbi Pit Dimensions**

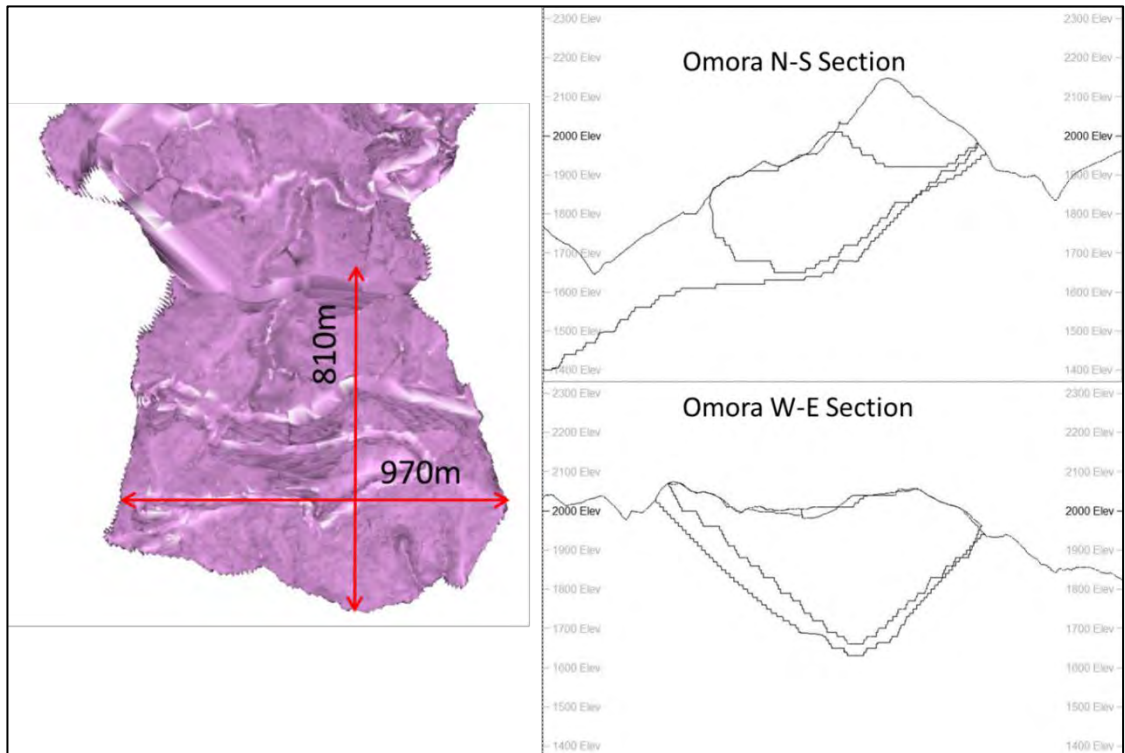




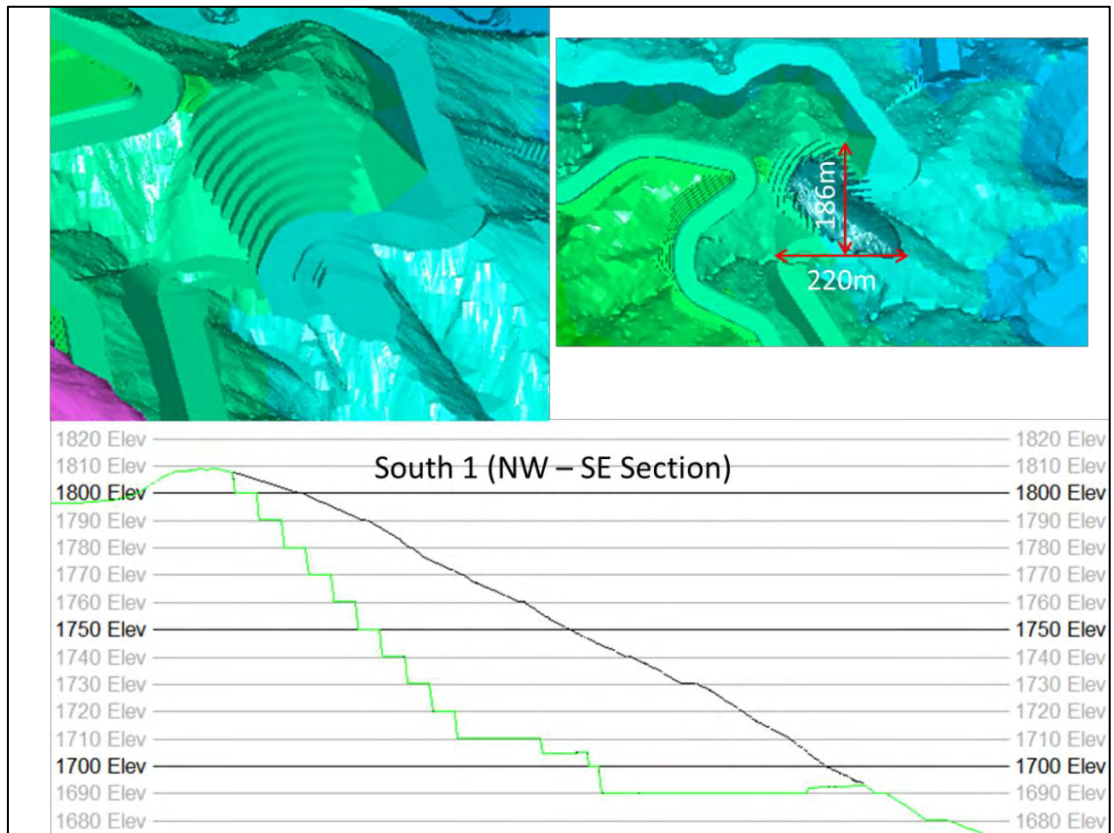
**Figure 15-30: Imbruminda Pit Dimensions**



**Figure 15-31: Gremi Pit Dimensions**



**Figure 15-32: Omora Pit Dimensions**



**Figure 15-33: South 1 Pit Design – Location for Crusher Pad**

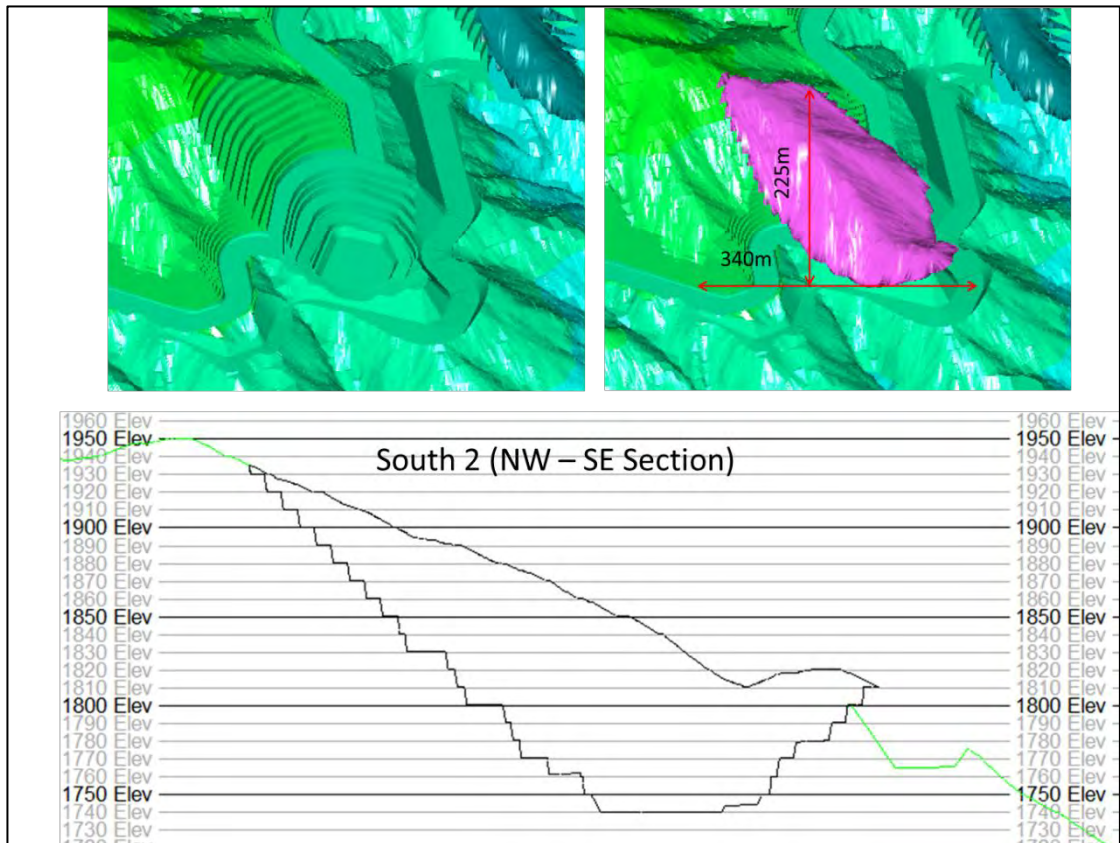


Figure 15-34: South 2 Pit Design – Operational Stockpile Area

## 15.12 Production Scheduling

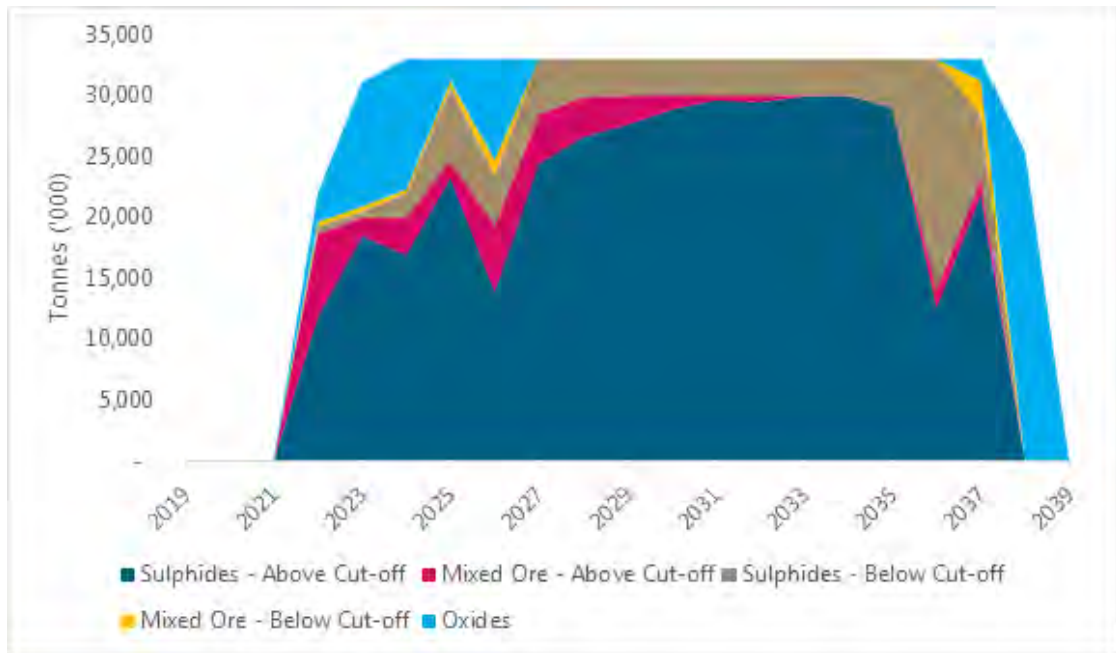
The production rates from the various pits were completed based on achieving an annual production rate of 30Mt of above cut-off grade sulphide ore. The cut-off grade that resulted in the most beneficial financial results was 0.22% Cu CoG.

The focus areas for ramp up and the initial years of the LoM was driven by the pit ranking results to maximise upfront value in terms of higher grades with the lowest possible waste mining in these years, but still aiming to achieve steady state ore supply as soon as possible in order to maximise revenue upfront, and thus also NPV and IRR.

Below cut-off, grade sulphide ore was stockpiled to be used to make up the additional ore supply to a level of 33Mtpa. In years where the total sulphide ore supply was insufficient, oxide ore was used to make up the deficit to 33Mtpa. In the initial years of the LoM, oxide is used as mined and later in the LoM from the oxide ore stockpile.

Figure 15-35 illustrates the RoM material fed to the processing plant over the LoM. Details on the production scheduling completed for the LoM are provided.





**Figure 15-35: Plant Feed over the Life of Mine**

The production schedule had to conform to both safety and practicality of execution requirements. An operational slope angle with a maximum of double benching was applied. An operational slope angle any steeper than this would be unsafe given the high rainfall and seismic activity at the project site.

To demonstrate practicality of execution, the mining production schedule was completed on a blast block by blast block basis, creating and maintaining mining benches, while ensuring that there was sufficient space to allow for inter-bench temporary ramps at a maximum gradient of 1:10 and that each block had access to a haul road network towards the ore and waste destinations at all times.

### 15.13 Equipment Selection

An equipment selection and size matching exercise was completed to determine the mining equipment suitable to meet production targets of the mine. In-situ rock will be fragmented using drill and blast techniques. The fragmented material will then be loaded using electric rope shovels onto diesel/electric dump trucks, which will haul the material to the crusher pad, ore stockpiles or waste rock dump. The types, size and number of mining equipment recommended for the Project are provided.

### 15.14 Opex and Capex

The project working costs were determined from first principles using an activity-based cost model. The activity-based costing model uses the mine and process design criteria and production schedule inputs to derive cost rates for mining, processing and engineering activities. The derived rates are used in the model, which is driven by the production schedule to obtain the overall operating cost. Details on the operating costs of the Project are provided in Section 21.8 and are summarized Table 15-32.

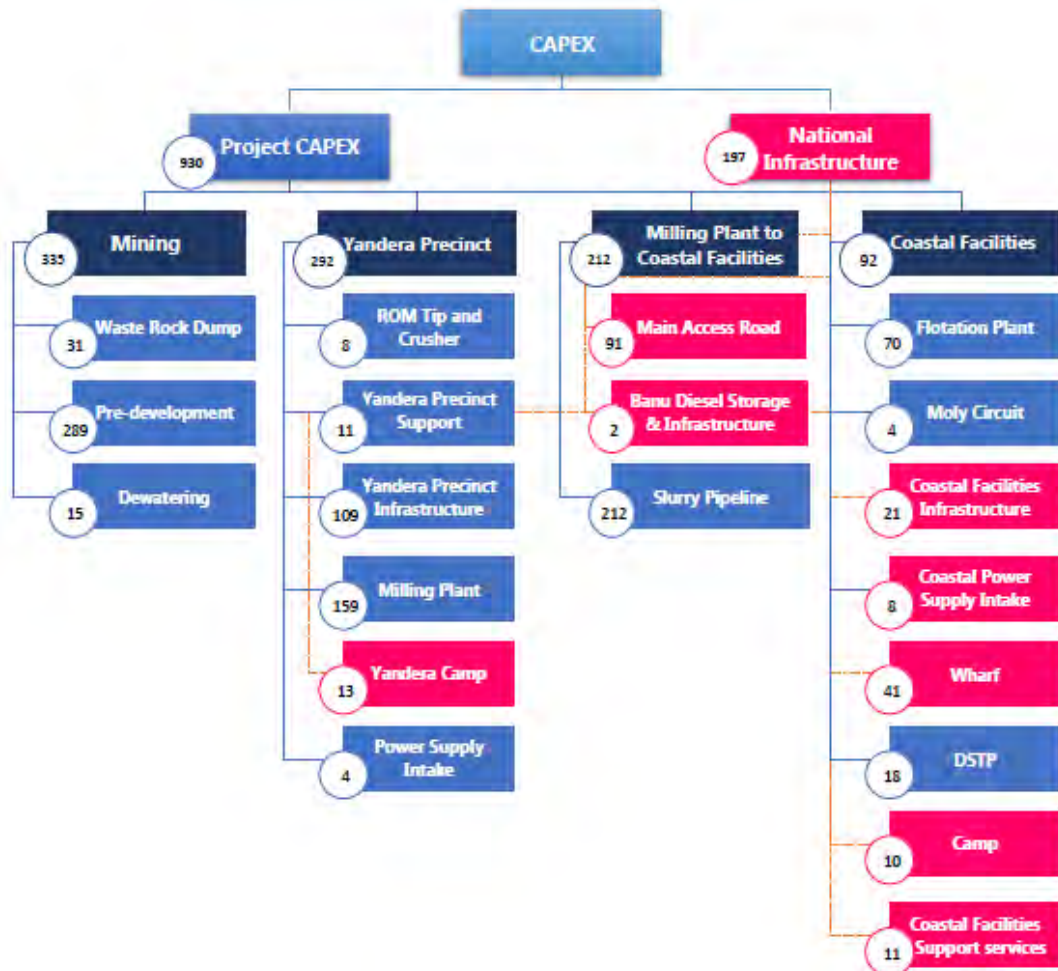




**Table 15-32: Breakdown of Operating Costs**

Cost Item	Unit	Cost
Mining	USD/milled tonne	5.87
Yandera Precinct	USD/milled tonne	0.24
Milling Plant	USD/milled tonne	4.42
Mill to Coastal Facilities	USD/milled tonne	0.24
Coastal Facilities	USD/milled tonne	1.24
General and Administration	USD/milled tonne	0.91
<b>Total Opex</b>	<b>USD/milled tonne</b>	<b>12.92</b>

The Capex estimate for the Project was prepared as a flat base using MS Excel 2016. Deterministic estimating techniques were applied to determine direct costs and the fourth quarter of 2017 was used as the base date. The overall capital cost estimate of the Project is USD1.128 billion and is summarized in Figure 15-36 below.



**Figure 15-36: Total Capital Cost Estimate of the Yandera Project (USDmil)**



## 15.15 Financial Model

A discounted cash flow model was used to complete a financial evaluation of the Project using inputs including the production schedule, revenue schedule, operating cost schedule, taxes and royalties in accordance with current PNG tax legislation and the capital cost estimate and schedule. The results of the financial evaluation are discussed in Section 22 and are summarized in Table 15-33. The values depicted here assume that NI required for the successful execution of this Project will be funded and put in place timeously by the PNG government. NI amounts to USD197million in real terms.

**Table 15-33: Financial Analysis**

Cost Item	Unit	Cost
NPV – Real	USD	1,038 million
IRR – Real	%	23.5
Project Capital (excluding national infrastructure) - Real	USD	930 million
Payback Period – Real	years	5 years, 8 months
Life of Mine	years	20

## 15.16 Mineral Reserve Estimation

This section defines the Minerals Reserves Estimate for the Project. Relevant economic parameters were applied to determine the portions of the Resource that can be extracted economically in accordance with the requirements of the NI 43-101 Standards.

According to the CIM definition standards, Mineral Reserves are defined as follows:

- Mineral Reserves are those parts of Mineral Resources which, after the application of all mining factors, result in an estimated tonnage and grade which, in the opinion of the Qualified Person(s) making the estimates, is the basis of an economically viable project after taking account of all relevant processing, metallurgical, economic, marketing, legal, environment, socio-economic and government factors. Mineral Reserves are inclusive of diluting material that will be mined in conjunction with the Mineral Reserves and delivered to the treatment plant or equivalent facility. The term "Mineral Reserve" need not necessarily signify that extraction facilities are in place or operative or that all governmental approvals have been received. It does signify that there are reasonable expectations of such approvals.*

The total Mineral Reserves Estimate as at 27 November 2017, based on geological domains, is summarized in Table 15-34.

**Table 15-34: Total Probable Mineral Reserves Estimate**

Material	Probable Reserve Ore (kt)	Cu Grade (%)	Mo Grade (%)	Au Grade (ppm)	Pit Estimates (kt)
Oxide Ore	60,482	0.3365	0.0057	0.0819	
Sulphide Ore	441,040	0.3325	0.0107	0.0683	
Transitional Ore	38,975	0.3625	0.0107	0.0885	
<b>Total Ore</b>	<b>540,497</b>	<b>0.3351</b>	<b>0.0102</b>	<b>0.0713</b>	



Material	Probable Reserve Ore (kt)	Cu Grade (%)	Mo Grade (%)	Au Grade (ppm)	Pit Estimates (kt)
<b>Total Waste</b>					<b>733,772</b>
<b>Total</b>					<b>1,274,269</b>
<b>Stripping Ratio (W:O)</b>					<b>1.36</b>

The Mineral Reserves for the initial hilltop access and haul roads within the pits and the pit areas excluding access and haul roads are illustrated in Table 15-35 and Table 15-36 respectively.

**Table 15-35: Hill Top Access and Haul Road In-Pit Probable Reserves per Geological Domain**

Item	Units	North Domain	Dimbi Domain	Imbruminda Domain	Gremi Domain	Omora Domain	Total - All Domains
Oxide Ore Tonnes	t	148,073	117,376	167,990	3,712,276	591,183	4,736,898
Cu Equivalent Grade	%	0.0195	0.0549	0.2777	0.4668	0.4733	0.4368
Cu Grade	%	0.0000	0.0545	0.2474	0.4231	0.4691	0.4003
Mo Grade	%	0.0094	0.0006	0.0025	0.0057	0.0053	0.0055
Au Grade	g/t	0.0499	0.0008	0.0690	0.0994	0.0094	0.0831
Sulphide Ore Tonnes	t	206,246	285,108	418,786	635,532	542,388	2,088,059
Cu Equivalent Grade	%	0.2561	0.3552	0.1840	0.2509	0.1778	0.2332
Cu Grade	%	0.2162	0.3166	0.1476	0.2142	0.1626	0.2016
Mo Grade	%	0.0056	0.0060	0.0057	0.0078	0.0003	0.0050
Au Grade	g/t	0.0550	0.0491	0.0462	0.0335	0.0323	0.0400
Transitional Ore Tonnes	t	17,036	0	131,043	338,988	0	487,066
Cu Equivalent Grade	%	0.0339	0	0.1658	0.4004	0	0.3245
Cu Grade	%	0.0138	0	0.1380	0.3412	0	0.2751
Mo Grade	%	0.0071	0	0.0021	0.0086	0	0.0068
Au Grade	g/t	0.0000	0	0.0497	0.0798	0	0.0689
Waste Tons - Total	t	278,949	9,077,211	6,105,792	9,412,461	3,610,929	28,485,342
Total Waste Volume	Bcm	115,520	3,631,023	2,527,700	3,705,611	1,594,463	11,574,317
Rd	t/m3	2.41	2.50	2.42	2.54	2.26	2.46
Ore Tons - Total	t	371,354	402,483	717,819	4,686,795	1,133,571	7,312,022
Cu Equivalent Grade	%	0.1516	0.2676	0.2026	0.4328	0.3319	0.3712
Cu Grade	%	0.1207	0.2402	0.1692	0.3889	0.3225	0.3352
Mo Grade	%	0.0072	0.0045	0.0043	0.0062	0.0029	0.0055
Au Grade	g/t	0.0504	0.0350	0.0522	0.0890	0.0203	0.0698
Total tonnes	t	650,303	9,479,695	6,823,611	14,099,256	4,744,500	35,797,365
Strip Ratio		0.75	22.55	8.51	2.01	3.19	3.90



**Table 15-36: Production Probable Reserves Estimate per Geological Domain**

	Units	North Domain	Dimbi Domain	Imbruminda Domain	Gremi Domain	Omora Domain	Total - All Domains
<b>Oxide Ore Tonnes</b>	tonnes	3,434,869	5,162,509	19,266,554	9,695,043	18,186,399	55,745,374
Cu Equivalent Grade	%	0.2807	0.3050	0.3350	0.4067	0.4137	0.3670
Cu Grade	%	0.2349	0.2751	0.2880	0.3684	0.3907	0.3310
Mo Grade	%	0.0037	0.0081	0.0037	0.0085	0.0062	0.0057
Au Grade	g/t	0.1042	0.0680	0.1068	0.0870	0.0521	0.0818
<b>Sulphide Ore Tonnes</b>	tonnes	11,634,420	39,397,736	160,568,372	134,956,400	92,395,150	438,952,079
Cu Equivalent Grade	%	0.3440	0.4037	0.3906	0.4005	0.3908	0.3936
Cu Grade	%	0.2730	0.3537	0.3283	0.3381	0.3332	0.3332
Mo Grade	%	0.0083	0.0082	0.0085	0.0123	0.0139	0.0108
Au Grade	g/t	0.1083	0.0610	0.0872	0.0632	0.0417	0.0685
<b>Transitional Ore Tonnes</b>	tonnes	1,992,283	3,702,059	13,481,253	10,591,115	8,721,268	38,487,978
Cu Equivalent Grade	%	0.3462	0.3272	0.3998	0.4594	0.5175	0.4331
Cu Grade	%	0.2630	0.2786	0.3280	0.3828	0.4547	0.3636
Mo Grade	%	0.0094	0.0072	0.0076	0.0137	0.0140	0.0108
Au Grade	g/t	0.1288	0.0638	0.1146	0.0862	0.0531	0.0887
<b>Ore Tons- Total</b>	tonnes	17,061,573	48,262,304	193,316,179	155,242,557	119,302,817	533,185,430
Cu Equivalent Grade	%	0.3315	0.3873	0.3857	0.4049	0.4036	0.3937
Cu Grade	%	0.2642	0.3395	0.3243	0.3430	0.3509	0.3351
Mo Grade	%	0.0075	0.0081	0.0080	0.0121	0.0127	0.0102
Au Grade	g/t	0.1098	0.0619	0.0911	0.0663	0.0442	0.0713
<b>Waste Tons- Total</b>	tonnes	30,523,142	146,717,386	238,520,135	119,127,541	170,398,153	705,286,358
Cu Equivalent Grade	%	0.0068	0.0553	0.0045	0.0113	0.0148	0.0188
Cu Grade	%	0.0064	0.0488	0.0042	0.0105	0.0140	0.0170
Mo Grade	%	0.0025	0.0027	0.0027	0.0030	0.0015	0.0025
Au Grade	g/t	0.0461	0.0248	0.0331	0.0123	0.0096	0.0227
<b>Total Tons- Total</b>	tonnes	47,584,715	194,979,690	431,836,314	274,370,099	289,700,970	1,238,471,788
Waste Tonnes for SR Calc		30,523,142	146,717,386	238,520,135	119,127,541	170,398,153	705,286,358
Ore Tonnes for SR Calc		17,061,573	48,262,304	193,316,179	155,242,557	119,302,817	533,185,430
Stripping Ratio		1.79	3.04	1.23	0.77	1.43	1.32

The probable reserves that will be mined annually during mining production are summarized in Table 15-37.

**Table 15-37: Production Reserve per Geological Domain**

Year	Transitional and Sulphide Ore tonnes (t)			Oxide Ore Tonnes (t)		Total Ore (t)	Total Waste (t)	Total Mined (t)	Stripping Ratio (W:O)	
	Tonnage	Grade		Tonnage	Grade					
		Cu %	Mo %	Au%		Cu %				
1	0	0.0000	0.0000	0.0000	0	0.0000	0	0	0	
2	0	0.0000	0.0000	0.0000	0	0.0000	0	0	0	
3	17,076,518	0.3968	0.0122	0.0835	7,609,884	0.3786	24,686,402	33,234,320	57,920,722	1.35
4	20,900,228	0.4122	0.0188	0.0863	4,924,068	0.4774	25,824,295	22,613,263	48,437,558	0.88
5	22,305,319	0.4386	0.0205	0.0742	5,963,189	0.3291	28,268,508	104,688,799	132,957,308	3.70
6	31,166,660	0.3135	0.0106	0.0610	11,171,419	0.3022	42,338,079	87,661,921	130,000,000	2.07
7	24,765,885	0.3280	0.0084	0.0563	10,403,646	0.3330	35,169,531	69,355,566	104,525,097	1.97
8	36,149,529	0.3037	0.0092	0.0570	5,004,140	0.2833	41,153,668	53,846,332	95,000,000	1.31
9	36,500,930	0.3106	0.0111	0.0604	2,134,890	0.2825	38,635,820	41,364,180	80,000,000	1.07
10	36,018,895	0.3146	0.0113	0.0618	2,416,902	0.2862	38,435,797	41,564,203	80,000,000	1.08
11	34,777,101	0.3196	0.0109	0.0707	735,834	0.3052	35,512,935	35,140,294	70,653,229	0.99
12	34,006,481	0.3295	0.0097	0.0774	176,181	0.3118	34,182,662	21,428,382	55,611,045	0.63
13	34,267,298	0.3435	0.0109	0.0830	80,986	0.1794	34,348,284	20,467,732	54,816,016	0.60
14	35,810,689	0.3318	0.0096	0.0836	0	0.0000	35,810,689	22,238,140	58,048,829	0.62
15	34,986,322	0.3207	0.0088	0.0797	0	0.0000	34,986,322	21,160,866	56,147,188	0.60
16	35,793,562	0.3187	0.0090	0.0691	334,875	0.2609	36,128,437	43,871,563	80,000,000	1.21
17	15,631,879	0.3516	0.0072	0.0567	3,381,437	0.2882	19,013,316	60,986,684	80,000,000	3.21
18	27,282,763	0.3454	0.0086	0.0631	1,407,922	0.2486	28,690,685	25,664,111	54,354,797	0.89
<b>Average</b>	<b>29,840,004</b>	<b>0.3356</b>	<b>0.0108</b>	<b>0.0701</b>	<b>3,484,086</b>	<b>0.3310</b>	<b>33,324,089</b>	<b>44,080,397</b>	<b>77,404,487</b>	<b>1.32</b>
<b>Total</b>	<b>477,440,056</b>				<b>55,745,374</b>		<b>533,185,430</b>	<b>705,286,358</b>	<b>1,238,471,788</b>	<b>1.32</b>



## 16 Mining Methods

### 16.1 Introduction

Conventional open pit mining methods consisting of drilling, blasting, loading and hauling will be employed at Yandera Mine. Contractor mining was determined to be more viable than an owner-operated fleet during the financial analysis of the PFS.

For the owner-operated fleet option, Atlas Copco DM30II class drill rigs were selected for drilling production holes in ore and waste. Atlas Copco FlexiRoc class drill rigs were selected for drilling holes required for perimeter control. A combination of buffer blasting and presplitting is recommended as a perimeter control measure to ensure stability of the final highwalls around the perimeter of the pit.

Blasted material will be loaded using Komatsu P&H4100 (or similar class) electric rope shovels. The shovels will load the material into Belaz 75602 (or similar class) electric dump trucks which will haul ore to the primary crusher location or ore stockpiles and waste to the waste rock dump.

The primary mining activities will be supported by ancillary activities including the following:

- bench preparation;
- pit dewatering;
- dust suppression;
- haul road construction and maintenance; and
- General housekeeping.

The mine was designed to produce 30Mt of above cut-off grade sulphide ore per annum. An additional 3Mtpa will be processed from the below cut-off grade sulphide ore stockpile or from the oxide ore stockpile when the sulphide ore sources are insufficient.

### 16.2 Open Pit Slope Design

#### 16.2.1 Hydrological Parameters

The hydrogeological conditions and conceptualization of the mine are described in the Open Pit Hydrogeological Conceptualisation and Open Pit Water Management report. The mine area is located in an area of high relief with deeply incised and steeply sloping river channels. The bedrock is hard, fractured granodiorite and quartz diorite porphyry, in a complex structural setting with a 750m wide north-west trending fault zone and several northeast-orientated transfer faults. A highly weathered zone exists to around 25m below ground level (bgl) and an oxide zone of partial and variable rock mass weathering extends to depths of over 100m bgl.

The hydraulic conductivity of the rock is considered relatively low with a geometric mean of  $8 \times 10^{-3}$  m/d. No high permeability zones have been identified to date from testing, but these may exist where faulting or fracturing is more prevalent.



The abundant rainfall will result in recharge at the ground surface, although the majority will run off to surface drainage features. Some streambed infiltration may occur, particularly in reaches at higher elevations. Groundwater discharge is likely to be directly into the deeply incised surface water features at lower elevations.

Local groundwater flow is expected to occur from areas of higher terrain, with slow drainage through the rockmass to the lower terrain, probably dominantly by limited fracture/fissure flow. Large-scale groundwater flow direction is expected to follow the regional topography and drainage pattern, and therefore likely to be easterly to northeasterly with local variation. Artesian flows are found in some drillholes and indicate upward gradients associated with areas of relatively low topographic elevation.

Relatively short flow paths and hence residence times result in good quality groundwater with moderately elevated concentrations of arsenic, boron and manganese.

Preliminary estimate of groundwater inflows to all open pits indicate an increase in inflows from 70ℓ/s after four years of operation up to 155ℓ/s at the end of mining (Year 18).

## 16.2.2 Geotechnical Parameters

The geotechnical parameters, blasting parameters and waste rock dump design are summarized in this section. The detailed geotechnical and hydrological study, which formed part of the PFS, detailed in Yandera PFS Geotechnical Report C00651-1200-MG-REP-0005.

The geotechnical engineering process adopted is in keeping with the methodology suggested by Read and Stacey (2009).

The basic process for the design of slope and foundation involved the following steps:

- Formulation of a geotechnical model for the area.
- Population of the model with relevant data.
- Division of the geotechnical model into geotechnical domains.
- Sub-division of the domains into design sectors.
- Design of the slope elements in the respective sectors.
- Assessment of the stability of the resulting slopes with respect to the acceptance criteria for the Project.
- Definition of the implementation and monitoring requirements.
- Further study if required.

A geological block model, lithological model, structural data, dedicated geotechnical information as well as geohydrological data were available to develop a geotechnical characterization model that is adequate for a PFS-level of study.

Information and design recommendations provided in the geotechnical report are based on specialist reports or supporting data provided by the client and data collected during the course of the study. The bulk of the information was obtained from the dedicated geotechnical drilling campaign conducted between August and November 2016 and from the two site visits undertaken by Advisian's Geotechnical Engineer.





During the course of the study, the design of the waste rock dump was completely changed from a rock-fill earth wall to a valley infill dump due to economic considerations.

The terrain in which mining will take place is extremely challenging with very steep natural slopes resulting in very high cut slopes in weak ground. The extent of the slopes cut into overburden was only defined after the mine design was completed. Consequently, the design and design optimization of the cut slopes in the oxidized zone and rock and soil will have to be revisited in detail during the FS. Similarly, the slope and possible slope support for all the road cut slopes (whether main access road or internal mine roads) have to be re-assessed in detail.

Geotechnical investigations have yet to be conducted at the coastal facilities. The founding conditions for the wharf, plant power generation plant and camp facilities are based on assumptions only. The fact that the Basamuk infrastructure is constructed on the same terrain is the basis for the assumption that the founding conditions are suitable.

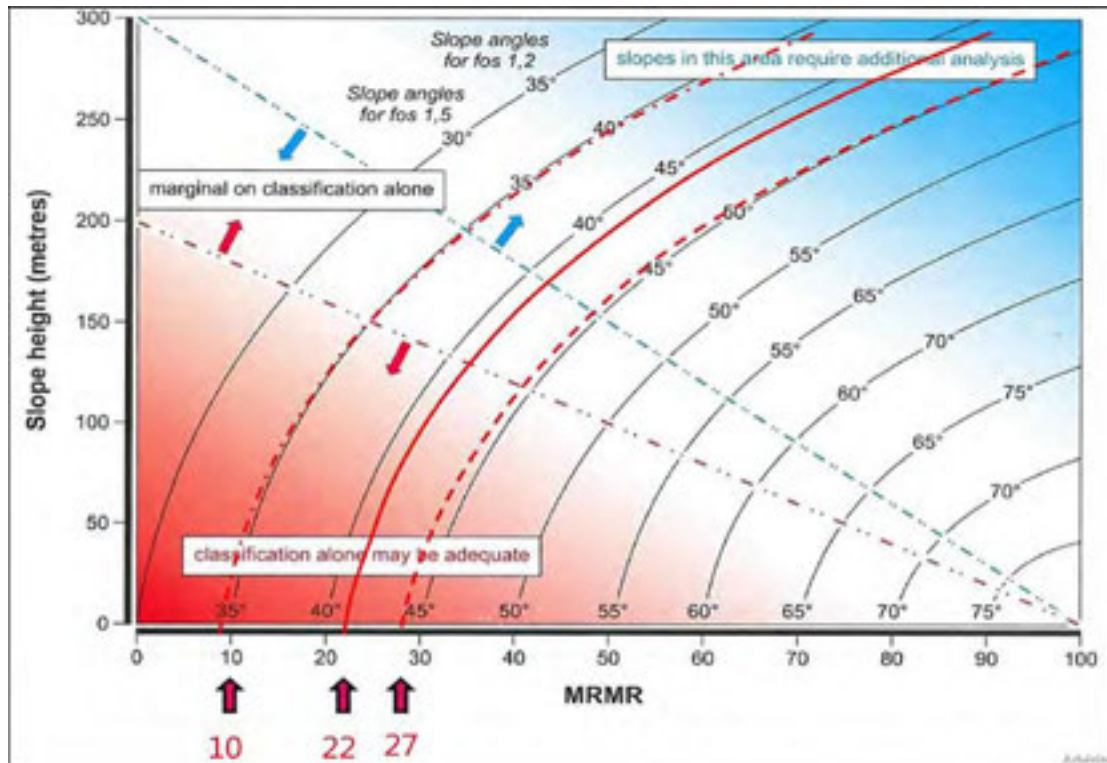
### 16.2.2.1 Seismicity

PNG is bounded by several major tectonic plates and is one of the most seismically active regions in the world. It is located on the boundary between the Indo-Australian Plate, which is moving in a northeasterly direction, and the southwesterly-moving Pacific Plate. Two smaller plates, the North and South Bismarck plates, are wedged between these two larger plates and are believed to be subducting beneath the Indo-Australian Plate. The movement of these tectonic plates has created a seismic and volcanically active region along the northern coast of PNG. The Yandera site is located on the northern portion of the Indo-Australian Plate.

PNG is subject to earthquakes, volcanos and tsunamis. However, there are no known active volcanoes close to the project site. The most recent earthquakes of any significance are the 1970 Madang and 1993 Finisterre Range events. The areas of greatest impact associated with these earthquakes were located well away from Yandera. Seismicity was addressed for the pit slope design as well as the waste rock dump design by applying a horizontal acceleration coefficient of 0.15G to the slope design.

### 16.2.2.2 Geotechnical Parameters

The geotechnical boreholes drilled during the 2016 campaign were used for the rockmass evaluation. All three of the primary rockmass classifications systems, Bieniawski's Rock Mass Rating (RMR), Laubscher's MRMR and Barton's Q-system were used for the evaluation of these 3 classification systems. As a first pass assessment of the maximum allowable slope angles that the rockmass at Yandera can support, the Hayes and Terbrugge empirical design chart shown in Figure 16-1, that uses the rockmass classification data, informed the design slope angles for the initial Whittle run. The average RMR for all the rock types encountered at Yandera is 22. The minimum rating of 10 is attributed to the oxidized zone; the maximum rating is 27, as shown in Table 16-1.



**Figure 16-1: Conceptual Slope Design Angles (After Hayes & Terbrugge)**

When plotted on the Hayes and Terbrugge chart shown in Figure 16-1, the maximum allowable slope angles can be determined for a representative Factor of Safety (FoS), which is presented in Table 16-1. The recommended design slope angles are then used as input parameters for the economical pit evaluation software (Whittle) to arrive at an economically viable pit shell.

**Table 16-1: Recommended Slope Design Angles for First Whittle Run**

	MRMR	FoS=1.5	FoS=1.2
<b>Recommended Slope Angles</b>			
<b>Lower Strength (upper 30m)</b>	10	35°	40°
<b>Recommended Overall Slope Angle</b>	22	42°	46°
<b>Max</b>	27	44°	48°

Generally, the maximum allowable pit slope angles defined in the Hayes and Terbrugge chart are downgraded by three to five degrees to allow for the effect of haul roads in the final pit design; otherwise, the final volumes of the Whittle pit and the practical pit design are quite different. The Whittle pit shells for each of the major pits, i.e. Gremi, Dimbi Omora and Imbruminda, were evaluated. The Whittle shells define the overall height of the pit shells as well as the shape of the pit shells. In the next phase of the pit slope design the different pit slope sectors was evaluated for different slope failure mechanisms and slope configurations.

### 16.2.3 Slope Design

The following assumptions were made for the proposed slope design:

- Slope design is within FoS guidelines for major structures.
- Pre-pit drilling and buffer blasting will occur along all final pit slopes.



- General good blasting practices will be followed in the pit and especially close to final pit walls.
- Slope stability monitoring systems will be installed.
- Slope management will be conducted and all possible reasonable effort will be made to ensure that geotechnical design criteria are followed; where the layout is changed, proper geotechnical diligence is applied and the loop between short- and long-term mine planning is closed.
- Access to catch benches will be maintained throughout the life of the individual pits.
- The catch benches will be cleaned periodically when material starts to build up on the berm.
- The berm wall as recommended will be constricted on all the safety benches.

The bench height for the client defines the pit and slope design based on its current equipment fleet and is fixed at 10m vertical height. The bench face angle is defined at 84° because pre-split slopes drilled at a 90° slope perform much better than vertical walls where sub-vertical joints are present.

The 3m bench offset defined for the triple bench configuration creates a safe working area at the toe of the slope for the drilling crews drilling the pre-split. The 3m also acts as a buffer to poor blasting results: it sometimes happens that toe positions are not reached and if the crest line of the next bench is too close, the holes cannot be drilled at the designed positions.

The stack slope configuration adopted consists of three 10m benches with a 3m bench offset on the middle two benches, resulting in a stack height of 30m. A catch bench is provided for at the toe of the third bench. This configuration allows for a catch and safety bench that is wide enough both to accommodate the material from a slope failure and to manoeuvre equipment for periodic cleaning. For a given bench height, the bench width is calculated using the following equation:

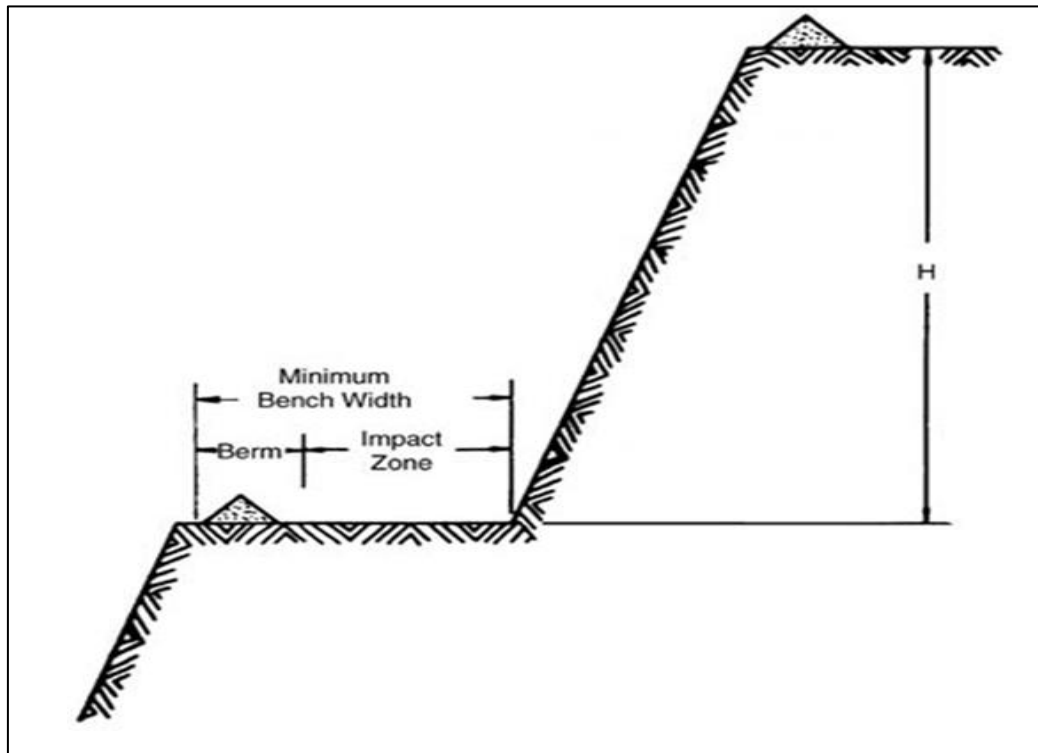
$$\text{Catch bench width (m)} = 0.2 \times \text{stack height} + 4.5\text{m}$$

The berm wall height is calculated (after Richie), using the following relationship:

$$\text{Berm wall height} = 1 + 0.04 H$$

Based on the above calculations the minimum catch bench width for the 30m stack height is 10.5m and the berm wall height is 2.2m, as depicted in Figure 16-2.

Given the climatic conditions and the general weak rockmass as well as the seismic risk, the minimum catch bench capacity was increased to 12m minimum to allow for working space behind the berm wall for periodic cleaning and the installation of the slope depressurization/dewatering array.



**Figure 16-2: Design Catch Bench Geometry**

### 16.2.3.1 Blasting Parameters

Blast design criteria used for ore and waste usually differ due to the different requirements for fragmentation and size distribution. Since the geological model is already defined in terms of ore, oxidized ore and waste, it was decided to expand the model to include oxidized waste resulting in four “geotechnical materials” that can be modelled in the block model.

With the geotechnical material defined in Figure 16-2, together with the required fragmentation for the different materials, the Kuz Ram fragmentation model was used to determine the blasting parameters for the Project.

**Table 16-2: Blasting Parameters defined for Ore and Waste**

Description	UOM	Fresh Ore	Oxidized Ore	Fresh Waste	Oxidized Waste
<b>General</b>					
Drill accuracy standard deviation	m	0.1	0.1	0.1	0.1
Face dip direction	degrees	0	0	0	0
Blasting Index		7.87	3.35	8.98	3.35
<b>Intact Rock Properties</b>					
Rock type		BX, POD	BX, POD	BX, POD	BX, POD
Rock specific gravity		2.57	2.05	2.60	2.05
Elastic Modulus	GPa	20.56	4.77	73.75	4.77
Uniaxial Compressive Strength	MPa	34.00	7.80	87.00	7.80



Description	UOM	Fresh Ore	Oxidized Ore	Fresh Waste	Oxidized Waste
<b>Jointing</b>					
Joint spacing	m	0.1	0.1	0.1	0.1
Dip of joints	degrees	45	45	80	80
Joint dip direction	degrees	0	0	0	0
In-situ block	m	3	0.3	3	0.3

### 16.2.3.2 Pit Wall Control

The pit wall control strategy proposed is based on practical experience of pre-split design on other large open pits.

The pre-split orientation and spacing of the pre-split holes differ for the different slope sectors defined for the West and East pits and are based on the rockmass strength expected in the different sectors. The proposed pre-split spacing presented in Table 16-3 is a preliminary design only. The pre-split design should be optimized in conjunction with the explosives suppliers prior to the first pre-split blast.

**Table 16-3: Proposed Pre-split Design**

Pit Area	Sector	Hole Diameter (mm)	Spacing (m)	Powder Factor (kg/m <sup>3</sup> )	Hole Length (m)	Charge Method	Charge Diameter (mm)
All	All	127	1.5-2.0	~0.5	10	decoupled	~45

The explosives manufacturers as the charge volume per charge as well as the booster should undertake the detail design of the suspended charge and detonator type specified depends on the available products. No sub drill on the pre-split is recommended.

### 16.2.3.3 Waste Rock Dump Design Parameters

The slope design for the waste rock dump evolved through a number of iterations into a design that is practical, economical and sufficiently robust to withstand the seismicity and rainfall of the area for the life of the mine and beyond.

The design is a benched design with the waste rock being dumped at right angles to the front face in stacks no higher than 50m with the final profile having a 100m-wide safety bench.

The stability analysis taking seismicity and a high-water table inside the dump into account had a FoS of 1.5 for the overall slope. Small-localized areas on the individual benches had a FoS of between 1.0 and 1.5, as shown in Figure 16-3.



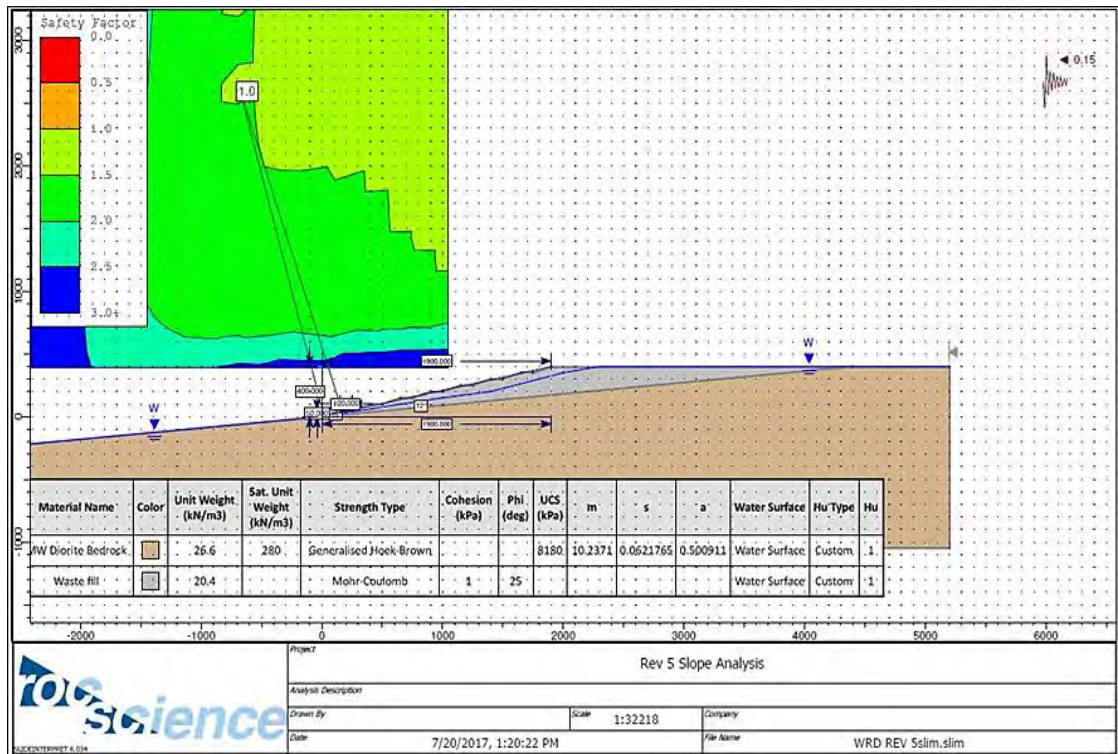


Figure 16-3: Slope Stability Analysis for the Waste Rock Dump

### 16.2.4 Detail Slope Design

The detailed slope design as based on the structural information collected. A kinematic assessment of the different slope failure mechanisms was performed based on eight slope sectors as shown in Figure 16-3 and each was evaluated for planar, wedge and toppling failure based on the four major structural orientations illustrated in Figure 16-4. The results of the kinematic assessment are presented as Table 16-5. Colour coding in the table defines green as stable and red as potentially unstable with a high likelihood of failure. Yellow is marginally unstable and orange has a moderate likelihood of failure. The matrix indicate that bench scale wedge failures are highly likely to occur along the north west and southern slopes with some stack scale failures along the northern slopes. For the most, the eastern slopes of the pits are general stable.

Table 16-4: Orientations of PM Major Structures

Feature	Dip	Dip Dir
1	65° (60-70°)	120° (119-130°)
2	60° (55-67°)	214° (212-216°)
3	55° (42-71°)	87° (80-94°)
4	65° (60-70°)	005° (000-010°)





# Conceptual Slope Design Sectors and Design Angles

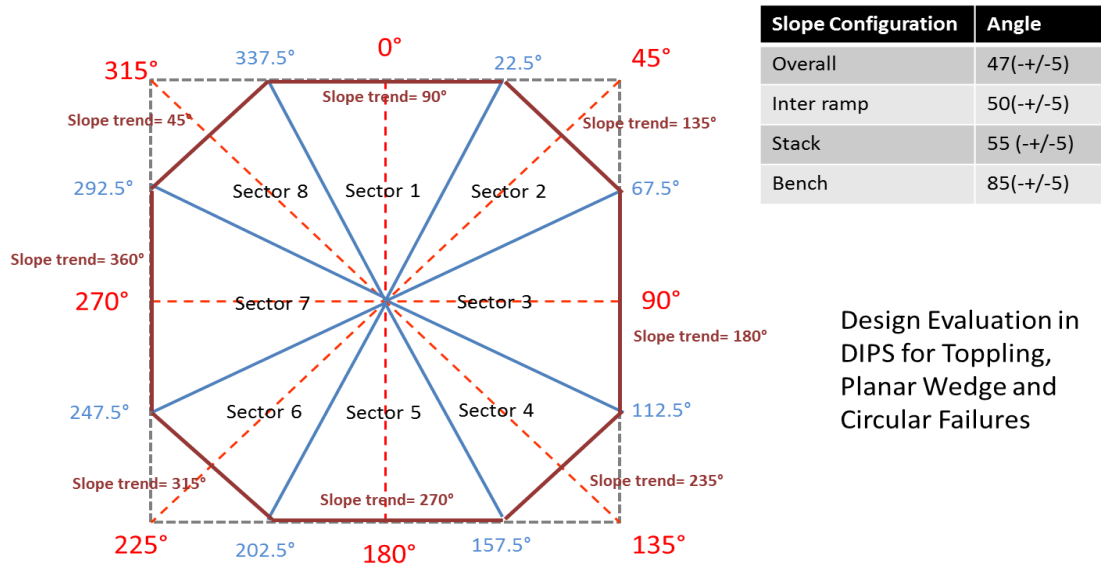


Figure 16-4: Design Sectors 1-8 with Proposed Slope Angles

Table 16-5: Results of the Kinematic Analysis for Planar Wedge and Toppling Failure Mechanisms for Mech, Stack, Inter-ramp and Overall Slope Configurations

Sectors		1	2	3	4	5	6	7	8
Planar Failure	Bench	0	25	0	0	25	0	25	25
	Stack	0	0	0	0	0	0	0	0
	Inter ramp	0	0	0	0	0	0	0	0
	Overall	0	0	0	0	0	0	0	0
Wedge Failure	Bench	33.33	50	0	0	66.67	50	83.33	83.33
	Stack	33.33	0	0	0	0	33.33	33.33	16.67
	Inter ramp	16.67	0	0	0	0	0	0	16.67
	Overall	16.67	0	0	0	0	0	0	16.67
Flexural Toppling	Bench	25	0	25	25	0	25	0	0
	Stack	0	0	0	0	0	0	0	0
	Inter ramp	0	0	0	0	0	0	0	0
	Overall	0	0	0	0	0	0	0	0
Direct Toppling	Bench	0	33.33	0	16.67	16.67	0	16.67	0
	Stack	0	33.33	0	0	16.67	0	0	0
	Inter ramp	0	33.33	0	0	16.67	0	0	0
	Overall	0	33.33	0	0	16.67	0	0	0
Oblique Toppling	Bench	0	0	0	0	0	0	0	0
	Stack	0	0	0	0	0	0	0	0
	Inter ramp	0	0	0	0	0	0	0	0
	Overall	0	0	0	0	0	0	0	0



## 16.2.5 Slope Design Considerations

### 16.2.5.1 Mining Assumptions

The following assumptions were made for the slope design proposed:

- Slope design is within FoS guidelines for major structures.
- Pre spit drilling and buffer blasting will occur along all final pit slopes.
- General good blasting practices will be followed in the pit and especially close to final pit walls.
- Slope stability monitoring systems will be installed.
- Slope management will be conducted and all possible reasonable effort will be made to ensure that geotechnical design criteria is followed, and where the layout is changed, proper geotechnical diligence is applied and the loop between short- and long-term mine planning is closed.
- Access to catch benches is to be maintained throughout the life of the individual pits.
- The catch benches must be periodically cleaned when material start to build up on the berm.
- The berm wall as recommended should be constricted on all the safety benches.

**Table 16-6: Slope Configuration based on Required Catch Bench Capacity**

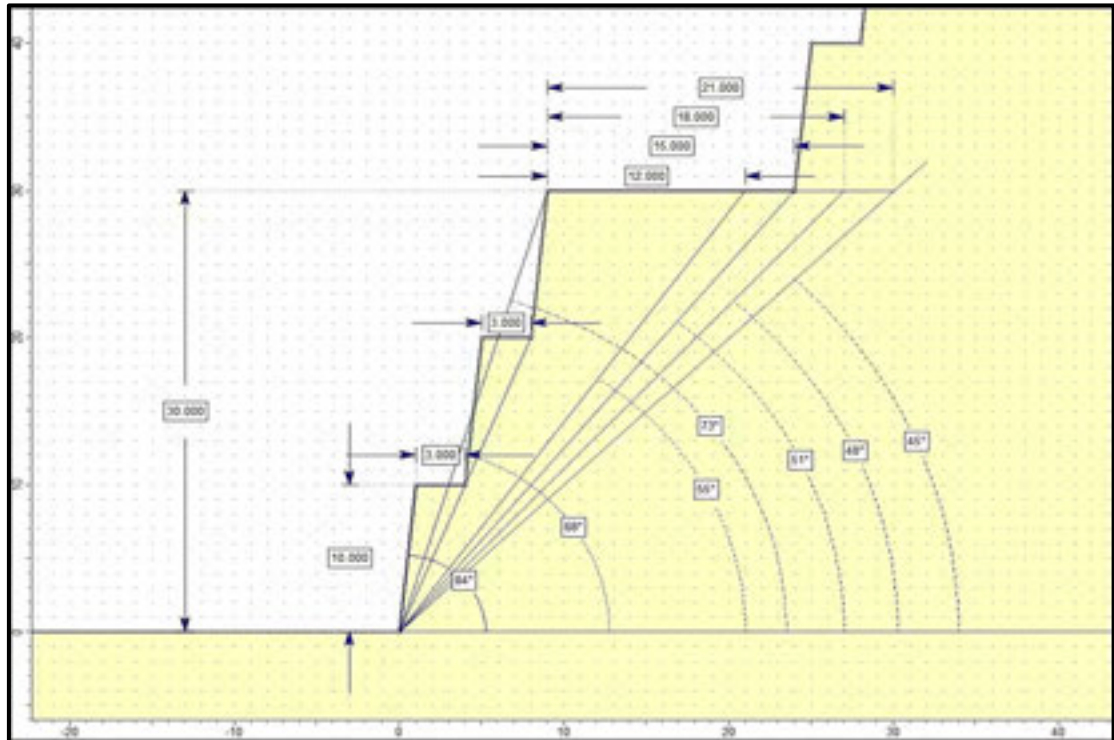
Configuration	Catch Bench Width (m)	ToT Slope Angle for 3 Bench Stack (°)
1	12	55
2	15	51
3	18	48
4	21	45

### 16.2.5.2 Inter Ramp Slope

The inter ramp slope refers to the slope section between two ramps in a slope sector. The inter ramp slope angle (toe to crest) and slope height is a consequence of the pit design and therefore not defined as part of the slope design criteria.

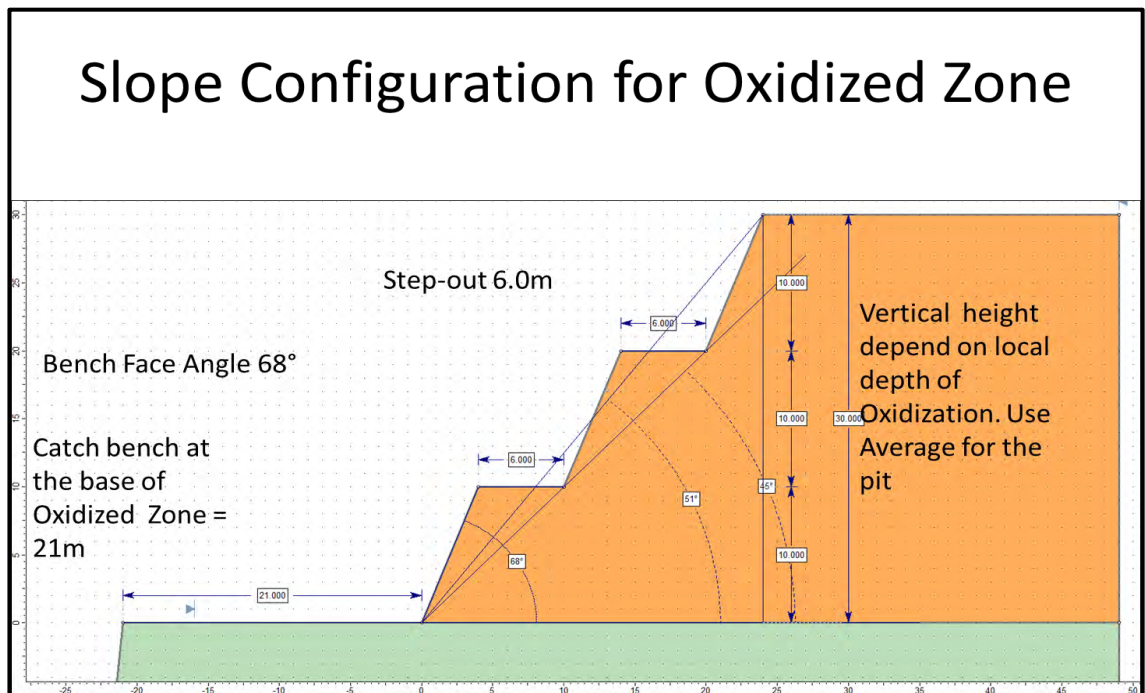
### 16.2.5.3 Basic Slope Design Parameters

To accommodate the different geotechnical conditions identified, four different basic designs are proposed as illustrated in Figure 16-5. The individual configurations are discussed below.



**Figure 16-5: Slope Configuration for the Intack Rock Slopes**

The slope configuration for the oxidized zone is defined in Figure 16-6. It is based on the average thickness of the oxidation level across the orebody. Locally the oxidation/decomposition can be deeper and along the slopes the geometry of the natural slope and the pit design may result in slopes that are much higher. These slopes will be evaluated in the next phase of the study once more in-situ testing and laboratory testing have been done to define the material properties better and the geometry of the slopes are defined.



**Figure 16-6: Slope Configuration for the Oxidized Zone**



#### **16.2.5.4 Slope Configuration 1**

For slope areas where the kinematic evaluation indicated a lower likelihood of failure a 12m catch bench at the base of the three-bench stack is designed. The stack slope is 30m high with the individual 10m high benches will be cut with an 84° face angle and a 3m step out at the base.

#### **16.2.5.5 Slope Configuration 2**

For slope areas where the kinematic evaluation indicated a higher likelihood of failure, a 15m catch bench at the base of the three-bench stack is designed. The stack slope is 30m high with the individual 15m high benches will be cut with an 84° face angle and a 3m step out at the base.

#### **16.2.5.6 Slope Configuration 3**

For slope areas where the kinematic evaluation indicated a higher likelihood of failure, an 18m catch bench at the base of the three-bench stack is designed. The stack slope is 30m high with the individual 18m high benches will be cut with an 84° face angle and a 3m step out at the base

#### **16.2.5.7 Slope Configuration 4**

For slope areas where the kinematic evaluation indicated a higher likelihood of failure, a 21m catch bench at the base of the three-bench stack is designed. The stack slope is 30m high with the individual 21m high benches will be cut with an 84° face angle and a 3m step out at the base

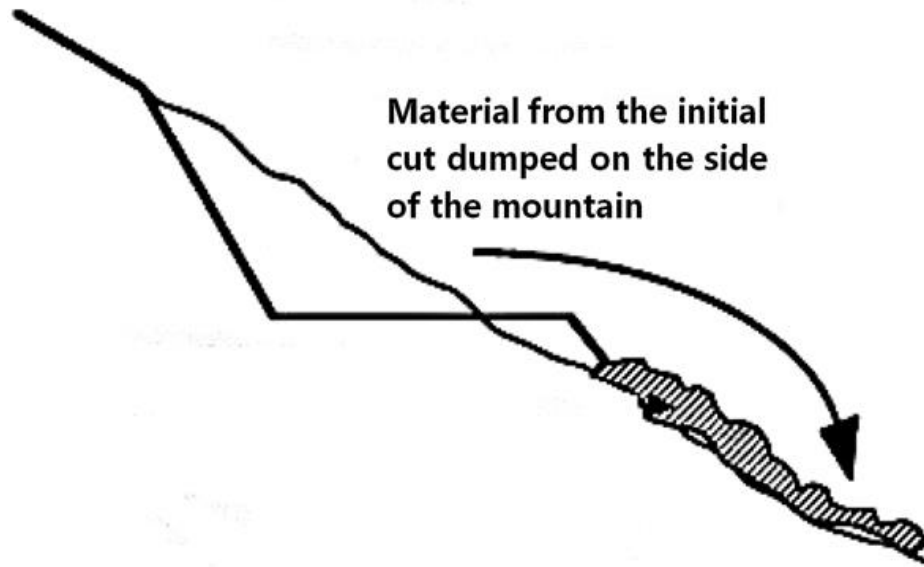
As part of the project optimization process the catch benches of the bottom three stacks in each of the pits were reduced to 10m.

### **16.3 Mining Strategy**

#### **16.3.1 Initial Haul Road Construction**

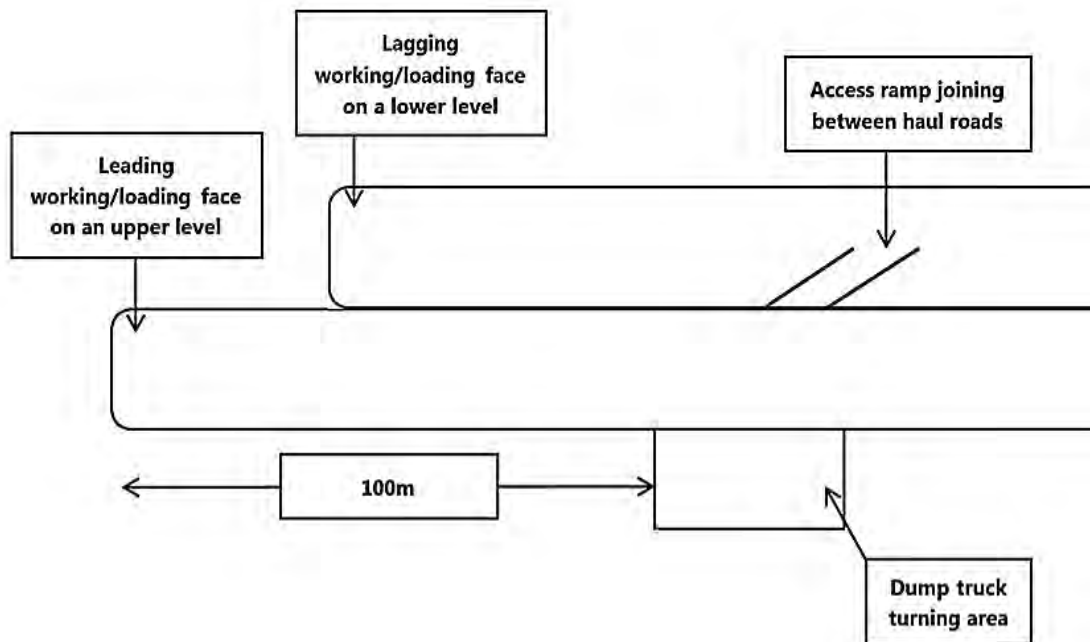
Haul road construction will be done prior to the commencement of mining to provide access to the pit areas and to put in place water management systems that will enable the mine to maintain its targeted production levels during wet seasons. The haul roads will comprise 15m and 30m wide segments. The 15m wide segments will be the initial access roads to the various hilltops from where mining will commence and the 30m wide segments will be the main and permanent production haul roads. The 15m wide access roads will serve as production haul roads until the final pit limits and permanent haul road positions are reached.

The haul roads will be developed in two stages. The first stage will involve developing an initial approximate 5m wide and 5m high cut from the mining precinct to the waste rock dump. During this stage, the excavator will dig and load material and dump it on the side of the mountain as illustrated in Figure 16-7. No dump trucks will be required as there will be no space to accommodate them.



**Figure 16-7: Development of the initial cut**

The second stage will involve extending the width of the initial cut and cutting the horizontal benches down to the required final haul road level and width. This will be accomplished by creating multiple working faces, which will be connected by access ramps as illustrated in Figure 16-8. During this stage, the excavator will be used to load material into Articulated Dump Trucks (ADT) and the dump trucks will haul the material to a designated dumping area.



**Figure 16-8: Plan view of the proposed stage two-road construction**

The capacity and number of equipment recommended for road construction is provided in Table 16-7. The equipment will also be used during mining operations to assist with load and haul operations when required.



**Table 16-7: Road Construction Equipment**

Description	Units	Cat 390F Excavator Class	Bell B40E Class Dump Truck
Volume	m <sup>3</sup>	5.7	24.0
Payload capacity	tonnes		39.0
Number of equipment required	52.9	15	45

The haul roads will be constructed over a period of two years. The volume of material that will be excavated during this period is tabulated in Table 16-8.





**Table 16-8: Haul and Hilltop Access Bulk Earthworks Quantities**

Road section	Hill-top (15m)						Normal Haul Road (30m)						Total	
	In-pit		Ex-pit		Sub-Total		In-pit		Ex-pit		Sub-Total			
	Cut (m³)	Fill (m³)	Cut (m³)	Fill (m³)	Cut (m³)	Fill (m³)	Cut (m³)	Fill (m³)	Cut (m³)	Fill (m³)	Cut (m³)	Fill (m³)	Cut (m³)	Fill (m³)
1800 to 1600 Link Road					-	-			2,891,178	130,444	2,891,178	130,444	2,891,178	130,444
1800 to 2050 Link Road					-	-	4,115,345	13,339			4,115,345	13,339	4,115,345	13,339
1800 to Omora					-	-			663,102	786,445	663,102	786,445	663,102	786,445
Dimbi North Link 1			297	65,230	297	65,230					-	-	297	65,230
Dimbi North Link 2			173	30,303	173	30,303					-	-	173	30,303
Dimbi North					-	-	137,804	3,474			137,804	3,474	137,804	3,474
Dimbi North Hilltop	832,330	2,718	208,082	679	1,040,412	3,397					-	-	1,040,412	3,397
Gremi 1600 to 1800 Link Road					-	-	1,520,424	32,420	2,280,636	48,630	3,801,060	81,050	3,801,060	81,050
Gamagu North Hilltop	323,735	48,026			323,735	48,026					-	-	323,735	48,026
Gamagu North Link 1	14,575	11,359	34,007	26,503	48,582	37,862					-	-	48,582	37,862
Gamagu North Link 2	25,741	18,802	38,611	28,202	64,352	47,004					-	-	64,352	47,004
Gamagu South Hilltop	369,949	23,155			369,949	23,155					-	-	369,949	23,155
Gremi 1800 Road					-	-	1,616,132	1,953,699			1,616,132	1,953,699	1,616,132	1,953,699
Imbrum North Hilltop	1,759,571	68,319			1,759,571	68,319					-	-	1,759,571	68,319
Imbrum South Hilltop	3,459,206	51,548			3,459,206	51,548					-	-	3,459,206	51,548
Milling Precinct to 1600 Link					-	-			785,489	61,612	785,489	61,612	785,489	61,612
Omora/Gremi Hilltop	1,128,969	69,634	1,128,969	69,634	2,257,938	139,268			1,505,292	92,846	1,505,292	92,846	3,763,230	232,114
WRD to 1800 Link					-	-			1,264,238	2,208,099	1,264,238	2,208,099	1,264,238	2,208,099
<b>Total</b>	<b>7,914,075</b>	<b>293,560</b>	<b>1,410,140</b>	<b>220,552</b>	<b>9,324,215</b>	<b>514,112</b>	<b>7,389,705</b>	<b>2,002,932</b>	<b>9,389,935</b>	<b>3,328,076</b>	<b>16,779,640</b>	<b>5,331,008</b>	<b>26,103,855</b>	<b>5,845,120</b>



## 16.3.2 Mining Method

### 16.3.2.1 Drilling and Blasting

Drill and blast techniques will be applied to fragment in-situ rock. A combination of buffer blasting and presplitting is recommended to reduce the damaging effect of the shock energy from production blasting on the highwall slopes. A single row of presplit holes will be drilled along the position of the highwall and a minimum of one row of buffer holes will be drilled in-between the presplit and production holes. The number of rows of buffer holes will vary depending on actual blasting results obtained at site.

Bulk emulsion is proposed for production and buffer blasting due to its excellent water resistant characteristics. Considering the spacing between buffer holes, waste decking is recommended for buffer blasting to reduce the amount of explosives contained in each hole and to maintain the powder factor required to fragment rock. It is recommended for each buffer hole to have two waste decks, each having a length of 2.4m and three explosive decks each with a length of 0.9m. Packaged emulsion (cartridges) is recommended for presplitting as continuous decoupled charges provide the excellent energy distribution that is required for effective presplitting (Read and Stacey, 2009). The design parameters proposed for the mine are summarized in Table 16-9.

**Table 16-9: Design Parameters**

Description	Units	Fresh Ore	Oxidized Ore	Fresh waste	Oxidized Waste
<b>General</b>					
Bench height	m	10	10	10	10
<b>Production blasting</b>					
Hole diameter	mm	152	152	152	152
Burden	m	5.0	5.0	6.0	6.0
Spacing	m	6.0	7.0	7.0	8.0
Stemming length	m	3.0	3.0	3.0	3.0
Sub-drill length	m	1.5	1.5	1.5	1.5
Total hole length to be drilled	m	11.5	11.5	11.5	11.5
Design powder factor	kg/m <sup>3</sup>	0.62	0.53	0.44	0.39
<b>Buffer blasting</b>					
Hole diameter	mm	127	127	127	127
Burden	m	2.5	2.5	3.0	3.0
Spacing	m	3.0	3.5	3.5	4.0
Stemming length	m	2.5	2.5	2.5	2.5
Sub-drill length	m	0	0	0	0
Total hole length to be drilled	m	10	10	10	10
Number of waste decks		2	2	2	2
Length of each waste deck	m	2.4	2.4	2.4	2.4
Number of explosive decks		3	3	3	3



Description	Units	Fresh Ore	Oxidized Ore	Fresh waste	Oxidized Waste
Length of each waste deck	m	0.9	0.9	0.9	0.9
Design powder factor	kg/m <sup>3</sup>	0.55	0.47	0.39	0.34
<b>Presplitting</b>					
Hole diameter	mm	127	127	127	127
Burden	m	2.5	2.5	3.0	3.0
Spacing	m	1.9	1.9	1.9	1.9
Uncharged	m	1.3	1.3	1.3	1.3
Cartridge spacing	cm	19	19	19	19
Sub-drill length	m	0	0	0	0
Total hole length to be drilled	m	10	10	10	10
Design powder factor	kg/m <sup>2</sup>	0.48	0.48	0.48	0.48

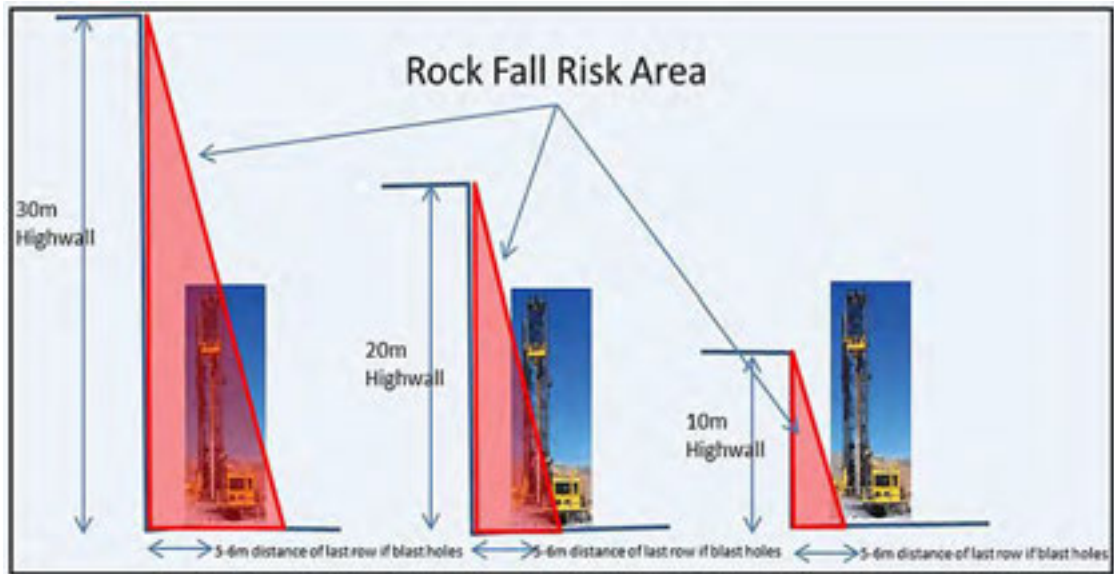
### 16.3.2.2 Slope Angles of Interim Operational Pushbacks

From a geotechnical perspective, it is not recommended to steepen the interim slope angles that will be created during the operational phases of the Project to more than a double bench configuration when scheduling the mines execution sequence as it will not be safely executable. The interim highwall is created by blasting, with no pit wall control or barring of loose rocks from the face, thus creating a high likelihood of rock falls and slope failures occurring. The seismic and climatic conditions at Yandera increase the rock fall and slope failure risk even further.

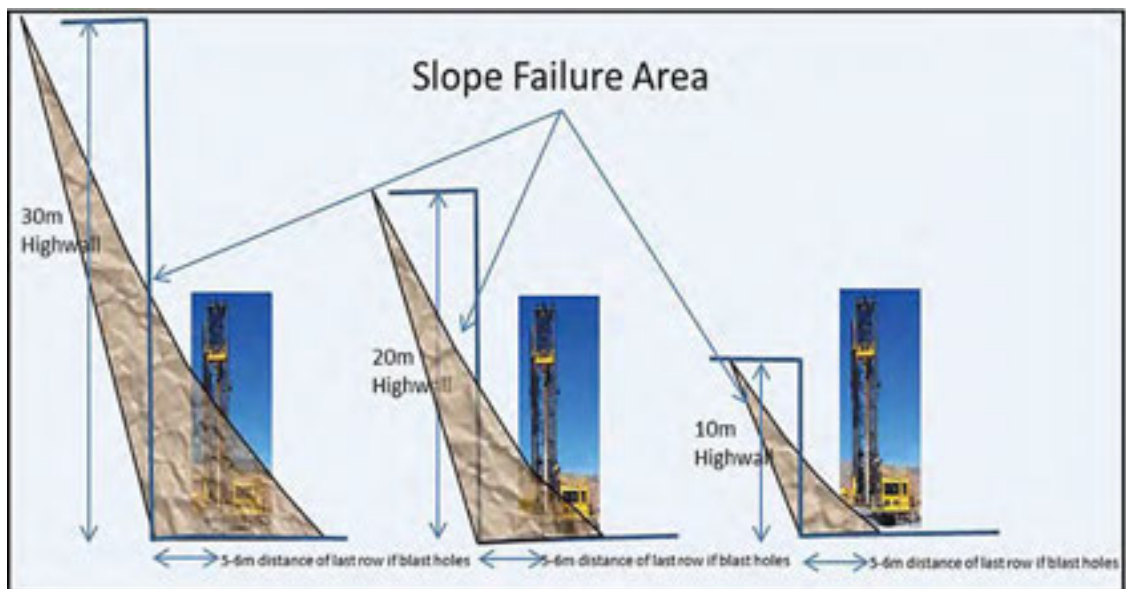
By introducing operational controls such as always, turning the cab away from the highwall and providing rock fall protection to the cab, this risk can be mitigated to an extent when considering the rock fall influence zone. When considering that, the higher the slope the more energy a rock has and the further it will roll from the face. Modelling and field trials have shown that the high risk area for a 10m high slope is 3m from the toe, for a 20m slope the risk area is 5 to 6m and for a 30m slope the high risk zone is 8 to 10m from the toe. This is indicated in Figure 16-9. Given the drill spacing for production blasting for the Project, a 20m slope height is the maximum recommended slope height.

When considering circular or planar slope failure an operator is still relatively safe when a slope failure occurs that does not cover the bottom of the cab. Modelling the height of the muck pile resulting from a 10-, 20- and 30m high slope shown the cabs of most production drill rigs, which are 2 to 2.3m above the ground level, will stand proud 5 to 6m from the highwall when slope failures up to 20m high occur, as indicated Figure 16-10. Any slope failure from a higher slope will cover a significant portion of the cab.

Due to the practical slope failure and rock fall risk, it is not recommended to create interim operational slope angles that are higher than 20m, especially considering the climatic and seismic conditions of the Project.



**Figure 16-9: Rock Fall Risk for Different High Wall Heights**



**Figure 16-10: Slope Failure Impact Area for different High Wall Heights**

### 16.3.2.3 Loading and Hauling

Mining shovels will be used to load blasted material into dump trucks. The dump trucks will haul the material to the processing plant or the waste rock dump. The type, size and number of load and haul equipment recommended for the Project are provided.

### 16.3.2.4 Open Pit Water Management

The general objectives of the water control programme for the open pits are as follows:

- Divert or remove water from the excavation to improve operational conditions, reduce mining costs, and improve safety performance. Elements to manage include:
  - Groundwater inflows.



- Direct rainfall to the open pit.
- Rainfall runoff from the open pit catchment area.
- Reduce the water pressure acting on the materials that form the pit high walls.

Water collected within the open pits will provide a water supply in support of the overall water demand for the Project.

Water that enters the open pit are considered impacted and will require appropriate treatment to meet project and legislative standards prior to discharge to environment

Due to the relatively low permeability of the bedrock and relatively low estimated rates of groundwater inflow, most dewatering will be achieved by directing groundwater inflows to sumps located at the lower levels within each pit as the mining operations progress. Advanced dewatering wells may be utilized where higher permeability features are identified and can be targeted, such as fault structures.

Depressurization will be achieved by sub-horizontal drain holes installed on benches in the open pits. Drain holes are notionally planned at an initial lateral spacing of 30m at lengths of 50 to 100m; vertical spacing will depend on the bench height. Drain hole spacing and length will vary depending on the open pit depth, geotechnical domain, structural targets, and depressurization requirements. The effectiveness of the drain holes will be measured using a network of Vibrating Wire Piezometers (VWPs) installed behind the slopes.

### 16.3.3 3D Deployment Strategy

The scheduling model for the Project has been built using the Xpac software. High-level schedules have been completed which depict the mining operations for the pits and the haul roads. The haul roads play a major role in the scheduling methodologies, as access to each of the pits need to be completed before mining can take place in that pit. In some of the pits where haul routes cross the pits to gain access to neighbouring pits (e.g. Gremi), mining operations need to be halted until neighbouring pits (e.g., Omora) have been progressed to a point where it links up with an independent haul road, in order for access roads not to be destroyed which would cut off a mining area, causing the production schedule to be practically executable.

These constraints were included in the scheduling operations.

The relevant graphics and report definitions have been completed which include Period Progress Plots, animations and detailed production reports illustrating tonnes, volumes and grades achieved from each pit or geological domain during scheduling. Destination Scheduling is also catered for and includes similar graphics and reports depicting the movement of material to the dumps and being backfilled into the Gremi/Omora pit area.

The focus of the scheduling was on the pit rankings in order to maximise project value.

Considering this, several schedules were run. Pit ranking on its own cannot be the only determining factor of a mining production schedule, as it will not result in a practically executable solution.



Other factors that need to be considered during the production scheduling include:

- Double benching is allowed but only where there are more than four contiguous mining blocks available in a row, which in the case of this PFS provide the minimum distance required establishing inter-bench temporary connecting ramp at a maximum allowable gradient of 1:10.
- Adjacent pit areas are not independent, meaning that one area cannot be mined without mining some of the adjacent pit in order to maintain the operational slope and bench configuration required for practical mining. Without this scheduling constraint, impractical and unsafe cliffs between pit areas will be created.

A base case scenario was then selected and this was used to run additional schedules on cut-off grade and blending scenarios.

Added to this was a detailed report per pit per area and per geological domain, per material type, for the cut-off grade applied.

### 16.3.3.1 Pit Ranking

To maximise the value generated from the production scheduling process, the pit design was subdivided into different pit areas. These areas were ranked based on their individual profitability potentials by creating a relative value factor per pit area. The pit rankings were based on the initial pit design and therefore reflect different ore and waste tonnages from the final design.

The relative value factor was calculated by dividing the waste into the metal content contained in each of the pit areas. This ranking was then combined with the relative size of potential reserves within a pit area to determine the deployment priority of each pit area.

It is very important to note that this method provides the guideline as to the priorities of areas within the total pit design to focus on first when developing a practically executable production schedule. As all the areas are interdependent and the total schedule has to adhere to the practical requirements of bench establishment and a safe operational slope angle, none of these mine planning areas can be mined in isolation.

There will always be overlaps with adjacent mining areas in the production schedule. Without such overlaps the production schedule will not be practically executable and thus also not NI 43-101 compliant.

**Table 16-10: Pit Ranking**

Ranking	Pit	Relative value	Cu Eq grade	Ore tonnes	Total tonnes	Percentage of Potential Reserve	Stripping Ratio
1	South1	0.45	0.35	444,887	787,351	0.1%	0.770
2	Gremi	0.42	0.41	172,456,945	339,595,343	31.4%	0.969
3	North	0.27	0.28	691,485	1,397,013	0.1%	1.020
4	Imbruminda	0.27	0.39	216,212,696	526,756,343	39.3%	1.436
5	Omora	0.27	0.43	108,073,132	282,044,167	19.7%	1.610
6	Dimbi	0.17	0.16	42,376,704	142,111,348	7.7%	2.354
7	South2	0.14	0.36	1,498,946	5,503,153	0.3%	2.671





Ranking	Pit	Relative value	Cu Eq grade	Ore tonnes	Total tonnes	Percentage of Potential Reserve	Stripping Ratio
8	Dimbi South	0.11	0.45	2,372,472	12,035,690	0.4%	4.073
9	Gamagu	0.10	0.47	5,766,036	33,376,000	1.0%	4.788
<b>Total</b>				<b>549,893,303</b>	<b>1,343,606,407</b>	<b>100.0%</b>	

### 16.3.3.2 Mining Phases

Using the principles as described for the 3D deployment strategy and pit area ranking system described above, the production schedule as illustrated from Figure 16-11 to Figure 16-28 was produced. Prior to the commencement of the production schedule, the hill top access and haul roads have to be developed, contributing 35,797,365 total tonnes to the pre-production schedule, of which 7,312,022 tonnes are included as ore in the Probable Reserve Estimate, and the remaining 28,485,342 tonnes consist of waste rock.

A total of 533,185,430t ore is produced from the production schedule. A total of 705,286,358t waste rock will be produced over the life of the mine. The tonnage that will be placed in the waste rock dump amounts to 531,364,993t and the remaining tonnages (173,921,366t) will be backfilled into the Gremi and Omora pits.



**Figure 16-11: Commencement of Mining after Establishment of Hill Top Access and Haul Road Network (Start of Year 3 – 2022)**

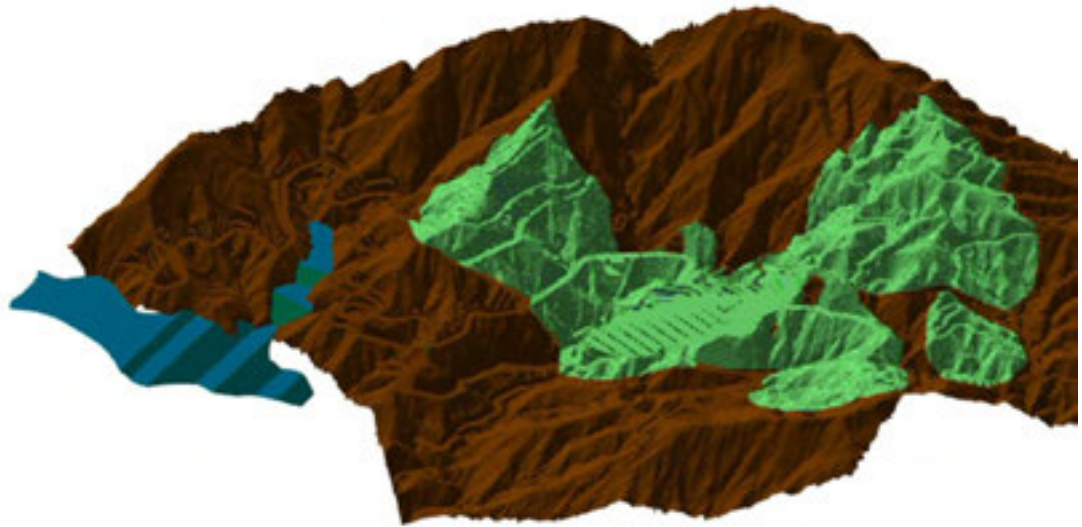


Figure 16-12: End of the First Year of Production (Year 3 – 2022)



Figure 16-13: End of the Second Year of Production (Year 4 – 2023)

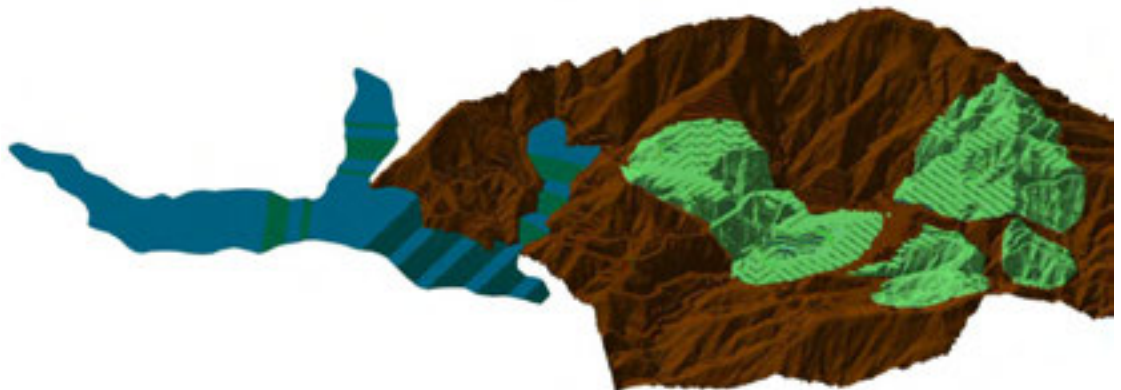


Figure 16-14: End of the Third Year of Production (Year 5 – 2024)



Figure 16-15: End of the Fourth Year of Production (Year 6 – 2025)

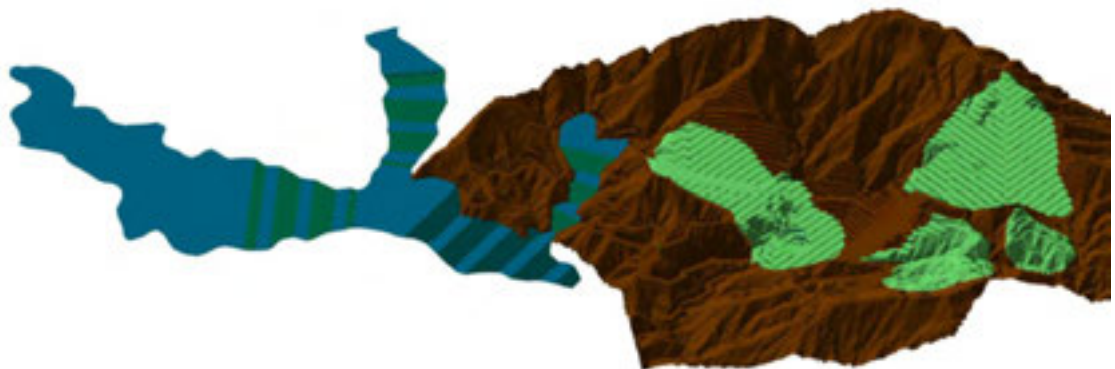


Figure 16-16: End of the Fifth Year of Production (Year 7 – 2026)



Figure 16-17: End of the Sixth Year of Production (Year 8 – 2027)

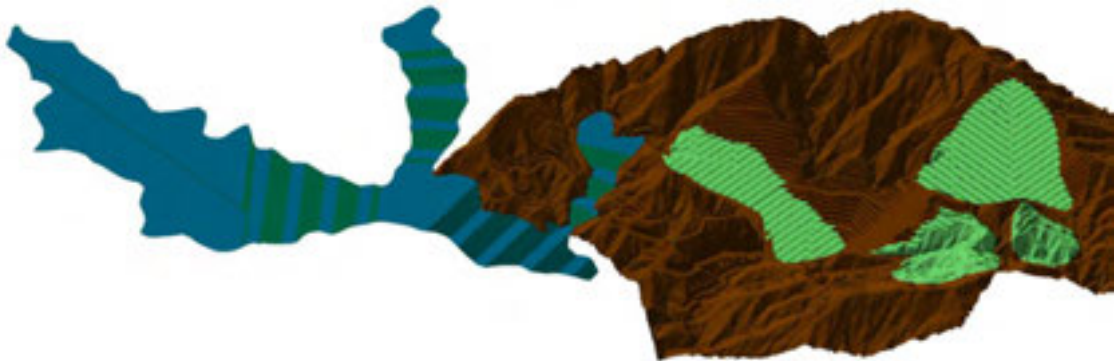


Figure 16-18: End of the Seventh Year of Production (Year 9 – 2028)





Figure 16-19: End of the Eighth Year of Production (Year 10 – 2029)

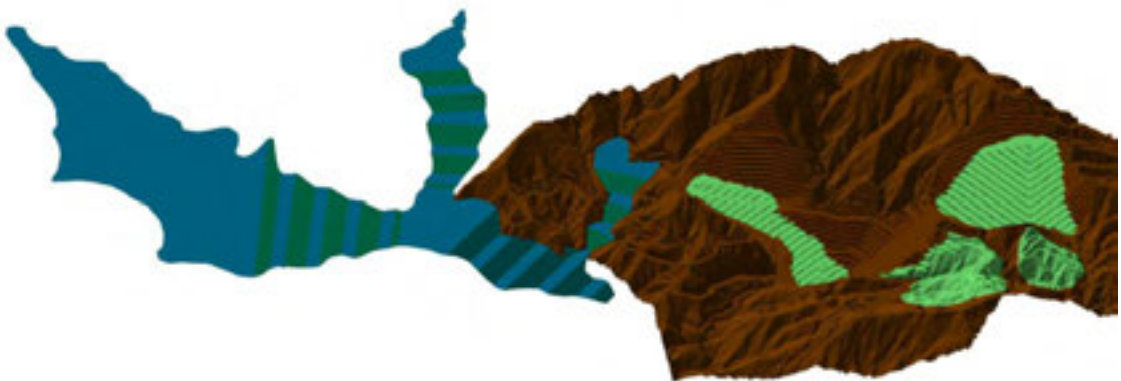


Figure 16-20: End of the Ninth Year of Production (Year 11 – 2030)

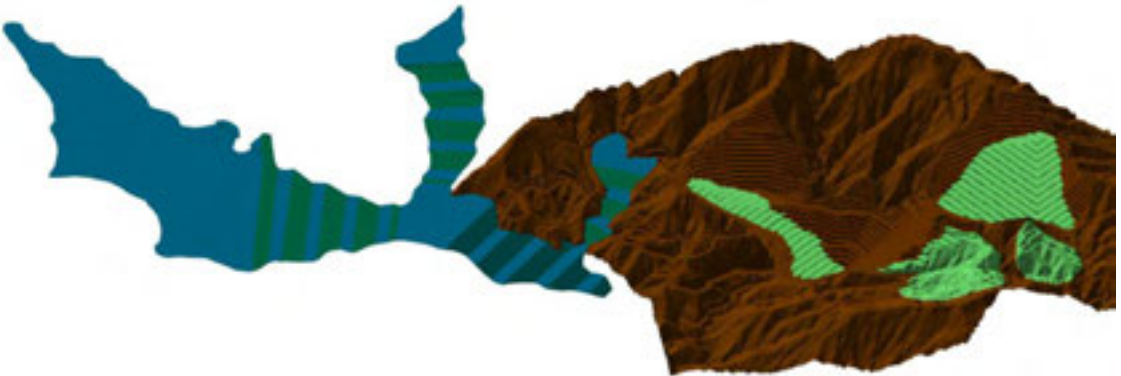
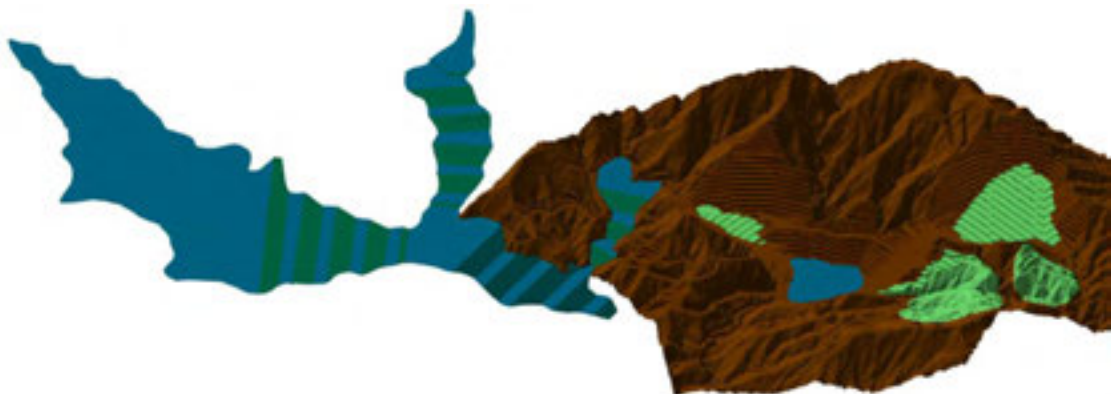


Figure 16-21: End of the Tenth Year of Production (Year 12 – 2031)



**Figure 16-22: End of the Eleventh Year of Production (Year 13 – 2032)**



**Figure 16-23: End of the Twelfth Year of Production (Year 14 – 2033) –  
Backfilling into Gremi Commences**



**Figure 16-24: End of the Thirteenth Year of Production  
(Year 15 – 2034) – Backfilling into Gremi**



**Figure 16-25: End of the Fourteenth Year of Production  
(Year 16 – 2035) - Backfilling into Gremi**

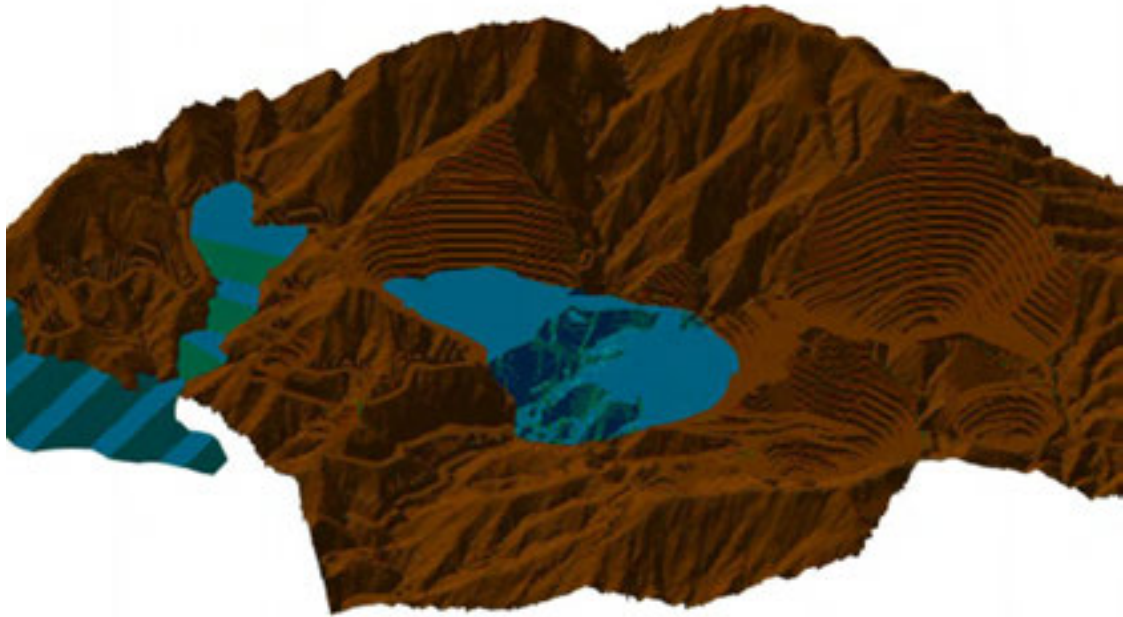


**Figure 16-26: End of the Fifteenth Year of Production (Year 17 – 2036) - Backfilling into Gremi**



**Figure 16-27: End of the Sixteenth Year of Production (Year 18 – 2037) - Backfilling into Gremi**





**Figure 16-28: End of the Sixteenth Year of Production (Year 18 – 2037) after Backfilling into Gremi**

## **16.3.4 Production Scheduling**

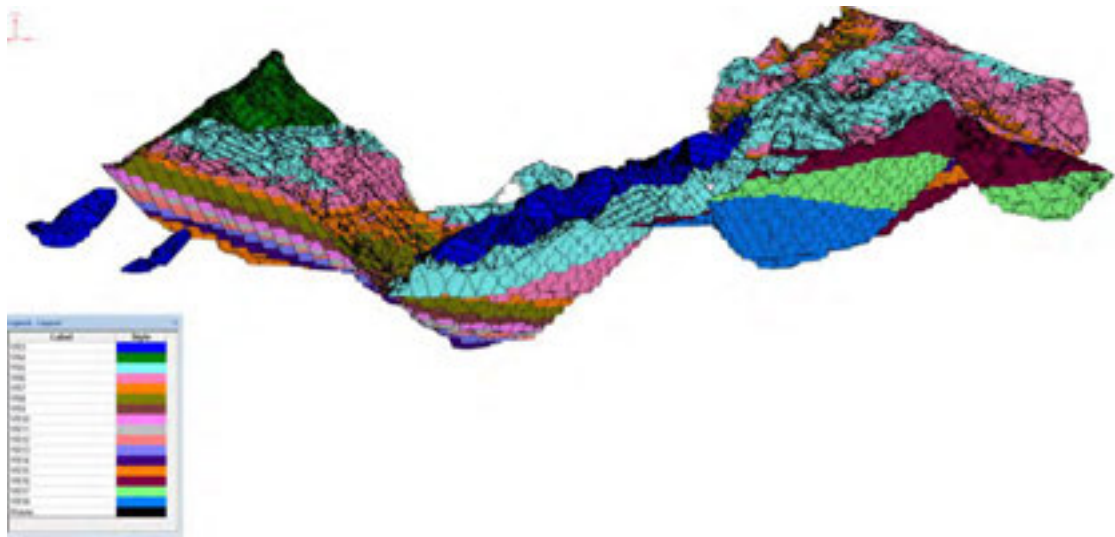
### **16.3.4.1 Scheduling Methodology**

The scheduling model for the Project was built using the Xpac software. High-level schedules were completed to depict the mining operations for the pits and the haul roads. The haul roads play a major role in the scheduling methodologies, as access to each pit needs to be completed before mining can take place in that pit. Access to the haul route system from each production block needed to be demonstrated through animation before a production schedule was accepted as meeting the NI 43-101 requirement of being practically executable. These constraints were included in the scheduling operations.

The scheduling of the pits was done on 50 by 50m blocks due to the following reasons:

- The schedules could be generated faster due to the database having fewer records to schedule
- The block size is more realistic based on what will practically be mined in the pit

The relevant graphics and report definitions were completed which include period progress plots (Figure 16-29 and Figure 16-30), production schedule animations (Figure 16-11 to Figure 16-28) and detailed production reports illustrating tonnes, volumes and grades achieved from each pit during scheduling. Destination scheduling was also catered for and includes similar graphics and reports depicting the movement of material to the waste rock dump and backfilling into the pit.



**Figure 16-29: Period Progress Plot for the Pit**



**Figure 16-30: Period Progress Plot – Waste Dumping**

### 16.3.4.1.1 Calendar

The Xpac calendar database was used to establish all time-related data that was required as part of the scheduling parameters. The calendar includes data such as the production rates for each loading tool as well as factors that influence the working hours of each loading tool such as rain delays as provided.

The Initial haul road construction in the Xpac calendar is impacted more by rain delays, as road construction and water management systems will not yet be in place. Steady State production on the other hand, when these mitigations are in place, will be impacted minimally by adverse weather conditions, as it is assumed that the engineered solutions will allow the production rate to be maintained relatively consistently during heavy rainfall events.



### 16.3.4.1.2 Schedule Setup

Most of the detail in the schedules produced arises from the schedule setup in Xpac. It contains, inter alia, the following:

- The definition of the mining rules (called “dependencies”) that determine the mining sequence of each pit.
- Establishing the individual loaders that will be used for scheduling each pit, along with the defined production rates to be used for each loader.
- Controlling the timing of the start-up of each pit and pushback using Period Constraints.
- Controlling the destination (dump or stockpile) to which each material type is sent.
- Ensuring that the haul route connections between all blocks mined and their destinations are continuously maintained in order to illustrate practical mining, and to provide assurance that the correct haul route profiles are applied during the Haul Infinity process.

### 16.3.4.1.3 Graphics

Graphical plots were created in Xpac to allow the user to view selected relevant information. These included plots with user-defined legends that show for each reserve block the Cu grade, distribution of material types and other parameters. The most useful graphical plot is the animation, which is used to visualise the mining sequence produced.

### 16.3.4.1.4 Reporting

Customized reports were created in order to view the results of the schedules that were created.

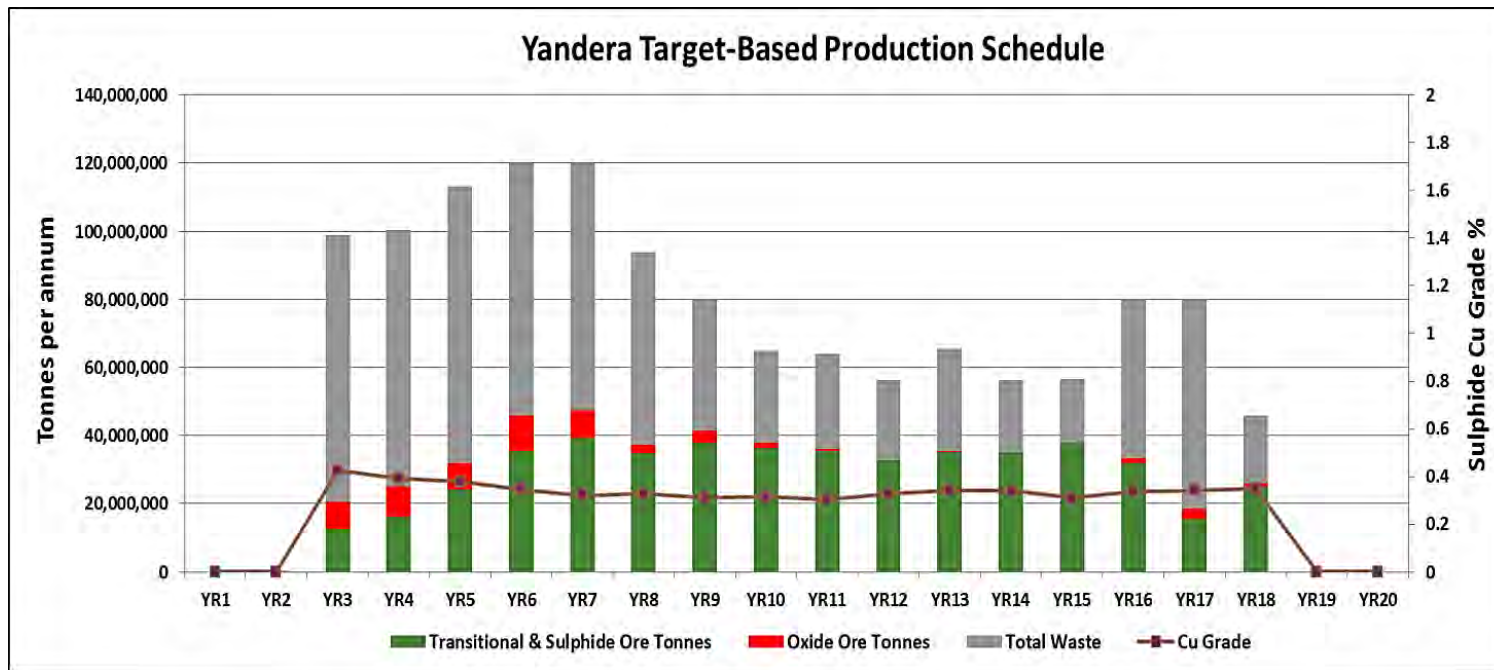
The scheduling of the pits was initially done on 50 by 50m blocks. The reason for this were twofold in that firstly the schedules could be generated faster due to the database having fewer records to schedule, and secondly this is a more realistic block size based on what will practically be mined in the pit.

### 16.3.4.2 Production Scheduling

An initial production schedule as depicted in Table 16-11 and Figure 15-1 was developed on the initial pit design. This was updated after design optimizations on the access, haul road system, and pit designs. The schedule was adjusted to maximise NPV, by limiting waste mining in the initial production years, whilst at the same time targeting higher grade accessible ore. This was accomplished through the detailed design, costing and scheduling of the start-up pits in Gremi, Omora and Imbruminda. The updated production schedule is depicted in Table 16-12 and Figure 16-32 based on the mine planning pit areas.

**Table 16-11: Initial Target-Based Production Schedule (Year 1 = 2020)**

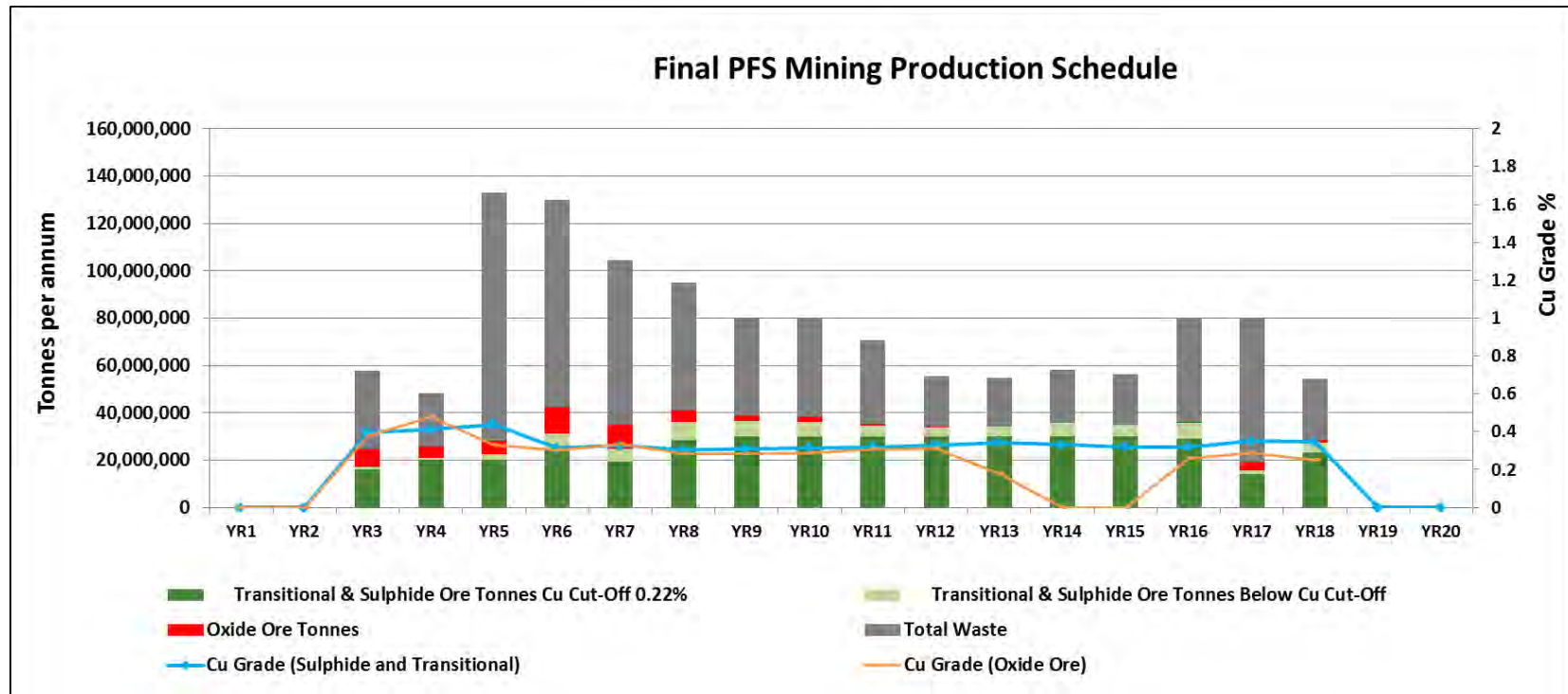
	YR1	YR2	YR3	YR4	YR5	YR6	YR7	YR8	YR9	YR10	YR11	YR12	YR13	YR14	YR15	YR16	YR17	YR18	YR19
Transitional & Sulphide Ore Tonnes	0	0	12,634,878	16,098,569	24,178,606	35,600,394	39,289,476	34,792,199	37,814,200	36,495,425	35,479,463	32,695,962	35,308,318	35,051,418	37,725,331	31,970,135	15,555,765	24,922,227	0
Cu Grade	0.00	0.00	0.42	0.39	0.38	0.35	0.32	0.33	0.31	0.31	0.30	0.33	0.34	0.34	0.31	0.34	0.34	0.35	0.00
Mo Grade	0.00	0.00	0.01	0.02	0.02	0.01	0.01	0.01	0.01	0.01	0.01	0.01	0.01	0.01	0.01	0.01	0.01	0.01	0.00
Au Grade	0.00	0.00	0.10	0.08	0.06	0.06	0.06	0.07	0.06	0.07	0.06	0.08	0.09	0.08	0.08	0.08	0.05	0.06	0.00
Oxide Ore Tonnes	0	0	8,056,465	8,974,234	7,853,212	10,204,938	8,044,219	2,478,243	3,572,865	1,355,510	733,401	126,396	31,925	0	0	1,294,147	2,911,196	937,106	0
Cu Grade	0.00	0.00	0.38	0.38	0.32	0.33	0.33	0.30	0.30	0.27	0.29	0.29	0.33	0.00	0.00	0.33	0.26	0.25	0.00
Total Ore	0	0	20,691,343	25,072,803	32,031,818	45,805,332	47,333,695	37,270,442	41,387,065	37,850,935	36,212,864	32,822,358	35,340,243	35,051,418	37,725,331	33,264,282	18,466,961	25,859,333	0
	0.00	0.00	0.41	0.39	0.36	0.34	0.32	0.33	0.31	0.31	0.30	0.33	0.34	0.34	0.31	0.34	0.33	0.35	0.00
Total Waste	0	211,308	78,181,399	75,382,726	81,043,239	74,194,668	72,666,305	56,466,254	38,612,935	27,013,715	27,858,946	23,467,064	30,055,836	21,123,730	18,750,257	46,735,718	61,533,039	19,991,186	0
Total Mined	0	211,308	98,872,742	100,455,529	113,075,057	120,000,000	120,000,000	93,736,696	80,000,000	64,864,650	64,071,811	56,289,423	65,396,079	56,175,149	56,475,588	80,000,000	80,000,000	45,850,519	0



**Figure 16-31: Initial Target-Based Production Schedule (Year 1 = 2020)**

**Table 16-12: Mine Planning Based Production Schedule (Year 1 = 2020)**

	YR1	YR2	YR3	YR4	YR5	YR6	YR7	YR8	YR9	YR10	YR11	YR12	YR13	YR14	YR15	YR16	YR17	YR18
Transitional & Sulphide Ore Tonnes	0	0	17,076,518	20,900,228	22,305,319	31,166,660	24,765,885	36,149,529	36,500,930	36,018,895	34,777,101	34,006,481	34,267,298	35,810,689	34,986,322	35,793,562	15,631,879	27,282,763
Cu Grade (Sulphide and Transitional)	0	0	0.396794093	0.41	0.44	0.31	0.33	0.30	0.31	0.31	0.32	0.33	0.34	0.33	0.32	0.32	0.35	0.35
Mo Grade	0	0	0.012249402	0.02	0.02	0.01	0.01	0.01	0.01	0.01	0.01	0.01	0.01	0.01	0.01	0.01	0.01	0.01
Au Grade	0	0	0.083461532	0.09	0.07	0.06	0.06	0.06	0.06	0.06	0.07	0.08	0.08	0.08	0.08	0.07	0.06	0.06
Oxide Ore Tonnes	0	0	7,609,884	4,924,068	5,963,189	11,171,419	10,403,646	5,004,140	2,134,890	2,416,902	735,834	176,181	80,986	0	0	334,875	3,381,437	1,407,922
Cu Grade (Oxide Ore)	-	-	0.38	0.48	0.33	0.30	0.33	0.28	0.28	0.29	0.31	0.31	0.18	-	-	0.26	0.29	0.25
<b>Total Ore</b>	<b>0</b>	<b>0</b>	<b>24,686,402</b>	<b>25,824,295</b>	<b>28,268,508</b>	<b>42,338,079</b>	<b>35,169,531</b>	<b>41,153,668</b>	<b>38,635,820</b>	<b>38,435,797</b>	<b>35,512,935</b>	<b>34,182,662</b>	<b>34,348,284</b>	<b>35,810,689</b>	<b>34,986,322</b>	<b>36,128,437</b>	<b>19,013,316</b>	<b>28,690,685</b>
			0.39	0.42	0.42	0.31	0.33	0.30	0.31	0.32	0.33	0.34	0.33	0.32	0.32	0.32	0.34	0.34
<b>Total Waste</b>	<b>0</b>	<b>0</b>	<b>33,234,320</b>	<b>22,613,263</b>	<b>104,688,799</b>	<b>87,661,921</b>	<b>69,355,566</b>	<b>53,846,332</b>	<b>41,364,180</b>	<b>41,564,203</b>	<b>35,140,294</b>	<b>21,428,382</b>	<b>20,467,732</b>	<b>22,238,140</b>	<b>21,160,866</b>	<b>43,871,563</b>	<b>60,986,684</b>	<b>25,664,111</b>
<b>Total Mined</b>	<b>0</b>	<b>0</b>	<b>57,920,722</b>	<b>48,437,558</b>	<b>132,957,308</b>	<b>130,000,000</b>	<b>104,525,097</b>	<b>95,000,000</b>	<b>80,000,000</b>	<b>80,000,000</b>	<b>70,653,229</b>	<b>55,611,045</b>	<b>54,816,016</b>	<b>58,048,829</b>	<b>56,147,188</b>	<b>80,000,000</b>	<b>80,000,000</b>	<b>54,354,797</b>
<b>Ore Tons - Total</b>	<b>0</b>	<b>0</b>	<b>17,076,518</b>	<b>20,900,228</b>	<b>22,305,319</b>	<b>31,166,660</b>	<b>24,765,885</b>	<b>36,149,529</b>	<b>36,500,930</b>	<b>36,018,895</b>	<b>34,777,101</b>	<b>34,006,481</b>	<b>34,267,298</b>	<b>35,810,689</b>	<b>34,986,322</b>	<b>35,793,562</b>	<b>15,631,879</b>	<b>27,282,763</b>
Transitional & Sulphide Ore Tonnes Cu Cut-Off 0.22%	0	0	16,071,073	20,000,000	19,985,703	24,643,820	19,350,375	28,468,859	29,874,969	30,000,000	30,000,000	30,000,000	30,000,000	30,000,000	30,000,000	29,068,153	14,083,697	23,131,023
Transitional & Sulphide Ore Tonnes Below Cu Cut-Off	0	0	1,005,445	900,228	2,319,616	6,522,840	5,415,509	7,680,670	6,625,961	6,018,895	4,777,101	4,006,481	4,267,298	5,810,689	4,986,322	6,725,408	1,548,181	4,151,740



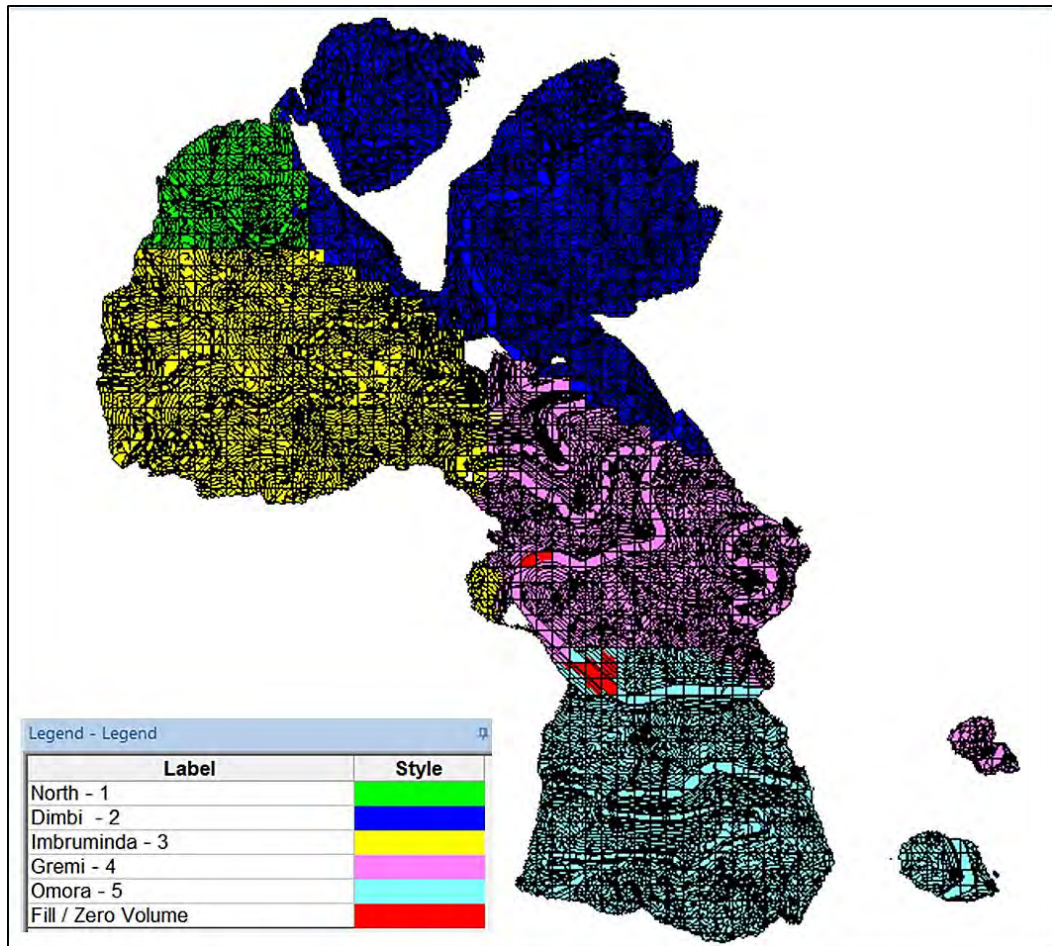
**Figure 16-32: Mine Planning Based Production Schedule (Year 1 = 2020)**





### 16.3.4.3 Final Production Scheduling

The final production schedules, which are based on geological domains defined for the Project, in order to correctly apply recoveries in the financial evaluation, are provided from Table 16-13 to Table 16-18 and from Figure 16-34 to Figure 16-39.

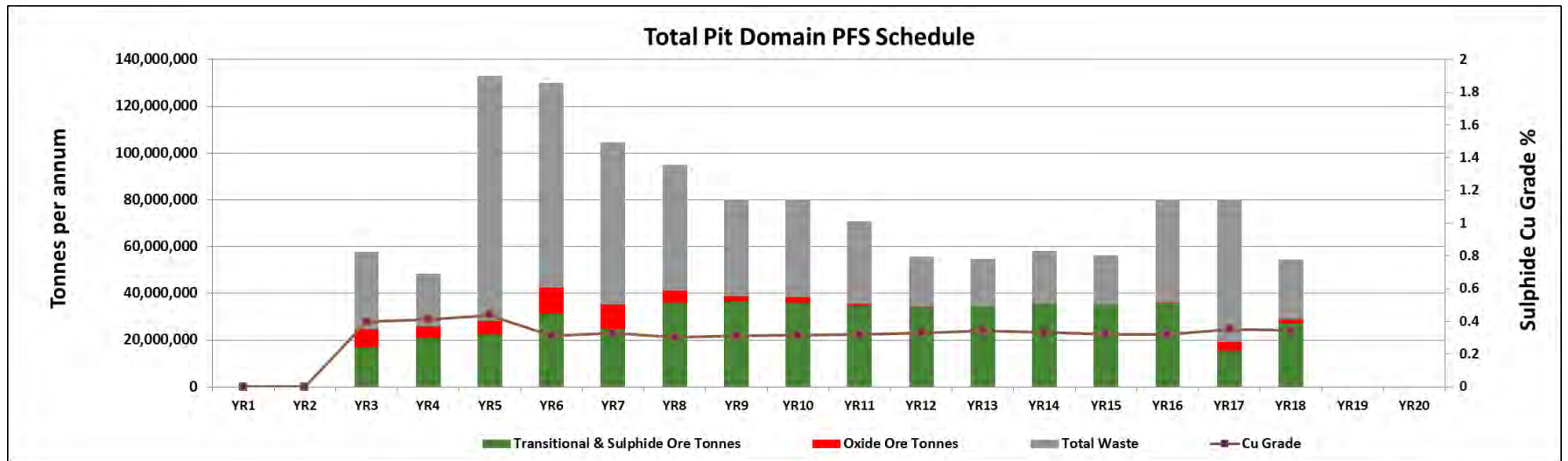


**Figure 16-33: Geological Domains used for Production Scheduling**



**Table 16-13: Production Schedule of all Geological Domains (Year 1 = 2020)**

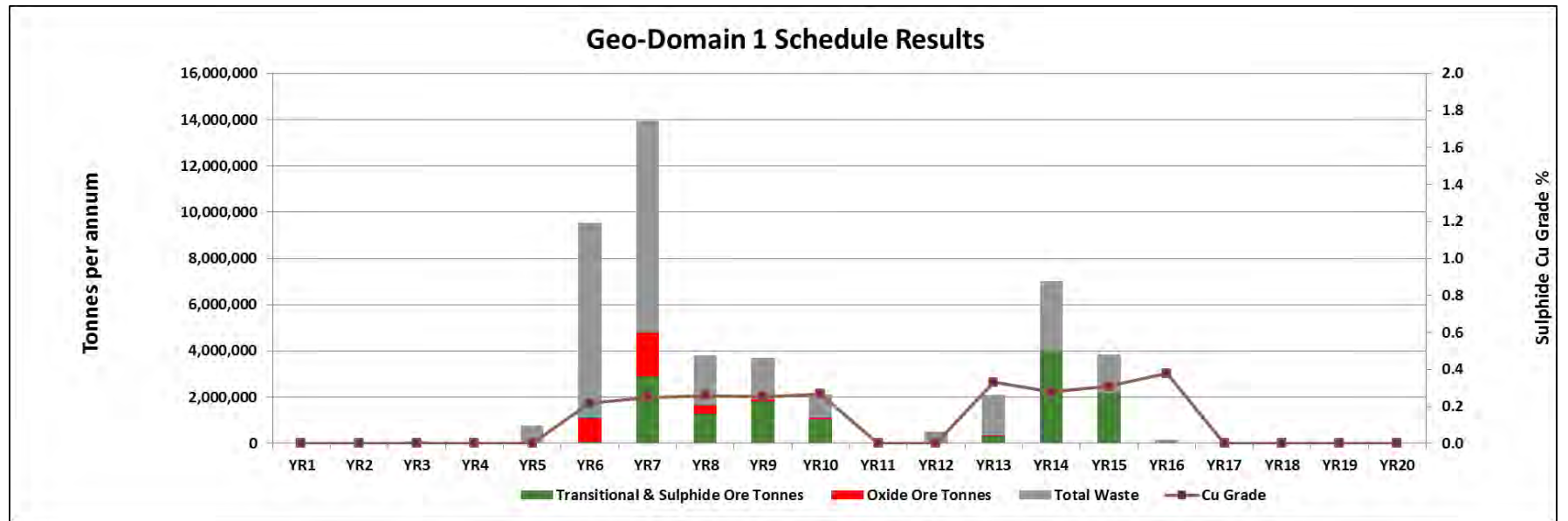
	YR1	YR2	YR3	YR4	YR5	YR6	YR7	YR8	YR9	YR10	YR11	YR12	YR13	YR14	YR15	YR16	YR17	YR18
Transitional & Sulphide Ore Tonnes	0	0	17,076,518	20,900,228	22,305,319	31,166,660	24,765,885	36,149,529	36,500,930	36,018,895	34,777,101	34,006,481	34,267,298	35,810,689	34,986,322	35,793,562	15,631,879	27,282,763
Cu Grade	0	0	0.3968	0.41	0.44	0.31	0.33	0.30	0.31	0.31	0.32	0.33	0.34	0.33	0.32	0.32	0.35	0.35
Mo Grade	0	0	0.0122	0.0188	0.0205	0.0106	0.0084	0.0092	0.0111	0.0113	0.0109	0.0097	0.0109	0.0096	0.0088	0.0090	0.0072	0.0086
Au Grade	0	0	0.0835	0.0863	0.0742	0.0610	0.0563	0.0570	0.0604	0.0618	0.0707	0.0774	0.0830	0.0836	0.0797	0.0691	0.0567	0.0631
Oxide Ore Tonnes	0	0	7,609,884	4,924,068	5,963,189	11,171,419	10,403,646	5,004,140	2,134,890	2,416,902	735,834	176,181	80,986	0	0	334,875	3,381,437	1,407,922
Cu Grade	-	-	0.38	0.48	0.33	0.30	0.33	0.28	0.28	0.29	0.31	0.31	0.18	-	-	0.26	0.29	0.25
Total Ore	0	0	24,686,402	25,824,296	28,268,508	42,338,079	35,169,531	41,153,669	38,635,820	38,435,797	35,512,935	34,182,662	34,348,284	35,810,689	34,986,322	36,128,437	19,013,316	28,690,685
	-	-	0.39	0.42	0.42	0.31	0.33	0.30	0.31	0.31	0.32	0.33	0.34	0.33	0.32	0.32	0.34	0.34
Total Waste	0	0	33,234,320	22,613,263	104,688,799	87,661,921	69,355,566	53,846,332	41,364,180	41,564,203	35,140,294	21,428,382	20,467,732	22,238,140	21,160,866	43,871,563	60,986,684	25,664,111
Total Mined	0	0	57,920,722	48,437,559	132,957,307	130,000,000	104,525,097	95,000,001	80,000,000	80,000,000	70,653,229	55,611,044	54,816,016	58,048,829	56,147,188	80,000,000	80,000,000	54,354,796



**Figure 16-34: Production Schedule of all Geological Domains (Year 1 = 2020)**

**Table 16-14: North (Geo-Domain 1) Production Schedule (Year 1 = 2020)**

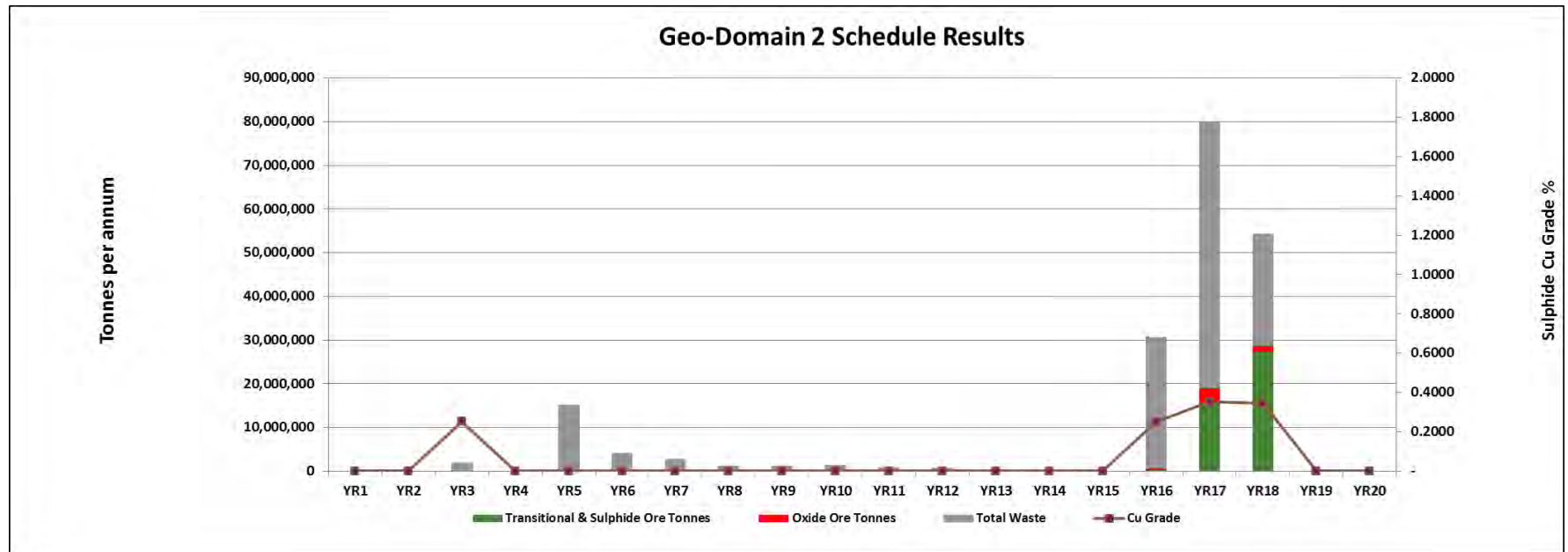
	YR1	YR2	YR3	YR4	YR5	YR6	YR7	YR8	YR9	YR10	YR11	YR12	YR13	YR14	YR15	YR16	YR17	YR18
Transitional & Sulphide Ore Tonnes	0	0	0	0	0	63,050	2,908,121	1,290,097	1,813,583	1,055,749	0	0	321,581	3,987,686	2,150,865	35,970	0	0
Cu Grade	-	-	-	-	-	0.22	0.25	0.26	0.25	0.27	-	-	0.33	0.28	0.31	0.38	-	-
Mo Grade	-	-	-	-	-	0.00	0.01	0.01	0.01	0.01	-	-	0.01	0.01	0.01	0.01	-	-
Au Grade	-	-	-	-	-	0.06	0.08	0.10	0.10	0.12	-	-	0.16	0.12	0.13	0.14	-	-
Oxide Ore Tonnes	0	0	0	0	0	1,034,811	1,869,714	354,013	112,463	47,869	0	0	16,000					
Cu Grade	-	-	-	-	-	0.21	0.24	0.27	0.30	0.32	-	-	0.31					
Total Ore	0	0	0	0	0	1,097,861	4,777,835	1,644,110	1,926,046	1,103,618	0	0	337,581	3,987,686	2,150,865	35,970	0	0
	-	-	-	-	-	0.21	0.24	0.26	0.26	0.27	-	-	0.33	0.28	0.31	0.38	-	-
Total Waste	0	0	83,195	0	754,045	8,435,438	9,163,489	2,171,594	1,778,589	1,020,767	0	500,644	1,755,247	3,036,437	1,690,693	133,003	0	0
Total Mined	0	0	83,195	0	754,045	9,533,299	13,941,324	3,815,704	3,704,635	2,124,385	0	500,644	2,092,828	7,024,123	3,841,558	168,973	0	0



**Figure 16-35: North (Geo-Domain 1) Production Schedule (Year 1 = 2020)**

**Table 16-15: Dimbi (Geo-Domain 2) Production Schedule (Year 1 = 2020)**

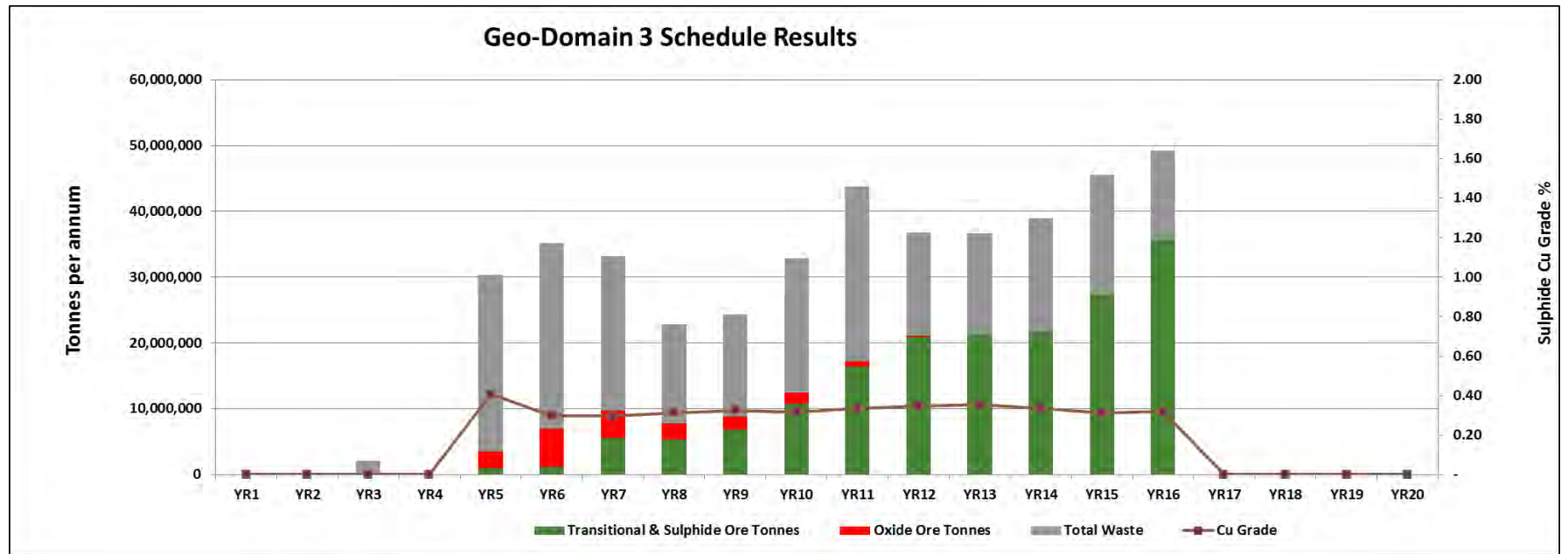
	YR1	YR2	YR3	YR4	YR5	YR6	YR7	YR8	YR9	YR10	YR11	YR12	YR13	YR14	YR15	YR16	YR17	YR18	
Transitional & Sulphide Ore Tonnes	0	0	13,655	0	0	0	0	0	0	0	0	0	0	0	0	0	171,498	15,631,879	27,282,763
Cu Grade	-	-	0.2526	-	-	-	-	-	-	-	-	-	-	-	-	-	0.2503	0.3516	0.3454
Mo Grade	-	-	0.0182	-	-	-	-	-	-	-	-	-	-	-	-	-	0.0239	0.0072	0.0086
Au Grade	-	-	0.1534	-	-	-	-	-	-	-	-	-	-	-	-	-	0.1609	0.0567	0.0631
Oxide Ore Tonnes	0	0	38,275	0	0	0	0	0	0	0	0	0	0	0	0	0	334,875	3,381,437	1,407,922
Cu Grade	-	-	0.22	-	-	-	-	-	-	-	-	-	-	-	-	-	0.26	0.29	0.25
Total Ore	0	0	51,930	0	0	0	0	0	0	0	0	0	0	0	0	0	506,373	19,013,316	28,690,685
	-	-	0.23	-	-	-	-	-	-	-	-	-	-	-	-	-	0.26	0.34	0.34
Total Waste	0	0	1,883,248	0	15,242,073	4,106,910	2,852,435	1,320,270	1,300,201	1,384,636	878,708	767,470	195,414	0	0	0	30,135,228	60,986,684	25,664,111
Total Mined	0	0	1,935,178	0	15,242,073	4,106,910	2,852,435	1,320,270	1,300,201	1,384,636	878,708	767,470	195,414	0	0	0	30,641,601	80,000,000	54,354,796



**Figure 16-36: Dimbi (Geo-Domain 2) Production Schedule (Year 1 = 2020)**

**Table 16-16: Imbruminda (Geo-Domain 3) Production Schedule (Year 1 = 2020)**

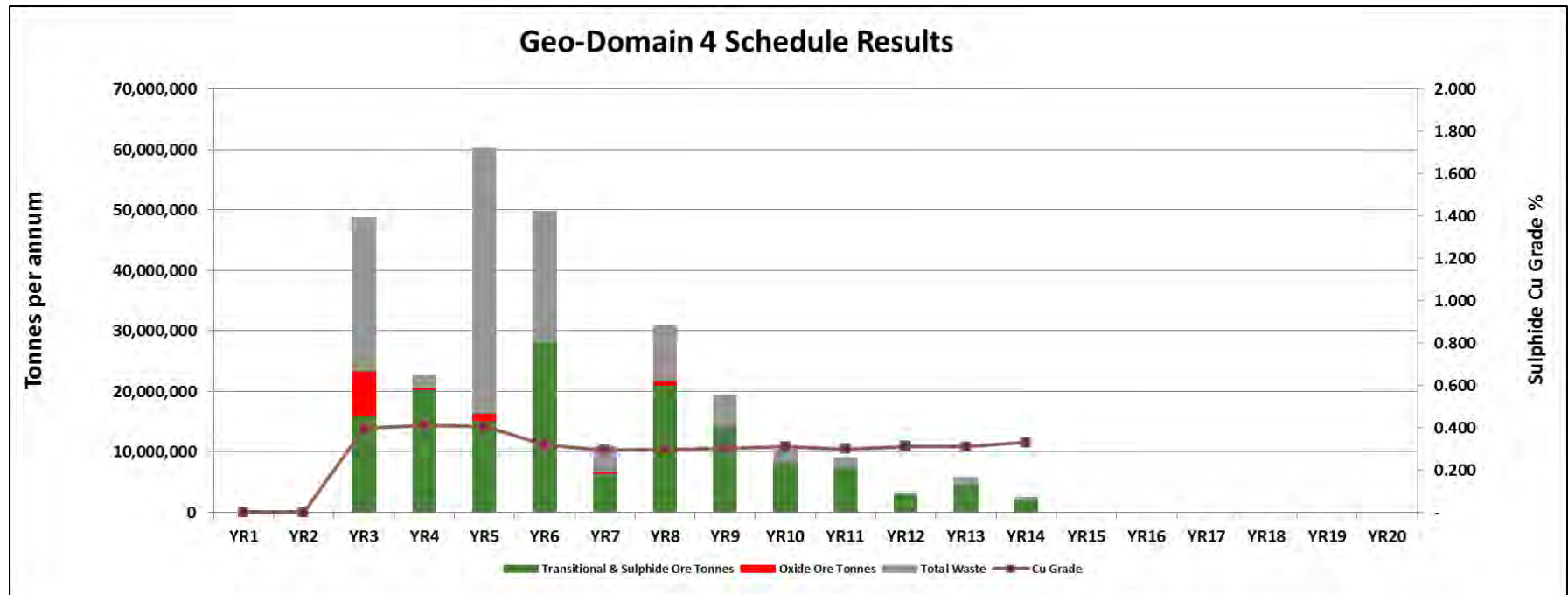
	YR1	YR2	YR3	YR4	YR5	YR6	YR7	YR8	YR9	YR10	YR11	YR12	YR13	YR14	YR15	YR16	YR17	YR18
Transitional & Sulphide Ore Tonnes	0	0	0	0	988,337	1,185,276	5,626,132	5,284,238	6,862,506	10,717,538	16,410,421	20,890,574	21,344,775	21,796,852	27,356,882	35,586,094	0	0
Cu Grade	-	-	-	-	0.41	0.30	0.30	0.31	0.32	0.33	0.33	0.35	0.35	0.33	0.31	0.32	-	-
Mo Grade	-	-	-	-	0.0132	0.0036	0.0064	0.0063	0.0084	0.0090	0.0099	0.0087	0.0093	0.0078	0.0071	0.0089	-	-
Au Grade	-	-	-	-	0.3037	0.0980	0.0709	0.0865	0.1058	0.1031	0.0985	0.0990	0.1007	0.0901	0.0805	0.0686	-	-
Oxide Ore Tonnes	0	0	0	0	2,506,199	5,734,532	4,055,623	2,417,180	1,876,602	1,764,588	735,650	176,181	0	0	0	0	0	0
Cu Grade	-	-	-	-	0.2843	0.2698	0.3097	0.2884	0.2840	0.2970	0.3053	0.3118	-	-	-	-	-	-
Total Ore	0	0	0	0	3,494,536	6,919,808	9,681,755	7,701,418	8,739,108	12,482,126	17,146,071	21,066,755	21,344,775	21,796,852	27,356,882	35,586,094	0	0
	-	-	-	-	0.32	0.27	0.30	0.31	0.32	0.31	0.33	0.35	0.35	0.33	0.31	0.32	-	-
Total Waste	0	0	2,166,137	0	26,826,780	28,192,654	23,524,486	15,187,335	15,596,333	20,434,277	26,602,654	15,716,029	15,295,707	17,187,213	18,187,198	13,603,332	0	0
Total Mined	0	0	2,166,137	0	30,321,316	35,112,462	33,206,241	22,888,753	24,335,441	32,916,403	43,748,725	36,782,784	36,640,482	38,984,065	45,544,080	49,189,426	0	0



**Figure 16-37: Imbruminda (Geo-Domain 3) Production Schedule (Year 1 = 2020)**

**Table 16-17: Gremi (Geo-Domain 4) Production Schedule (Year 1 = 2020)**

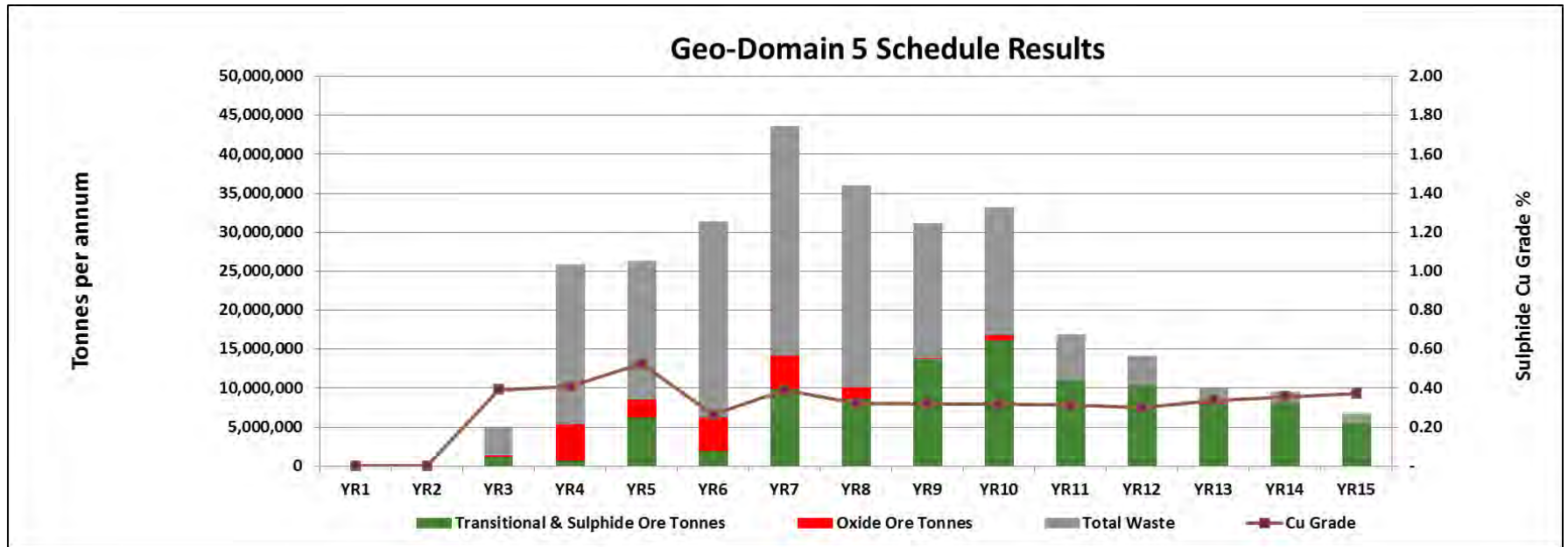
	YR1	YR2	YR3	YR4	YR5	YR6	YR7	YR8	YR9	YR10	YR11	YR12	YR13	YR14	YR15	YR16	YR17	YR18
Transitional & Sulphide Ore Tonnes	0	0	15,954,373	20,245,106	15,088,090	28,017,734	6,326,789	20,964,869	14,078,727	8,113,589	7,377,076	2,816,214	4,604,607	1,960,342	0	0	0	0
Cu Grade	-	-	0.397	0.412	0.404	0.318	0.295	0.296	0.302	0.310	0.300	0.310	0.309	0.330	-	-	-	-
Mo Grade	-	-	0.013	0.019	0.015	0.011	0.010	0.011	0.011	0.011	0.010	0.008	0.008	0.005	-	-	-	-
Au Grade	-	-	0.089	0.089	0.084	0.063	0.054	0.054	0.050	0.049	0.044	0.038	0.031	0.032	-	-	-	-
Oxide Ore Tonnes	0	0	7,244,861	253,763	1,114,358	0	260,099	758,892	63,070	0	0	0	0	0	0	0	0	0
Cu Grade	-	-	0.3851	0.3987	0.3525	-	0.3275	0.2497	0.2087	-	-	-	-	-	-	-	-	-
Total Ore	0	0	23,199,234	20,498,869	16,202,448	28,017,734	6,586,888	21,723,761	14,141,797	8,113,589	7,377,076	2,816,214	4,604,607	1,960,342	0	0	0	0
	-	-	0.39	0.41	0.40	0.32	0.30	0.29	0.30	0.31	0.30	0.31	0.31	0.33	-	-	-	-
Total Waste	0	0	25,657,694	2,111,546	44,202,317	21,877,540	4,340,571	9,235,484	5,309,477	2,278,394	1,762,691	524,250	1,250,545	577,033	0	0	0	0
Total Mined	0	0	48,856,928	22,610,415	60,404,765	49,895,274	10,927,459	30,959,245	19,451,274	10,391,983	9,139,767	3,340,464	5,855,152	2,537,375	0	0	0	0



**Figure 16-38: Gremi (Geo-Domain 4) Production Schedule (Year 1 = 2020)**

**Table 16-18: Omora (Geo-Domain 5) Production Schedule (Year 1 = 2020)**

	YR1	YR2	YR3	YR4	YR5	YR6	YR7	YR8	YR9	YR10	YR11	YR12	YR13	YR14	YR15	YR16	YR17	YR18
Transitional & Sulphide Ore Tonnes	0	0	1,108,489	655,122	6,228,892	1,900,600	9,904,843	8,610,324	13,746,114	16,132,019	10,989,604	10,299,693	7,996,335	8,065,808	5,478,575	0	0	0
Cu Grade	-	-	0.39	0.41	0.53	0.26	0.39	0.32	0.32	0.32	0.31	0.30	0.34	0.35	0.37			
Mo Grade	-	-	-	0.00	0.04	0.01	0.01	0.01	0.01	0.01	0.01	0.01	0.02	0.02	0.02			
Au Grade	-	-	-	0.01	0.01	0.01	0.04	0.04	0.04	0.04	0.05	0.04	0.06	0.06	0.06			
Oxide Ore Tonnes	0	0	326,748	4,670,305	2,342,632	4,402,076	4,218,211	1,474,055	82,756	604,446	184	0	64,986	0	0	0	0	0
Cu Grade	-	-	0.25	0.48	0.37	0.37	0.40	0.29	0.28	0.25	0.22	-	0.15	-	-	-	-	-
Total Ore	0	0	1,435,237	5,325,427	8,571,524	6,302,676	14,123,054	10,084,379	13,828,870	16,736,465	10,989,788	10,299,693	8,061,321	8,065,808	5,478,575	0	0	0
	-	-	0.36	0.47	0.48	0.34	0.39	0.32	0.32	0.32	0.31	0.30	0.34	0.35	0.37	-	-	-
Total Waste	0	0	3,444,045	20,501,717	17,663,586	25,049,378	29,474,585	25,931,649	17,379,580	16,446,130	5,896,242	3,919,989	1,970,819	1,437,457	1,282,975			
Total Mined	0	0	4,879,282	25,827,144	26,235,110	31,352,054	43,597,639	36,016,028	31,208,450	33,182,595	16,886,030	14,219,682	10,032,140	9,503,265	6,761,550	0	0	0



**Figure 16-39: Omora (Geo-Domain 5) Production Schedule (Year 1 = 2020)**





## 16.4 Mine Operations

### 16.4.1 Mine Calendar and Operating Hours

#### 16.4.1.1 Working Calendar

The working calendar of the Yandera mining operation is illustrated in Table 16-19. The mine will operate 360 days per annum based on the factors listed below. An allowance of 5 days per annum was made for a combination of rainfall and fog based on data from PNG operations and the assumption that during steady state mining road construction will be complete and water management systems will be in place to enable production rates to be maintained during heavy rainfall events.

- The mine will operate on a continuous basis (i.e. 24 hours per day and 7 days a week).
- The mine will operate two 12-hour shifts per day.
- None of the PNG public holidays will be observed.
- Five days per annum will be lost due to rain and fog.

**Table 16-19: Working Calendar**

Description	Input	Output
Calendar days per annum	365	
Public holidays observed per annum	0	
Days lost per annum due to rainfall and fog	5	
Working days per annum		360
Working shifts per annum (2 shifts per day)		720
Calendar hours per annum (24 hours x calendar days per annum)		8,760
Working hours per annum ( 24 hours x working days per annum)		8,643

#### 16.4.1.2 Productive Time

Productive time is defined as the time that is available per shift to do productive activities such as drilling, loading and hauling. It is calculated by subtracting the time that is spent undertaking non-productive activities such as safety meetings and equipment pre-use inspections from the total time available per shift. In the context of this study, it also includes allowances for fatigue and lunch breaks, which are necessary to ensure compliance with PNG’s Section 49 of the Employment Act of 1978.

**Table 16-20: Productive and Non-Productive Time**

Description	Units	
Travelling to the face	min	15
Safety meeting	min	15
Equipment pre-use inspections	min	15
Lunch break	min	60
Fatigue breaks (2 x 15minute breaks)	min	30



Description	Units	
Refuelling or bench-to-bench movements	min	15
Travelling from the face	min	15
Total non-productive time per shift	hours	2.8
Total non-productive time per day (2 shifts per day)	hours	5.5
Total non-productive time per annum (360 days per annum)	hours	1,981
<b>Productive time per shift (total hours per shift – non-productive time per shift)</b>	<b>hours</b>	<b>9.3</b>
<b>Productive time per day (2 shifts per day)</b>	<b>hours</b>	<b>18.5</b>
<b>Productive time per annum (360 days per annum)</b>	<b>hours</b>	<b>6,662</b>

### 16.4.1.3 Mechanical Availability

Downtime comprises two components namely planned and unplanned maintenance. Planned maintenance is undertaken at service intervals that are recommended by Original Equipment Manufacturers (OEMs) and it was estimated to be 534 hours per annum based on the data provided by OEMs. Unplanned maintenance is undertaken when equipment breaks down. The occurrence of breakdowns depends on a variety of site-specific conditions including haul road conditions, operator behaviour and the quality of servicing done on the equipment. An allowance for unplanned maintenance was estimated based on operational experience to be 5 % of the available productive time per annum, which was calculated by subtracting planned maintenance from the productive time in Table 16-20 and multiplying the result with 5 %. This is equivalent to 306 hours per annum.

The total time that equipment is mechanically available was estimated to be 7,920 hours per annum by subtracting the total downtime (840 hours per annum) from calendar hours per annum. The mechanical availability was then calculated as follows:

$$\text{Mechanical Availability} = \frac{\text{Total hours that equipment is mechanically available per annum}}{\text{Calendar hours per annum}}$$

$$\text{Mechanical Availability} = \frac{7,920 \text{ hours/annum}}{8,760 \text{ hours/annum}}$$

$$\text{Mechanical Availability} = 0.9041$$

$$\text{Mechanical Availability} = 90 \%$$

### 16.4.1.4 Available Time

Available time, which is the net time that is available to operate equipment after the time that is lost due to maintenance, breakdowns and non-productive activities has been taken into consideration, was estimated to be 5,822 hours per annum as illustrated in Table 16-21.



**Table 16-21: Available Time**

Description	Units	
Working hours per annum	hours	8,643
Downtime per annum due to maintenance	hours	840
Non-productive time per annum	hours	1,981
<b>Available hours per annum</b>		<b>5,822</b>

### 16.4.1.5 Mine Roster Cycle

It is recommended that the mine be operated on a four-day on and four-days off roster cycle as illustrated on Figure 16-40. This roster cycle will require four crews per shift to ensure continuous operation of the mine.

		Day	Day Shift	Night shift	Off Work	Off Work
<b>WEEK 1</b>	Monday	1	Crew 1	Crew 3	Crew 2	Crew 4
	Tuesday	2	Crew 1	Crew 3	Crew 2	Crew 4
	Wednesday	3	Crew 1	Crew 3	Crew 2	Crew 4
	Thursday	4	Crew 1	Crew 3	Crew 2	Crew 4
	Friday	5	Crew 2	Crew 4	Crew 1	Crew 3
	Saturday	6	Crew 2	Crew 4	Crew 1	Crew 3
	Sunday	7	Crew 2	Crew 4	Crew 1	Crew 3
<b>WEEK 2</b>	Monday	8	Crew 2	Crew 4	Crew 1	Crew 3
	Tuesday	9	Crew 3	Crew 1	Crew 2	Crew 4
	Wednesday	10	Crew 3	Crew 1	Crew 2	Crew 4
	Thursday	11	Crew 3	Crew 1	Crew 2	Crew 4
	Friday	12	Crew 3	Crew 1	Crew 2	Crew 4
	Saturday	13	Crew 4	Crew 2	Crew 1	Crew 3
	Sunday	14	Crew 4	Crew 2	Crew 1	Crew 3
<b>WEEK 3</b>	Monday	15	Crew 4	Crew 2	Crew 1	Crew 3
	Tuesday	16	Crew 4	Crew 2	Crew 1	Crew 3
	Wednesday	17	Crew 1	Crew 3	Crew 2	Crew 4
	Thursday	18	Crew 1	Crew 3	Crew 2	Crew 4
	Friday	19	Crew 1	Crew 3	Crew 2	Crew 4
	Saturday	20	Crew 1	Crew 3	Crew 2	Crew 4
	Sunday	21	Crew 2	Crew 4	Crew 1	Crew 3
<b>WEEK 4</b>	Monday	22	Crew 2	Crew 4	Crew 1	Crew 3
	Tuesday	23	Crew 2	Crew 4	Crew 1	Crew 3
	Wednesday	24	Crew 2	Crew 4	Crew 1	Crew 3
	Thursday	25	Crew 3	Crew 1	Crew 2	Crew 4
	Friday	26	Crew 3	Crew 1	Crew 2	Crew 4
	Saturday	27	Crew 3	Crew 1	Crew 2	Crew 4
	Sunday	28	Crew 3	Crew 1	Crew 2	Crew 4
<b>WEEK 5</b>	Monday	29	Crew 4	Crew 2	Crew 1	Crew 3
	Tuesday	30	Crew 4	Crew 2	Crew 1	Crew 3
	Wednesday	31	Crew 4	Crew 2	Crew 1	Crew 3
	Thursday	32	Crew 4	Crew 2	Crew 1	Crew 3
	Friday	33	Crew 1	Crew 3	Crew 4	Crew 2
	Saturday	34	Crew 1	Crew 3	Crew 4	Crew 2
	Sunday	35	Crew 1	Crew 3	Crew 4	Crew 2

**Figure 16-40: Mine Roster Cycle**



## 16.4.2 Mining Equipment

### 16.4.2.1 Introduction

The number of items of equipment was calculated based on the production requirements of an initial production schedule as illustrated in Figure 16-41, with the mine producing material exceeding 100million tonnes per annum between the fifth and seventh year and it is expected that equipment requirements will be at their peak during this period. The updated production scheduling scenarios does not have a material effect on the equipment requirements.

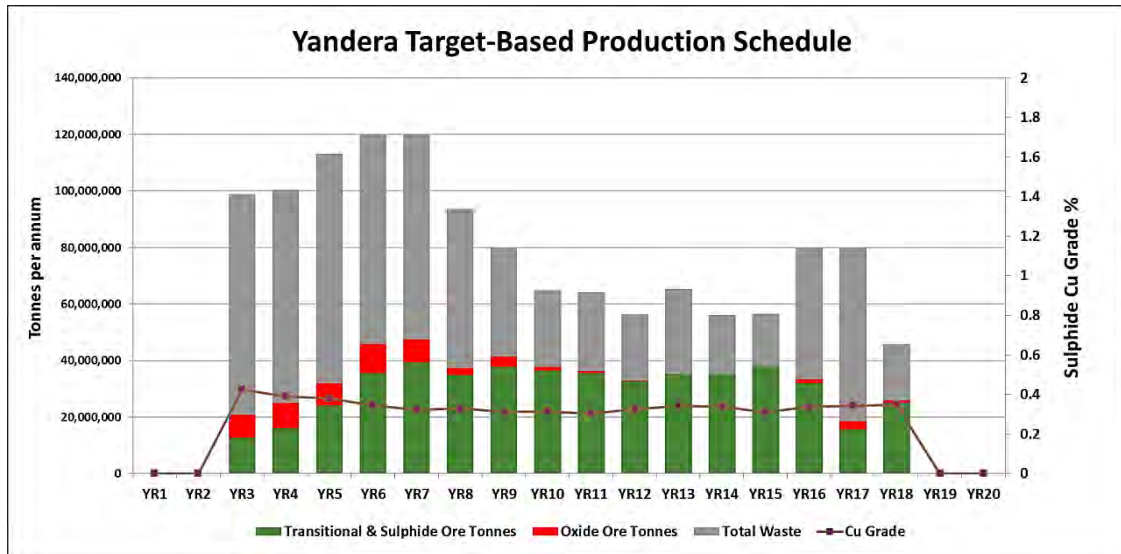


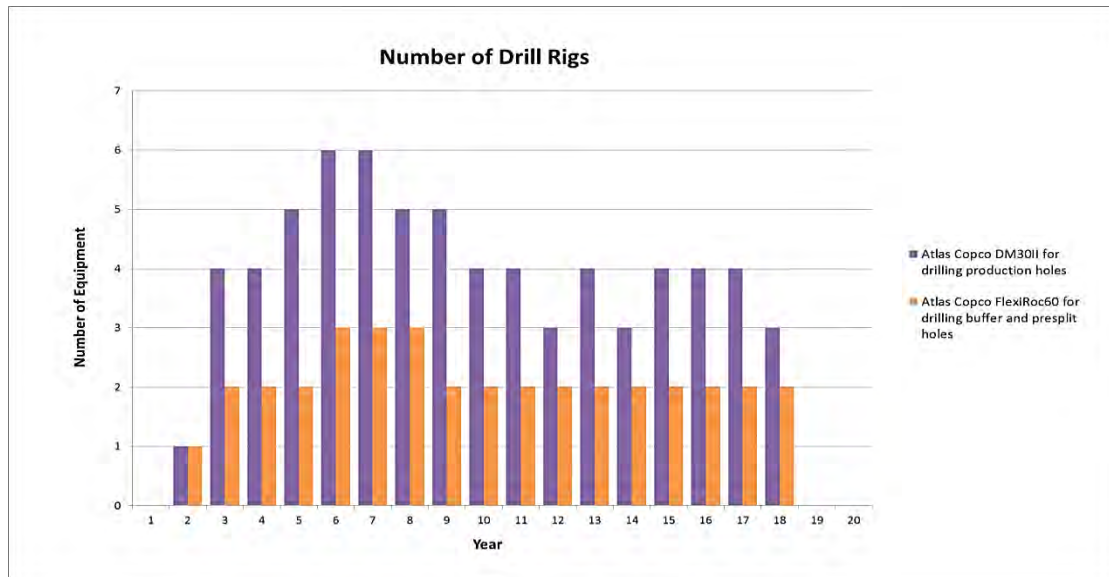
Figure 16-41: Production Requirements of the Mine (Year 1 = 2020)

### 16.4.2.2 Drilling Equipment

Atlas Copco DM30II class drill rigs were considered for drilling production holes and Atlas Copco FlexiRoc60 class drill rigs are considered for drilling presplit and buffer holes. The maximum theoretical production rates of the drill rigs were calculated based on the design parameters provided in Table 16-9 and the penetration rates provided by Atlas Copco. The penetration rates were determined based on the geotechnical properties of the rockmass and are inclusive of the time that will be spent moving the drill rig from a drilled hole to the position of the next hole, coupling and decoupling of drill steels and withdrawal of drill steels from a drilled hole. The production rates of the drill rigs are illustrated in Table 16-22 and the number of drill rigs required over the life of mine is illustrated in Table 16-22.

Table 16-22: Maximum Theoretical Production Rates of Drilling Equipment

Description	Units	Fresh Ore	Oxidized Ore	Fresh waste	Oxidized Waste
<b>Production drilling</b>					
Effective penetration rate	m/hour	42.8	91.1	24.5	88.2
Production rate of drill rig	m/annum	249,411	530,180	142,432	513,764
<b>Buffer and presplit drilling</b>					
Effective penetration rate	m/hour	52.9	92.6	28.7	91.7
Production rate of drill rig	m/annum	307,827	539,179	167,237	533,806



**Figure 16-42: Number of Drill Rigs over the Life of Mine (Year 1 = 2020)**

### 16.4.2.3 Loading and Hauling Equipment

Trade-off studies were conducted to select the types of load and haul equipment required at the mine. Rigid-body dump trucks were selected as primary hauling equipment due to their high payload capacity and their ability to haul material over long distances. Electric rope shovels were selected as primary loading equipment and wheel loaders were selected as secondary loading equipment to provide flexibility and assist with activities including working between multiple working faces, stockpiling and blending of ore to maintain the required grade of the RoM.

An equipment size matching exercise was conducted using dump trucks and shovels of different sizes and payload capacities. Loading and hauling cycle times and production rates were calculated for each combination of equipment. The calculations were done in line with the mine calendar and available hours calculated and were used to estimate the number of equipment required to meet production targets of the mine. A high-level cost analysis was then completed on each combination of equipment using the budget prices and life cycle costs provided by OEMs.

Considering the potential negative effect of congestion on the overall efficiency of the mining operation and the results of the cost analysis, a combination of Komatsu P&H4100C class electric rope shovels and Belaz 75602 class electric dump trucks is selected for the mine. The capacities of the recommended equipment are illustrated in Table 16-23. The mining shovel is capable of fully loading the recommended dump truck with four passes.

**Table 16-23: Capacity of Load and Haul Equipment**

Description	Units	Komatsu P&H 4100C Electric Shovel	Belaz 75602 Electric Dump Truck
Volume	m <sup>3</sup>	51	218
Payload capacity	tonnes	81.6	360

A combination of Komatsu P&H4100C electric rope shovels and Belaz 75602 electric dump trucks is recommended for the mine. The number of items of equipment required to meet production targets over the LoM is illustrated in Figure 16-43.

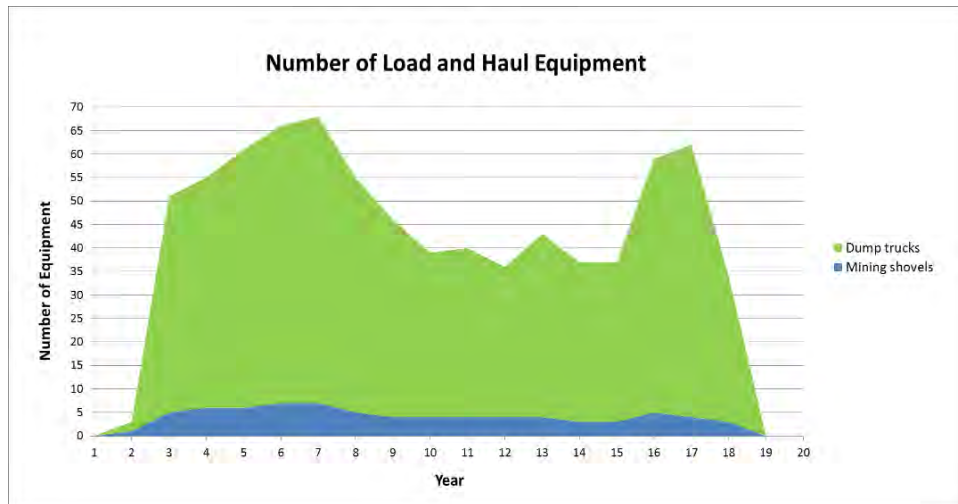


Figure 16-43: Number of Load and Haul Equipment over the Life of Mine (Year 1 = 2020)

### 16.4.2.4 Ancillary Equipment

Ancillary equipment will be required to support the mine. The application of each piece of equipment is summarized in Table 16-24 and the number of items of equipment required over the LoM is illustrated in Table 16-25. The number of items of equipment required was estimated based on previous and similarly-sized projects completed by Worley Parsons and recommendations by OEMs.

Table 16-24: Application of Ancillary Equipment

Equipment	Typical model	Application
Hydraulic excavator	CAT 390F	Road Construction
ADTs	Bell B40E	Road Construction
Wheel dozer	CAT 854K	Cleaning of loading areas
Track dozer	D11T	Levelling of spoil piles
Wheel loader (production)	Komatsu L2350	Additional wheel loader required to ensure continued production in the case of a shovel failure
Wheel loader (stockpiling)	CAT 993K	Stockpile and emergency loading
Soil compactor	CAT CS78B	RoM stockpile
Fuel tanker	CAT 777G	Refuelling
Water tanker	CAT 777G	Dust control and road maintenance
Motor grader	CAT 16M	Road maintenance
Skid steer	CAT 246D	General purpose around the tip
TLB (Backhoe loader)	CAT 432F2	General purpose on site
Tyre handler	CAT 980H	Tyre handling in the workshop
Service truck	CAT 777G	Breakdowns and maintenance
Tool carrier	CAT IT 938K	Tool handler in the workshop
Low bed	CAT 776D	Transportation of crawler-mounted equipment
Portable light tower	Atlas Copco LED light tower	





**Table 16-25: Ancillary Equipment (Year 1 = 2020)**

Equipment	Y1	Y2	Y3	Y4	Y5	Y6	Y7	Y8	Y9	Y10	Y11	Y12	Y13	Y14	Y15	Y16	Y17	Y18	Y19	Y20
Hydraulic excavator	15	15	15	15	15	15	15	15	10	10	10	10	10	10	10	10	10	10	0	0
ADTs	45	45	45	45	45	45	45	45	30	30	30	30	30	30	30	30	30	30	0	0
Wheel dozer	1	1	3	3	3	4	4	3	2	2	2	2	2	2	2	3	2	2	0	0
Track dozer	1	1	5	6	6	7	7	5	4	4	4	4	4	3	3	5	4	3	0	0
Wheel loader (production)	1	1	1	1	1	1	1	1	1	1	1	1	1	1	1	1	1	1	0	0
Wheel loader (stockpiling)	0	1	1	1	2	2	2	2	2	2	2	2	2	2	2	2	2	2	0	0
Soil compactor	1	1	2	2	3	4	4	3	2	2	2	2	2	2	2	2	2	2	0	0
Fuel tanker	1	1	2	2	2	2	2	2	2	2	2	2	2	2	2	2	2	2	0	0
Water tanker	1	2	3	3	3	3	3	3	3	3	3	3	3	3	3	3	3	3	0	0
Motor grader	3	3	3	3	3	3	3	3	3	3	3	3	3	3	3	3	3	3	0	0
Skid steer	1	1	1	1	1	1	1	1	1	1	1	1	1	1	1	1	1	1	0	0
TLB (Backhoe loader)	2	2	2	2	2	2	2	2	2	2	2	2	2	2	2	2	2	2	0	0
Tyre handler	1	1	2	2	2	2	2	2	2	2	2	2	2	2	2	2	2	2	0	0
Service truck	1	1	2	2	2	2	2	2	2	2	2	2	2	2	2	2	2	2	0	0
Tool carrier	1	1	1	1	1	1	1	1	1	1	1	1	1	1	1	1	1	1	0	0
Low bed	1	1	1	1	1	1	1	1	1	1	1	1	1	1	1	1	1	1	0	0
Portable light tower	15	15	15	15	15	15	15	15	15	15	15	15	15	15	15	15	15	15	0	0



### 16.4.3 Contractor Mining

Contractor mining was considered for the Yandera Project to add further value and reduce risk. Details on the costs associated with using contractors are provided.

Contractor mining offers many benefits and contractors may be used in a variety of scenarios including the following:

- Mining operations that have variable production or stripping rates, where the required equipment will vary on a regular basis;
- Projects where contractors offer greater expertise and experience than the owners team or where the owner does not have the required skills and experience in-house;
- Projects that do not have a long life span and the services of employees will only be required for a short duration, or when projects do not require full time employment;
- Projects where the contractors can offer specialized equipment and techniques that the owner cannot provide.
- Projects where specialized skills may be required, such as shaft sinking, high speed decline development or open pit mining over previously mined underground excavations;
- In cases where the owner does not have access to the capital required to purchase a mining production fleet and/or do not have sufficient lead time available for new equipment to arrive at the mine site before first production is required.



## 17 Recovery Methods

---

The ore body at Yandera has been the subject of a number of historical studies, the most recent of which was done in 2013 by Era. Review of historical test work interpretation and flowsheet selection satisfied the authors that the flowsheet is appropriate for treatment of the ore body and the historically selected flowsheet was adopted. Test work interpretation and flowsheet selection is discussed in Section 13.

The proposed treatment method is comminution followed by flotation to produce a saleable concentrate. This is a commonly used and accepted treatment route for copper porphyry ores across the world. The ore at Yandera upgrades readily by flotation to produce a high-grade copper concentrate when processing sulphide ore and a lower grade concentrate when processing oxide ore. An option to produce molybdenum disulphide concentrate is also included in the flowsheet.

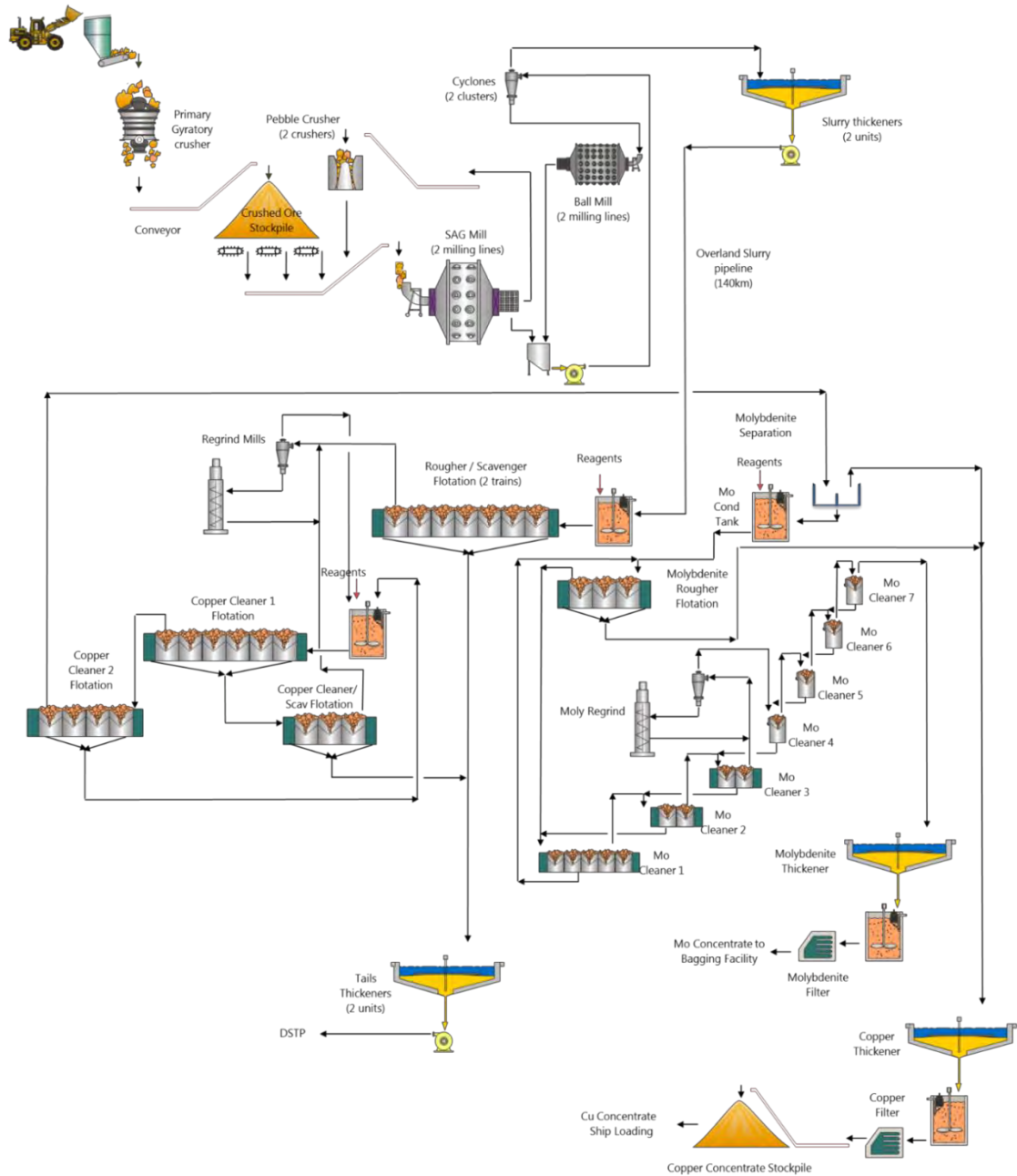
### 17.1 Proposed Processing Methods

The selected flowsheet comprises milling and flotation to produce two concentrate streams, i.e. a copper concentrate and a molybdenum disulphide concentrate.

The major unit operations consist of:

- Crushing.
- Two stage milling (SAG and Ball milling) incorporating pebble crushing.
- Slurry dewatering and overland transfer by pipeline.
- Bulk rougher and scavenger flotation.
- Copper concentrate regrind ahead of two stage cleaning and a cleaner scavenger circuit.
- Molybdenite rougher circuit.
- Seven stage molybdenum disulphide cleaner circuit incorporating concentrate regrind.
- Concentrate dewatering and filtration/drying.
- Tailings dewatering and disposal by DSTP (Deep Sea Tailings Placement).

A schematic of the processing flowsheet is shown in Figure 17-1



**Figure 17-1: Process Flow Schematic**

### 17.1.1 Process Description

RoM ore is crushed in a single stage gyrotory crusher and conveyed to the coarse ore stockpile. Ore from the stockpile is withdrawn by a series of vibrating feeders onto the mill feed conveyor. The grinding circuit consists of a SAG milling, ball milling and pebble crushing (SABC) circuit. The ball mill operates in closed circuit with a classification cyclone cluster. Cyclone overflow is dewatered in a thickener ahead of an overland slurry transfer pipeline.



Slurry is received into a conditioning tank ahead of the bulk rougher/scavenger flotation circuit. Re-grinding and two stage cleaning of copper concentrates produces a bulk copper and molybdenite concentrate. Following this, copper and molybdenite separation occurs in a multistage flotation and regrind circuit. Copper concentrates are dewatered by thickening and filtration, and conveyed to a covered stockpile at the wharf for periodic ship bulk loading for export. Molybdenite concentrates are thickened, dried and bagged for shipment. Flotation tailings are thickened and pumped to tanks where these are diluted with seawater prior to discharge to the DSTP subsea pipeline.

### 17.1.2 Technical Benchmarking – Flowsheet

This section reviews other copper mines in the region, which are either operating or under development, to assess flowsheet selection. Figure 17-2 and Figure 17-3 shows the geological terranes of PNG, as well as the location of major mineral projects and predominant metals targeted.

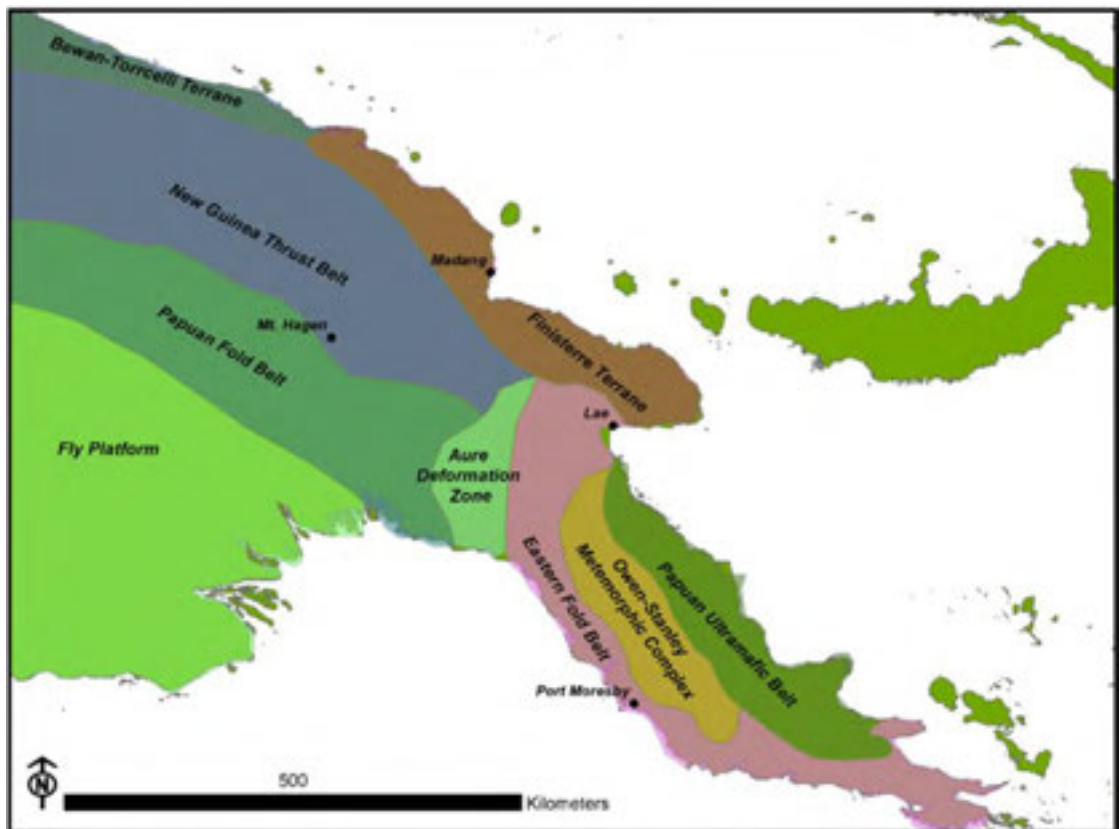


Figure 17-2: Geologic Terranes of New Guinea



Figure 17-3: Major Mineral Projects in PNG<sup>7</sup>

It can be seen from Figure 17-3 that copper projects located in similar geological terranes to Yandera are:

- Ok Tedi
- Frieda River
- Wafi-Golpu
- Grasberg

The flowsheet selected for the Project is similar to the flowsheets selected for each of these operations or projects, with further detail provided below.

### 17.1.2.1 Ok Tedi

Ok Tedi Mining Limited mines and treats a large copper porphyry/skarn ore body at Mt Fubilan in the far north of the Western Province of PNG. The copper concentrator uses a conventional sulphide mineral recovery and concentration process to produce a copper concentrate, which is sold and exported to smelters around the world.

The processing flow sheet comprises the following:

- Primary grinding in a semi-autogenous grinding mill.
- Secondary grinding in ball mills, in closed circuit with hydro cyclones.
- Copper mineral flotation in a conventional roughing/scavenging/cleaning circuit, and includes a regrind circuit.

<sup>7</sup> <http://pngchamberminpet.com.pg/mining-in-png/>





- Iron sulphide mineral flotation, in a conventional roughing/cleaning flotation circuit, for the recovery of a pyrite concentrate from the copper flotation tailings to address environmental constraints.
- Riverine disposal of tailings.
- Storage of the pyrite concentrate in purpose built pits.

The concentrator can treat in excess of 22Mtpa of ore to produce approximately 100,000t of copper and 320,000 ounces of gold. There are approximately 205 staff members in the Concentrator Operations, Process Maintenance, and Process Technical Services departments.<sup>8</sup>

### 17.1.2.2 Frieda River

The development concept for the Frieda river project is described by PanAust in the Frieda River Feasibility Study, which contemplates a project, comprised a large-scale, open pit mining operation feeding ore to a conventional process plant.<sup>9</sup>

A single process plant module is envisaged, having a similar configuration to the Phu Kham concentrator, with a circa 56MW comminution circuit with conventional flotation plant allowing a LoM average throughput rate of 30Mtpa; +/-20% depending on ore hardness<sup>10</sup>. The plant design incorporates a single processing line and includes the following components:

- Gyratory crusher.
- Overland conveyor.
- Coarse ore stockpile.
- SAG and ball mill grinding circuit.
- Flotation circuit including regrind and three stages of cleaning.
- Concentrate dewatering and concentrate load-out facilities<sup>11</sup>.

### 17.1.2.3 Golpu

The Golpu project is a joint venture between Harmony Gold Mining Company Limited and Newcrest Mining Ltd. An FS has been prepared based on processing of ore on site using conventional single stage SAG and ball mill grinding and flotation to produce a copper and gold concentrate.<sup>12</sup>

The flowsheet for the concentrator would comprise:

- a primary crusher,
- SAG mill, ball mill and pebble crushing circuit;

<sup>8</sup> <http://www.oktedi.com/our-operations/concentrator-operations>

<sup>9</sup> <http://www.highlandspacific.com/current-projects/frieda-copper>

<sup>10</sup>

[http://www.panaust.com.au/sites/default/files/presentations/Std\\_investor\\_presentation\\_Sep2014\\_%20with\\_%20Frieda\\_%20River\\_FINALAS\\_X.pdf](http://www.panaust.com.au/sites/default/files/presentations/Std_investor_presentation_Sep2014_%20with_%20Frieda_%20River_FINALAS_X.pdf)

<sup>11</sup> Design of a Large-Scale Concentrator for Treatment of a Copper Skarn Orebody, J Glatthaar, G Lane, M Phillips and T Hayward, Ninth Mill Operators' Conference Fremantle, WA, 19 - 21 March 2007

<sup>12</sup> <https://www.harmony.co.za/investors/news-and-events/presentations-2/presentations-2012/category/7-2012>



- bulk rougher flotation followed by regrinding and three stages of concentrate cleaning;
- concentrate thickening and storage facilities; and
- Concentrate transfer by slurry pipeline to dewatering, storage and ship loading facilities near Lae.<sup>13</sup>

#### 17.1.2.4 Grasberg

There are four concentrators at the Grasberg operation, capable of treating almost 240,000t/d of copper-gold sulphide ore at an average grade of 1.1% Cu, 1.1g/t Au and 2.5g/t Ag.

The two more modern concentrators use SAG mills, a 10.4m diameter unit in #3 drawing 13MW, with two 6.1m ball mills drawing 6.5MW each and an 11.6m diameter SAG mill in #4 drawing 20MW, with four 7.3m ball mills drawing 10MW each. The milling circuits include pebble crushing.

All four concentrators adopted the same flotation circuit configuration: several parallel rougher banks followed by a cleaner circuit that treats reground rougher concentrate. The rougher concentrate is upgraded in primary and secondary cleaning columns with the tails from the latter re-scavenged. Concentrate is thickened and pumped to the filtration plant ahead of shipping for export.<sup>14</sup>

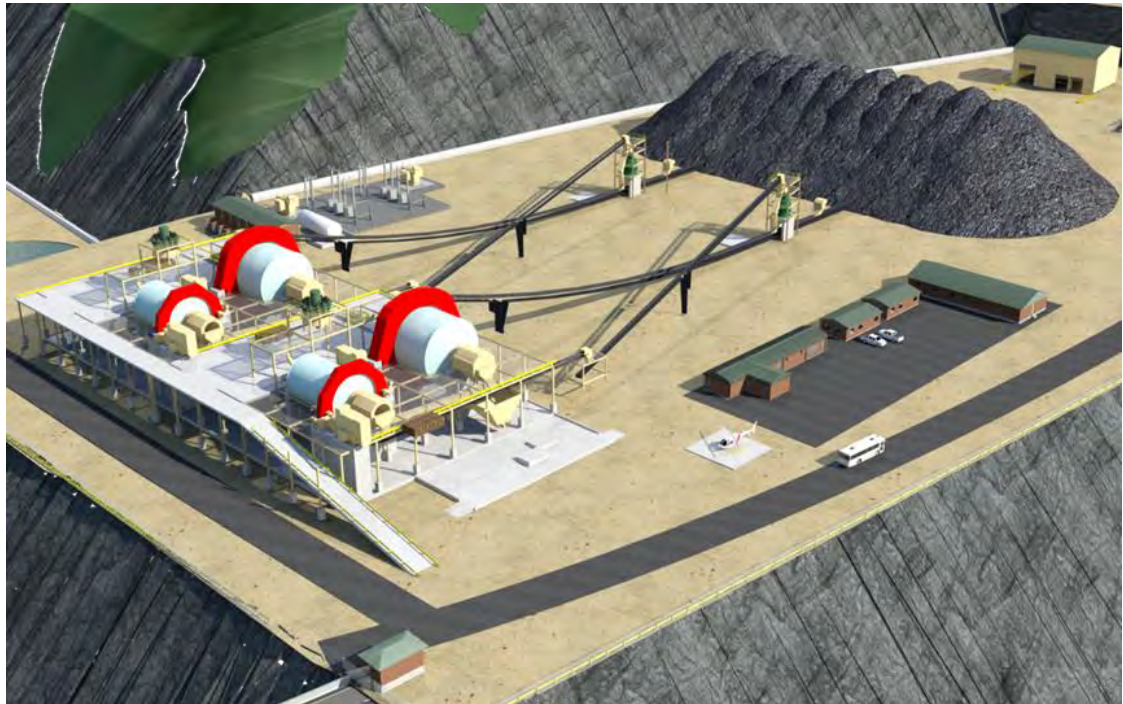
## 17.2 Plant Design

### 17.2.1 Facilities Description

The process plant is designed for a throughput of 30Mtpa. Treatment of ore arising from the Project will be effected in two locations. The comminution circuit is located at the Yandera mine site. Primary crushed ore is treated in two SAG mills operated in parallel open circuit and with scats recycle via a pebble crushing system on each train. SAG mill product is classified and further ground by two parallel ball milling and hydrocyclone circuits operating in closed circuit. The Yandera milling plant is accessible by road from Lae at a distance of approximately 300km.

<sup>13</sup> [http://www.newcrest.com.au/media/resource\\_reserves/2012/August\\_2012\\_Golpu\\_Pre-Feasibility\\_Study\\_and\\_Reserve\\_Announcement.pdf](http://www.newcrest.com.au/media/resource_reserves/2012/August_2012_Golpu_Pre-Feasibility_Study_and_Reserve_Announcement.pdf)

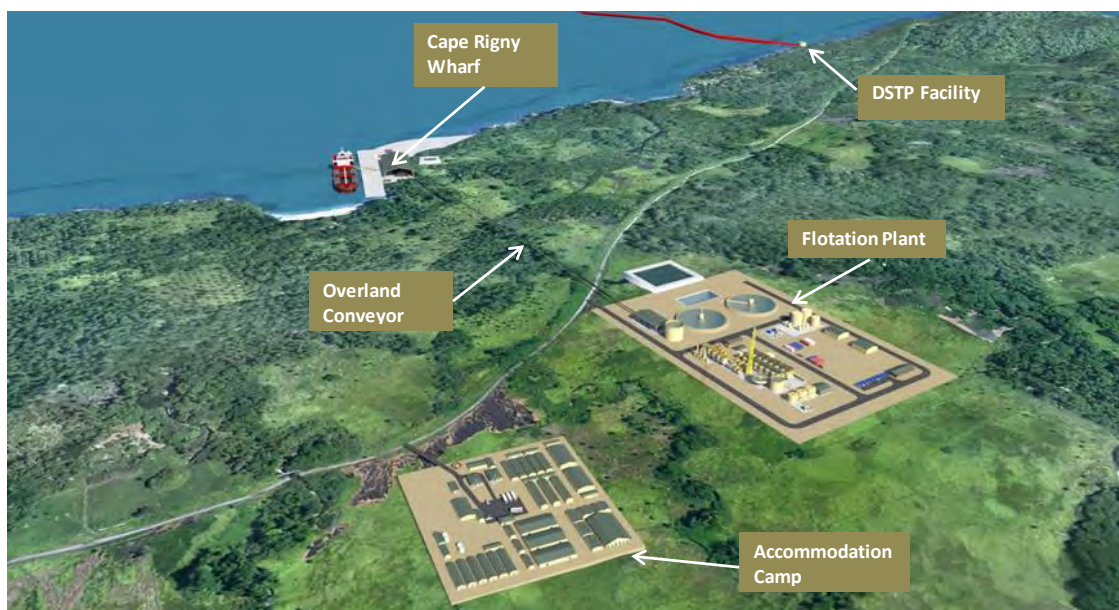
<sup>14</sup> Published in International Mining May 2010, Operation Focus – Indonesia – Grasberg concentrator by John Chadwick



**Figure 17-4: Conceptual View of Mills and Coarse Ore Stockpile**

Whole ore slurry is thickened and transferred by overland pipeline to the coastal facility for concentration by flotation. The coastal facility plant comprises bulk flotation and regrind, Cu cleaning circuit, Mo separation flotation circuit, concentrate and tailings thickening facilities. Historical studies considered alternatives for tailings disposal and DSTP was selected as the preferred option for this study.

The flotation circuit will be located at the coastal facility in close proximity to the DSTP outfall point and concentrate export wharf. The coastal facilities are accessed by barge from Madang, and linked to the milling plant by the 146km long overland slurry pipeline.



**Figure 17-5: Conceptual View of Coastal Facilities at Cape Rigny**



Oxide ore is stockpiled at the Yandera mine site and will be processed subsequent to sulphide ore processing at the end of the LoM.

## 17.2.2 Plant Design Methodology

The approach followed for the PFS plant design is outlined below:

- The process design criteria document was developed with input parameters derived from metallurgical test work interpretation and flotation circuit modelling, vendor advice and the Advisian database.
- The process flowsheets were developed for the entire operation, including mine and plant related infrastructure.
- Mass and water balances were produced.
- Sizing of major mechanical equipment was undertaken, with further detail on selected equipment provided in Section 17.3.
- A mechanical equipment list was produced, including an electrical load list. Data sheets and specifications were developed for major mechanical equipment and schedules were developed for other equipment i.e. agitators, platework, pumps etc.
- Plant layout drawings were developed and general arrangement drawings (plan and elevation views) for the major unit operations.
- Preliminary civil and structural engineering designs were developed based on the general arrangement drawings and vendor information for the major mechanical equipment loads.
- Preliminary pipe routing drawings were produced to support estimation of piping quantities.
- An electrical single line diagram was produced as well as sizing of major electrical equipment.
- A detailed list of the drawings and design documents and bases of design that were produced in support of this study is included in Section 17.6.

## 17.2.3 Plant Related Infrastructure

The Yandera milling plant is co-located in a consolidated precinct with the plant and mine-related support infrastructure. Infrastructure local to the milling plant includes shared offices, assay laboratory, ablutions, canteen facilities as well as stores and LV and plant workshops.

The Yandera precinct includes fuel storage and distribution, potable water treatment and reticulation, fire water storage and reticulation, incoming HV switchyard, MCCs and site power reticulation, emergency generators, sewage and waste collection and treatment, storm water diversion, site drainage and sediment control, site roads, security fencing and access control. Further detail on the local infrastructure is provided in Section 18. The coastal facilities are standalone from the Yandera milling precinct and are equipped with similar local infrastructure.



## 17.2.4 Process Design Criteria

Extracts from the process design criteria summarizing the key performance parameters for the plant are included in the tables below. Concentrate systems are designed on maximum recovery figures.

**Table 17-1: Production Schedules**

Description	Units	Value
<b>Primary Crushing</b>		
Expected overall availability and utilization	%	75
Expected annual operating hours	h/a	6,570
Feed rate	t/h	4,566
<b>Coarse Ore Reclaim, Milling, Thickening, Overland Slurry Transfer, Flotation, Regrind, Thickening and DSTP</b>		
Expected overall availability and utilization	%	91.3
Expected annual operating hours	h/a	8,000
Feed rate	t/h	3,750
<b>Concentrate Filtration</b>		
Expected overall availability and utilization	%	80
Expected annual operating hours	h/a	7,008

**Table 17-2: Ore Head Grades**

Description	Units	Value	
Ore head grades - Oxides, average	Copper, Cu	%	0.330
	Molybdenum, Mo	%	0.010
	Gold, Au	g/t	0.116
Ore head grades - Non-oxides, average	Copper, Cu	%	0.320
	Molybdenum, Mo	%	0.010
	Gold, Au	g/t	0.097

**Table 17-3: Concentrate Production**

Description	Units	Value
<b>Oxides</b>		
<b>Rougher-scavenger bulk flotation concentrate</b>		
Production Rate	% of new feed	5.0
<b>Cu Concentrate Production</b>		
Recovery – Cu	%	58.0 <sup>15</sup>
Grade – Cu	%	20.0
Production Rate	% of new feed	0.96

<sup>15</sup> Initial estimate at beginning of study used for sizing of equipment.





Description	Units	Value
	t/a	286,926
<b>Non-Oxides</b>		
<b>Rougher-scavenger bulk flotation concentrate</b>		
Production Rate	% of new feed	3.5
<b>Cu Concentrate Production</b>		
Recovery - Cu	%	93.0
Grade - Cu	%	28.0
Production Rate	% of new feed	1.06
	t/a	318,957
<b>Mo Concentrate Production</b>		
Recovery - Mo	%	69.0
Grade - Mo	%	47.0
Production Rate	% of new feed	0.014
	t/a	4,272

**Table 17-4: Ore Physical Characteristics**

Description	Units	Design Value (80th %tile)
Moisture	% H2O	10
Ore Specific Gravity	-	2.63
Unconfined Compressive Strength	MPa	66
Bond Crushing Work Index	kWh/t	7.64
Bond Rod Mill Work Index	kWh/t	15.8
Bond Ball Mill Work Index (150 µm target P80 size)	kWh/t	17.2
Bond Abrasion Index	-	0.174
JK Parameters - Drop Weight Index	-	5.54
JK Parameters - Axb	-	46.5

**Table 17-5: Key Sizing Parameters for Unit Operations**

Description	Units	Value
<b>Primary Crushing</b>		
RoM maximum (F100) size	mm	1,200
Product maximum size (P100)	mm	250
Product size (P80)	mm	138
<b>Coarse Ore Storage - Stockpile</b>		
Capacity, live	t	19,589
At mill feed rate	hours	5.2





Description		Units	Value
<b>SAG Milling</b>			
Number of grinding lines		-	2
New feed size	F100 (max. lump size)	mm	250
New feed size	F80	mm	138
Specific power (no factors)		kWh/t	8.48
<b>Pebble Crushing</b>			
Pebble Production Proportion		% new feed	20
Pebble crushing work index		kWh/t	30
Pebble crusher feed size, P100		mm	75
Pebble crusher feed size, P80		mm	39
Pebble crusher product size, P80	Design	mm	11
<b>Ball Milling</b>			
Number of grinding lines		-	2
Final product size	P80	µm	150
Specific power (no factors)		kWh/t	8.22
<b>Hydrocyclone Classification</b>			
Circulating load (cyclone underflow) proportion	Normal	%	250
	Max		350
<b>Mill Discharge Sump</b>			
Residence time		minutes	3
<b>Slurry Thickener</b>			
Thickener U/F slurry density		% solids (w/w)	55.0
Solids loading		t/m <sup>2</sup> h	0.80
<b>Bulk Flotation Dilution and Conditioning - Sulphide (Non-Oxide)</b>			
Tank feed slurry density		% solids (w/w)	36.0
Conditioning time		min	10
<b>Rougher-Scavenger Flotation - Sulphide (Non-Oxide)</b>			
No. of bulk flotation trains		-	2
Slurry pH range		-	7.0 - 8.0
Laboratory residence time		mins	12.0
Laboratory scale-up factor		-	2.5
Design residence time		min	30.0
<b>Bulk Concentrate Re grind</b>			
Bulk concentrate re grind specific energy		kWh/t	21
Product size P80 (nominal)		µm	38



Description	Units	Value
<b>Rougher-Scavenger Flotation - Oxide</b>		
No. of bulk flotation trains	-	2
Slurry pH range	-	7.0 - 8.0
Laboratory residence time	mins	6.0
Laboratory scale-up factor	-	2.5
Design residence time	min	15.0
<b>Copper Cleaning Flotation – Sulphide (Non-Oxide)</b>		
<b>Bulk Concentrate Cleaner Conditioning</b>		
Copper cleaner circuit new feed throughput	t/h	120
Copper cleaner conditioning slurry density	% solids (w/w)	25.0
Conditioning time	min	10
<b>Copper Cleaner 1 Circuit</b>		
No. of Cu Cleaner 1 flotation trains	-	1
Combined Cu Cleaner 1 feed slurry density	% solids (w/w)	18.9
Slurry pH range	-	7.0 - 8.0
Laboratory residence time	mins	8.0
Laboratory scale-up factor	-	2.5
Design residence time	min	20.0
<b>Copper Cleaner 2 Circuit</b>		
No. of Cu Cleaner 2 flotation trains	-	1
Cu Cleaner 2 throughput (Cleaner 1 conc)	t/h	94
Cu Cleaner 2 feed slurry density	% solids (w/w)	19.2
Slurry pH range	-	7.0 - 8.0
Laboratory residence time	mins	8.0
Laboratory scale-up factor	-	2.5
Design residence time	min	20.0
<b>Copper Cleaner-Scavenger Circuit</b>		
No. of Cu Cleaner-scavenger flotation trains	-	1
Cu Cleaner-scavenger concentrate throughput	t/h	80
Cleaner-scavenger feed slurry density	% solids (w/w)	17.7
Slurry pH range	-	7.0 - 8.0
Laboratory residence time	mins	9.0
Laboratory scale-up factor	-	2.5
Design residence time	min	22.5
<b>Copper Concentrate Mo Circuit Conditioning</b>		
Mo flotation circuit new feed throughput	t/h	41



Description	Units	Value
Mo flotation conditioning slurry density	% solids (w/w)	15.0
Conditioning time	min	10
<b>Mo Rougher Flotation Circuit</b>		
No. of Mo rougher flotation trains	-	1
Slurry pH range	-	9.5 - 10.5
Laboratory residence time	mins	15.0
Laboratory scale-up factor	-	2.5
Design residence time	min	37.5
<b>Mo Concentrate Cleaner 1 Circuit</b>		
No. of Mo cleaner 1 flotation trains	-	1
Combined Mo cleaner 1 feed throughput	t/h	10.54
Mo cleaner 1 feed slurry density	% solids (w/w)	14.3
Slurry pH range	-	10
Laboratory residence time	mins	12.0
Laboratory scale-up factor	-	2.5
Design residence time	min	30.0
<b>Mo Concentrate Cleaner 2 Circuit</b>		
No. of Mo cleaner 2 flotation trains	-	1
Combined Mo cleaner 2 feed throughput	t/h	6.18
Mo cleaner 2 feed slurry density	% solids (w/w)	13.2
Slurry pH range	-	10.5
Laboratory residence time	mins	8.0
Laboratory scale-up factor	-	2.5
Design residence time	min	20.0
<b>Mo Concentrate Cleaner 3 Circuit</b>		
No. of Mo cleaner 3 flotation trains	-	1
Combined Mo cleaner 3 feed throughput	t/h	5.34
Mo cleaner 3 feed slurry density	% solids (w/w)	14.0
Slurry pH range	-	10.5
Laboratory residence time	mins	5.0
Laboratory scale-up factor	-	2.5
Design residence time	min	12.5
<b>Mo Regrind Circuit</b>		
Mo Regrind Circuit New Feed ( Mo Cleaner concentrate 3)	t/h	3
Mo Regrind specific energy	kWh/t	32
Product size P80 (nominal)	µm	28



Description	Units	Value
<b>Mo Concentrate Cleaner 4 Circuit</b>		
No. of Mo cleaner 4 flotation trains	-	1
Combined Mo cleaner 4 feed throughput	t/h	3.77
Mo cleaner 4 feed slurry density	% solids (w/w)	15.6
Slurry pH range	-	10.5
Laboratory residence time	mins	5.0
Laboratory scale-up factor	-	2.5
Design residence time	min	12.5
<b>Mo Concentrate Cleaner 5 Circuit</b>		
No. of Mo cleaner 5 flotation trains	-	1
Combined Mo cleaner 5 feed throughput	t/h	1.78
Mo cleaner 5 feed slurry density	% solids (w/w)	13.9
Slurry pH range	-	10.5
Laboratory residence time	mins	5.0
Laboratory scale-up factor	-	2.5
Design residence time	min	12.5
<b>Mo Concentrate Cleaner 6 Circuit</b>		
No. of Mo cleaner 6 flotation trains	-	1
Combined Mo cleaner 6 feed throughput	t/h	1.53
Mo cleaner 6 feed slurry density	% solids (w/w)	13.9
Slurry pH range	-	10.5
Laboratory residence time	mins	5.0
Laboratory scale-up factor	-	2.5
Design residence time	min	12.5
<b>Mo Concentrate Cleaner 7 Circuit</b>		
No. of Mo cleaner 7 flotation trains	-	1
Mo cleaner 7 new feed throughput ( Mo Cleaner 6 Conc)	t/h	1.31
Mo cleaner 7 feed slurry density	% solids (w/w)	15.8
Slurry pH range	-	10.5
Laboratory residence time	mins	5.0
Laboratory scale-up factor	-	2.5
Design residence time	min	12.5
Air holdup allowance	% (v/v)	10
<b>Mo Concentrate Thickener</b>		
Thickener U/F slurry density	% solids (w/w)	65
Solids loading	t/m <sup>2</sup> h	0.25



Description	Units	Value
<b>Mo Concentrate Stock Tank</b>		
Stock tank capacity	h	24
<b>Mo Concentrate Filtration</b>		
Solids filtration rate	kg/m <sup>2</sup> h	400
Nominal moisture content ex-filter	% H <sub>2</sub> O	10.0
<b>Mo Concentrate Drying and Bagging</b>		
Target final moisture content	%	4
Final Mo concentrate packing	-	Bulk Bags
<b>Tails Thickener</b>		
Thickener U/F slurry density	% solids (w/w)	55.0
Solids loading	t/m <sup>2</sup> h	0.80
<b>DSTP Dilution System</b>		
Diluted Tailings	% solids (w/w)	30.0
<b>Copper Concentrate Thickener</b>		
Thickener U/F slurry density	% solids (w/w)	66
Solids loading	t/m <sup>2</sup> h	0.25
<b>Copper Concentrate Stock Tank</b>		
Stock tank capacity	h	12
<b>Copper Concentrate Filtration</b>		
Solids filtration rate	kg/m <sup>2</sup> h	350
Concentrate TML	% H <sub>2</sub> O	10.5
Required moisture content ex-filter	% H <sub>2</sub> O	9.0
<b>Copper Concentrate Stockpile</b>		
Copper concentrate stockpile storage capacity	days	30
<b>Ship Loading</b>		
Bulk Load Parcel Size	t	11,500
Ship Loading Time (bulk)	days	3
Ship Loading Operating Schedule	h/day	10
Shipping Frequency, 1 ship every	days	13

## 17.2.5 Process Sampling, Measurement and Metal Accounting Criteria

### 17.2.5.1 Sampling

Representative sampling within the process plant is essential for metal accounting purposes as well as for process control and plant performance monitoring and optimization.



Automated sampling will be installed on the following streams:

- Flotation feed.
- Rougher tails.
- Cu Cleaner Scavenger tails.
- Mo Ro feed.
- Mo Ro tails.
- Cu 2 conc stream (final Cu conc).
- Cu conc filter feed.
- Mo cleaner 7-conc stream (final Mo Conc).

These samples will be submitted for chemical analysis (typically Cu, Au, S, Fe, MoS<sub>2</sub>, SiO<sub>2</sub>, MgO, As, F and K) and particle size analysis (flotation feed, Cu and Mo regrind circuits feed and product streams)

Manual samples will be taken on a less frequent basis, consisting of various concentrate streams for chemical analysis and water for quality determination.

### 17.2.5.2 In-Stream Analysis

Cu, Mo and deleterious element concentrations of streams within the flotation circuit are continuously monitored to ensure that concentrate grades and recoveries are optimized. The In-stream Analyser (ISA) will be used to control reagent dosing and to monitor flotation cell performance and concentrate composition.

The on-stream monitoring system will be fed via a dedicated sampling system. Streams selected for ISA are:

- Rougher-scavenger flotation feed.
- Rougher-scavenger flotation tail.
- Rougher-scavenger flotation concentrate.
- Copper cleaner-scavenger concentrate.
- Copper cleaner-scavenger tail.
- Copper cleaner 2 concentrate.
- Mo rougher flotation tail.
- Mo final cleaner concentrate.

### 17.2.5.3 Metal Accounting

The metal accounting system provides essential information for financial reporting and diagnostic information for plant operations. The system provides insight to issues such as:

- Production variability.
- Unexplained material losses and gains in Cu and MoS<sub>2</sub>.





- Process inefficiencies.
- Production forecasting requirements.

The metal accounting system comprises the following elements:

- Mass measurement points and equipment.
- Sampling, sample management and analysis.
- Measurement of process inventory, stockpiles and other stocks.
- Data collection and management.
- Mass balancing and reconciliation.
- Metal balance reporting.

## **17.2.6 Process Control**

A centralized control room is envisaged for the Yandera precinct operation, located in the main administration/office building. The coastal facilities will have a similar control room for the flotation plant operation, with a communications link between the two systems.

### **17.2.6.1 Plant Process Control System**

The process plant control system comprises main control room and equipment room at the plant office complex. The equipment room will house the network termination equipment and control system servers. The controllers and field networking equipment will, in general, be co-located in the sub-stations or electrical motor control centres. Field remote IO stations will be installed to interface with the field instrumentation and actuators.

The process plant control room will also fulfil the role of mining control room once production commences.

### **17.2.6.2 Process Control Philosophy**

Automated plant control is provided to minimise the need for continuous operator attention, with provision for manual override and control if required. The control system will provide the necessary control and instrumentation to ensure safety of personnel and protection of equipment, as well as assurance of recovery. Monitoring and control will typically comprise the following components:

- Mass, density and pressure measurement and control, where applicable.
- Airflow control (one per cell).
- Flotation cell and sump level control.
- Extensive data recording, where applicable.

The objective of the control strategy is to use a single control system for the control and monitoring of the concentrator. Drives that form part of a vendor package are integrated into the Process Control System (PCS). Where vendor packages specifically need Process Logic Controllers (PLCs) due to an integrated skid arrangement with off-site testing required (such as flocculant mixing system), efforts are made to standardise such equipment where practically possible.



The general control strategy adopted for the processing plant is as follows:

- Integrated control via the PCS for areas where equipment requires sequencing and process interlocking.
- Hard-wired interlocks for personnel safety (for example trip wires on conveyors).
- Motor controls for starting and stopping of drives at local control stations via the PCS or
- Hard-wired, depending on the drive classification; all drives can be stopped from the local control station at all times; local and remote starting is dependent on the drive class and control mode.
- Monitoring of all relevant operating conditions on the PCS and recording selected information for data logging or trending.
- Trip and alarm inputs to the PCS will be failsafe in operation, i.e. the signal reverts to the de-energized state when a fault occurs.

### 17.2.7 Spillage Management

The generation of spillage in the process plant typically originates from unplanned stops or operator error. Appropriate process control and training will limit the potential for spillage generation. Spillage will be contained by locating process equipment within concrete bunded areas, equipped with spillage pumps. Spillage will be returned to the process to ensure that product is not lost and that the environment is protected.

The milling area is designed with a drive through bund for ease of clean up. Reagent mixing and storage areas will be designed with 110% containment of the largest concentrated storage vessel volume.

Site storm water management is covered in Section 18.5.

### 17.2.8 Mining Ramp-up and Plant Feed Composition

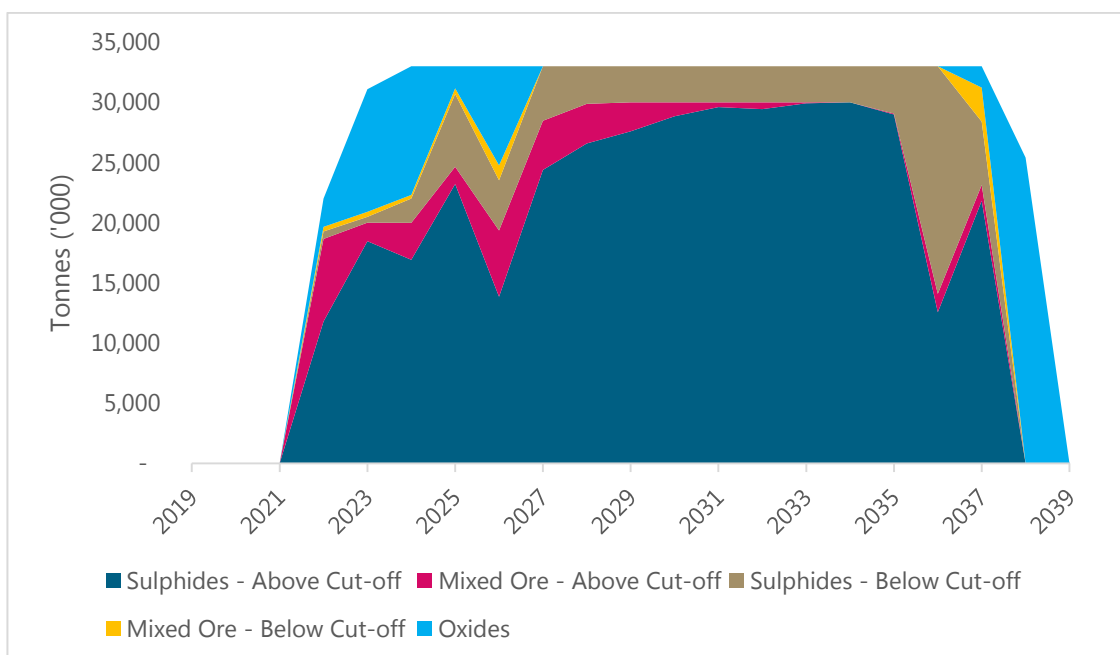


Figure 17-6: Plant Feed Profile



The production profile in Figure 17-6 was generated at the end of the PFS as a deliverable from the mine design and scheduling work stream. Notable observations regarding the production profile are:

- The mine ramps up to full production over a period of three years.
- The feed composition changes over time, and contains a significant portion of oxide material in the early years.
- Production reaches steady state at a maximum plant throughput of 33Mtpa.

The implications of this production profile on the plant design are discussed below:

### **17.2.8.1 Operating Philosophy during Ramp-up**

There may be an opportunity to defer capital in the initial years by installing one milling line or a single SAG mill coupled with two ball mills. The operating strategy during ramp up needs to be defined during the FS. The design should be assessed to determine turndown potential. This could be coupled with a campaign treatment strategy.

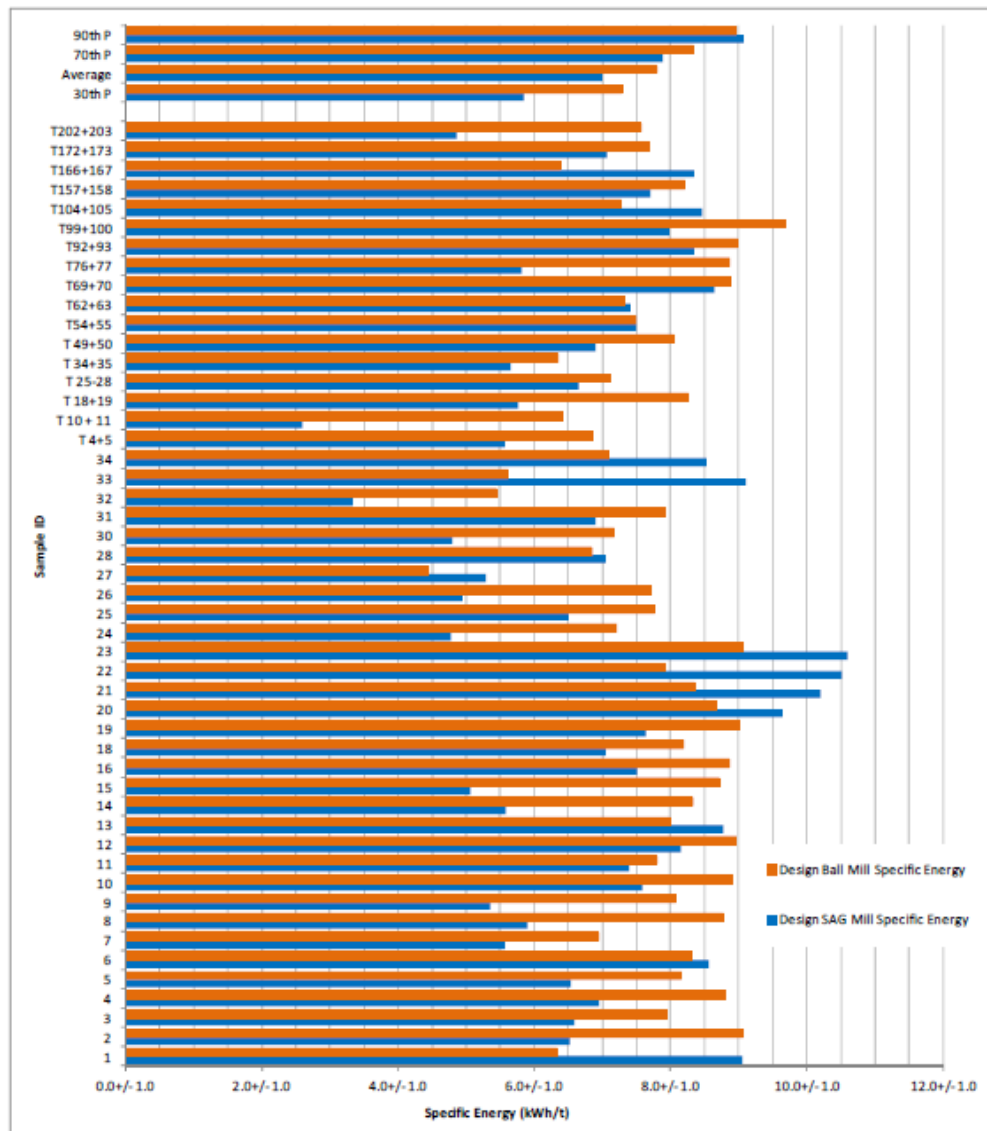
### **17.2.8.2 Blending Strategy**

The current design assumes sequential oxide or sulphide processing (batch processing) as opposed to blend processing as no provision has been made for a separate oxide rougher flotation circuit. Future work should ascertain that it is possible to mine selectively and stockpile the different ore types, or alternatively assess the metallurgical response of blends of ore types during the feasibility test work programme.

### **17.2.8.3 Plant Capacity**

The plant has been designed for a throughput of 30Mtpa. Since the design is somewhat conservative, it is likely that a 10% throughput increase will be possible, taking the throughput up to 33Mtpa when treating sulphide ore.

The mill selection is based on the 80<sup>th</sup> percentile hardness data, which translates to a specific energy of approximately 8.5kWh/t per mill. Circuit-specific energy shown below per variability sample shows that there is opportunity to achieve higher mill throughput when treating certain areas of the ore body.



16

**Figure 17-7: SABC Mill Specific Energy Predictions (kWh/t)**

In addition to exploiting ore variability characteristics, there is further opportunity to increase mill throughput by decreasing the SAG mill feed size by finer blasting. The design condition for the mills (at maximum power) is 14% above the designed duty point, so there is room to increase speed in the SAG mill and ball charge in both mills if needed.

The rougher flotation circuit can treat 33Mtpa if operated at an increased solids content of 40%. The slurry pipeline and DSTP system could also accommodate an increase in throughput of 10% if operated at a solids concentration of 57%. The pipe and valve size would not need to change. The wear rate would increase slightly. Minor adjustments have been made to the capital and operating cost estimate to take into account the higher throughput rate. Plant capacity and sizing requires review in the FS stage.

<sup>16</sup> OMC report, Yandera SAC and SABC Assessment for Arcccon (WA) Pty Ltd, report number 8887.30 Rev B dated 8<sup>th</sup> June 2012



#### 17.2.8.4 Oxide Ore Treatment

Technical peer review by SRK of the oxide circuit selection as discussed in Section 13.2.5 recommended that sizing of key equipment components require review in the subsequent study phase. Potentially longer residence times (33% increase) than provided for in the sulphide circuit design, as well as additional thickener settling area (20% increase), are the most significant items to address. This study accounted for the equipment sizing adjustments through minor adjustments to the capital cost estimate.<sup>17</sup>

### 17.3 Equipment Characteristics and Specifications

This section provides key sizing parameters for the major mechanical equipment items and discussion on equipment selection considerations.

#### 17.3.1 Comminution

##### 17.3.1.1 Primary Crusher

A single gyratory crusher has been selected for the primary crushing duty. These crushers are well suited to this scale of operation and are commonly used in the world's largest mines. There are a number of reputable vendors supplying and maintaining these units worldwide, namely Sandvik, Metso, Citic-HIC and FLSmidth amongst others. The crusher selection is aligned with the recommendation made by Orway Mineral Consultants (OMC)<sup>18</sup>.

OMC noted that a mineral sizer might be suitable as an alternative, since the samples tested show the ore to be soft and fractured. The UCS data, at an average of 45 MPa (max 91 MPa) and the abrasion index at an average of 0.17, make mineral sizers a feasible option. However, the historical test work for UCS determination was based on only four samples.

It is recommended that this option be explored further in the FS stage to assess ore properties based on a wider data set, including moisture, ore stickiness and/or clay content. Expected top size from mining and the influence of crusher product particle size distribution on SAG mill sizing and performance will require consideration.

A primary and secondary sizer arrangement may be preferable to a single sizer to avoid the need for oversize rejection and double handling. A trade-off study should consider total cost of ownership when comparing the two crusher types, as well as system flexibility to deal with ore variability.

##### 17.3.1.2 SAG and Ball Mills

The mills selected for the Project are among the largest in the world. The scale of operation requires two milling lines. The mill sizing and selection is based on recommendations made by OMC in Australia.

<sup>17</sup> SRK Consulting, Technical Memorandum: Review of Metallurgical Testwork of Yandera Copper Oxide, Project # 465300.060 dated 25 October 2017

<sup>18</sup> Yandera project SAC and SABC Assessment for Arcon (WA) Pty Ltd, OMC Report No. 8887.30 Rev B, dated 8th June 2012



### 17.3.1.2.1 Summary of Previous Mill Modelling/Sizing Work by OMC

OMC has been integrally involved historically with the Project and the FS in 2012 considered a number of circuit options including:

- Single stage SAG milling.
- SABC milling.
- Tertiary crush - ball milling.
- Secondary crush - HPGR - ball milling.

Results from this study are presented in OMC Report 8828.30.

The modelling was then refined further with a more detailed review being conducted on the single stage SAG and SABC options (OMC Report No. 8887.30 Rev B dated 8th June 2012). Both these studies were based on a target project throughput of 25Mtpa or 3,125 /h (8,000 hours/year milling) and grinding to P80 150 µm.

The entire database of results was modelled and the 70th percentile result selected as the design point. OMC noted that the 70th percentile design point used in this historical report was optimistic with no inbuilt contingency, and that prudence must be observed in using 70th percentile values in any economic evaluations.

Report number 8887.30-01 Rev A dated December 2012 considered OMC's review of the Yandera comminution circuit at an increased throughput of 30Mtpa or 3,643t/h (milling), inclusive of 70th and 80th percentile design data, grinding to P80 150 µm and 180 µm. In a single stage SAG configuration, the 25Mtpa target throughput could not be achieved using the 70th percentile results to 150 µm even using two of the largest SAG mills then available. Therefore, for the 30Mtpa scenario, single stage SAG milling was not considered a viable option.

OMC offered the following comment on the selection of a SABC circuit:

*"SAB or SABC circuits are the most commonly installed in modern copper concentrators and these are selected for good reason. A major number of porphyry copper ores are not grind sensitive, with the copper mineralization associated with grain boundaries. As such, the minerals are liberated early in the grinding process. These deposits are also often very large, low in grade and have reasonably consistent geology.*

*For this reason, throughput rather than grind size is the major economic driver, with large throughput rates ensuing. As a result, maximizing the throughput per grinding train to minimise the capital associated with stockpiles, feed systems and recycle conveyors is essential.*

*The installation of a two-stage grinding circuit maximises the installed power for a grinding train. Often two to three times the installed power of a single stage mill can be installed in a single SABC circuit.*

*Other large throughput porphyry copper SABC circuits in the PNG Cu/Au belt include Ok Tedi and the Freeport Grasberg mine, both treating over 20Mtpa."*





For the current study, Advisian has reverted to two SABC milling lines to treat 30Mtpa, based on utilization of the 80th percentile data for design, 8,000 operating hours per annum and a target grind size of 150um in line with OMC’s recommendations. The relevant mill sizing parameters that align with this selection were extracted from the various OMC reports listed above, and are summarized in the following section.

### 17.3.1.2.2 Specifications for Mills

**Table 17-6: Specifications for Mills**

Description		Units	Value
<b>SAG Milling</b>			
Number of grinding lines		-	2
Throughput (each line)		t/h	1,875
New feed size	F100 (max. lump size)	mm	250
New feed size	F80	mm	138
Specific power (no factors)		kWh/t	8.48
SAG mill pinion power (each line)		kW	15,900
Ball load	Operating	% v/v	12
	Design	% v/v	17
Total mill load	Operating	% v/v	25
	Design	% v/v	35
Maximum ball size (design)		mm	150
Mill discharge slurry density		% solids (w/w)	75
Mill diameter inside shell		m	11.58
Mill length grinding length (EGL)		m	7.47
Mill speed (% of critical speed )	Max	%	80
Mill speed (% of critical speed )	Typical	%	75
Drive type		-	Girth gear and Dual pinion
Motor power	Installed	kW	22,000
<b>SAG Mill Discharge Screen</b>			
Number per SAG mill			1
Type			Trommel
Screen aperture		mm	18
Screen panel material		-	rubber
<b>Ball Milling</b>			
Final product size	P80	µm	150
Specific power (no factors)		kWh/t	8.22
Specific power (with factors)		kWh/t	8.46



Description		Units	Value
Ball mill pinion power (each line)		kW	15,863
Ball load	Operating	% v/v	30
	Design	% v/v	35
Maximum ball size (design)		mm	80
Mill discharge slurry density		% solids (w/w)	75
Mill diameter inside shell		m	8.53
Mill length grinding length (EGL)		m	13.56
Mill speed (% of critical speed )	Fixed	%	75
Drive type		-	Girth gear and Dual pinion
Motor power	Installed	kW	22,000

### 17.3.1.2.3 Comment on Equipment Selection

The mills selected for Yandera are amongst the largest in the world. There are a number of references for similar sized mills in production in various locations and mineral sectors. Whilst gearless mill drives have been preferred in recent years for large mills, advances in gear drives indicate these to be a cheaper alternative with a lower lead-time.

A couple of case studies are presented here for consideration.

Geared vs Gearless Drive Solutions for grinding mills, Procemin2010 conference in Chile, presentation by Citic Heavy Industries

This paper presented in 2010 evaluated the merits of large geared mills versus gearless driven mills and drew the following conclusions:

- For mills above 12.2m in diameter or over 20MW of power, there is currently no viable alternative to a gearless drive.
- For mills 12.2m or less in diameter and 20MW or under in power, gear driven systems offer a more viable alternative to gearless drives, delivering nearly equivalent efficiency, much lower capital cost, easier installation, simpler cooling, shorter installation time and quicker (two to three months) project overall start-up schedule.

Autogenous and Semi-Autogenous Mills 2015 Update, SAG Conference Vancouver, March 2015, presented by Frank J. Tozlu and Moris Fresko

This paper references the author’s database of AG and SAG mill installations around the world, and shows the following trends:

- By early 2015, there were over 30 installations worldwide of 40-ft diameter AG/SAG mills.
- Ring motors (GMDs) are the preferred drives for larger mills; however, it is expected that gear drives will be able to transmit 28MW in the near future.



#### "MILL DRIVES

*The optimum selection of drives for AG/SAG mills is important for both the economics of the project and the successful operation of the plant. Advancements in the design and manufacturing capabilities for large gears have been achieved over the last five years. The largest single pinion/gear drive installed and operating to date is identified at 8,500kW. This is higher than the 7,500kW pinion drive mentioned five years ago. To date, 2 x 8,500kW = 17MW dual pinion drive ball mills have been sold and are presently operating since 2012. This marks the highest power dual pinion drive in the market today. Gearless Mill Drives (GMD) have been formally sold as large as 28,000kW. However, over the past three years, gear/pinion drive systems have made great technological advances, and will soon prove to be the better option when thinking about going well beyond 18MW.*

*The first SAG mills to use a GMD motor design were the two 32' x 17' (15' EGL) - 8,200kW SAG mills sold to Chuquicamata in Chile in 1986. Until today, 72 GMD SAG mills have been sold, the largest rated at 28MW (37,520 HP). In the past five years, 12 GMD AG/SAG mills have been added to the list compared to 40 over the previous period. The significance in the decline of installed GMD motors over the past five years may be due to the High Capex cost for these drives and mine owners are now looking to upgrade or improve their existing operations as mentioned earlier on the increase in ball milling power. It remains to be seen whether the latest 12.8m (42 ft) diameter SAG mill will be a new standard for large mills, or whether larger diameters will follow.*

#### CONCLUSION

*The AG/SAG mill market has been presented. The SAG mill (and in a limited way the SAG mill) will continue to be applied in the mining industry in a wide variety of applications. SAG mills and ball mills in the mining industry will continue its upward trend of growth in size with SAG mills up to 30MW and ball mills as large as 24MW. Conceptual design and pricing has been developed for gearless SAG mills of 44' (13.41m) diameter with 32MW (42,900 HP) and ball mills of 30' (9.14m) in diameter and 28MW (37,500 HP). Single grinding lines will process 200,000Mtpd of ore and more.*

*It is expected that large gear driven mills will approach 12 to 14MW for single drive systems and 24 to 28MW in dual drive systems. GMDs are currently preferred at these high-power inputs for comminution; however, innovative technologies are currently on their way in allowing users to stay with the gear driven mill solution. Engineers will begin to understand the convenience and long-term savings possible with these new drive systems being developed and tested."*

#### **17.3.1.2.4 Yandera Mill Selection**

Citic Heavy Industries have recommended dual pinion gear driven mills for Yandera. Subsequent project study phases should consider current best practice when making a selection of mill drives.

The availability of gearless drive OEMs (currently only two, ABB and Siemens) and the availability of specialized site/commissioning staff for erection and on-going support can be problematic if GMDs are selected.

#### **17.3.1.3 Pebble Crusher**

Cone crushers have been selected in the pebble crushing duty in line with OMC's recommendation.



#### **17.3.1.4 Regrind Mills**

Mill types capable of achieving the target regrind size of 38 and 28microns for Cu and Mo concentrates respectively are vertical stirred mills such as the Metso Vertimill®, or Outotec HIGmill™, or the Glencore Technology IsaMill™. The vertical stirred mill selected in the previous project phase was retained as these are a popular choice in similar applications and have the advantage of a small footprint. The choice of grinding media (steel/ceramic) and determination of the vendor-specific regrind energy requirement should be addressed in the next project phase.

#### **17.3.2 Pumps**

The cyclone feed pumps are the largest slurry pumps in the Yandera processing plant, with a nominal flowrate of approximately 8,000m<sup>3</sup>/hr. Heavy duty large centrifugal slurry pumps such as the Krebs MillMAX™ range are best suited to this application.

#### **17.3.3 Dewatering**

##### **17.3.3.1 Slurry and Tailings Thickeners**

The milled product from Yandera requires thickening ahead of overland transfer by pipeline to the flotation plant. A single thickener of 78m diameter or two units of 55m diameter each were considered. Two smaller units were selected, as this would provide redundancy and opportunity for staged construction of a single milling line if required. Vendor advice from FLSmidth indicated that smaller units are more cost effective due to a central rather than peripheral drive arrangement.

The largest diameter thickener design (steel tank and above ground) that FLSmidth currently supply is 50m. The thickeners selected for Yandera are 55m in ground concrete HRT thickeners, such as the unit installed at Lumwana mining company in Zambia.

The thickeners installed ahead of the tailings disposal system at the coastal facility are similar, i.e., two 55m diameter in ground HRT thickeners.

##### **17.3.3.2 Concentrate Thickeners**

High rate thickeners for Mo and Cu concentrate dewatering ahead of filtration have been sized at 2-m diameter and 15-m diameter respectively. Steel above ground thickeners will be used in these applications. The copper concentrate thickener is coupled with a 7-m diameter clarifier to treat the thickener overflow stream, as a safeguard for poor thickener operation and subsequent product loss to the process water pond.

##### **17.3.3.3 Concentrate Filtration**

The filter type selected for Cu concentrate filtration is a horizontal plate and frame filter press complete with automated discharge and cloth washing.

Cu concentrate filter selection should be reviewed following FS stage test work (i.e., confirmation of filtration rates and determination of concentrate TML and target moisture content for shipping.)



A tube press was selected for molybdenite concentrate filtration in the previous study phase, and this selection has been retained without further investigation for the current study as this is a minor piece of equipment.

### 17.3.4 Slurry Transfer Pipeline and DSTP System

This system has been designed by BRASS Engineering, the company responsible for the design and installation of a similar pipeline for the nearby Ramu Nico operation in PNG. Detail is provided in Section 18.1.6.

### 17.3.5 Flotation Cells

#### 17.3.5.1 Flotation Circuit – Technology Selection

With the exception of the molybdenite circuit, all flotation cells specified for the design were forced air flotation cells. These were specified in preference to self- aspirating cells for the following reasons:

- Lower capital cost.
- Forced air cells allow for independent control of air addition and level control, which is not possible for self-aspirated cells. This allows consistent pulling rates and steady concentrate grades, which is an advantage when froth cameras are used to optimize flotation concentrate grades and stabilise the flotation circuit downstream of the rougher circuit.
- Energy efficiency is achieved using new generation rotor/stator designs, such as the next STEP™ Rotor. This concept has been tested and proved to reduce power consumption between 20 to 40% in certain instances when compared to conventional forced air cell mechanisms.

The OEM has advised, however, that self-aspirating (Wemco) cells may be preferable in the rougher application, as these cells have demonstrated better recovery results during performance tests globally. This is the case in both coarse (+150microns) as well as finer material (less than 25microns). The OEM has indicated that while the Wemco cell cost can be up to 15% higher, this should be offset by the cost of the blower system and up to 5% recovery improvement. It is recommended that flotation cell selection be investigated in more detail in the next project phase.

#### 17.3.5.2 Rougher Cells

The bulk rougher scavenger flotation circuit has been configured as two trains consisting of seven 330m<sup>3</sup>-forced air tank cells per train.

FLSmidth Minerals SuperCells™ with a capacity ranging from 300m<sup>3</sup> to 350m<sup>3</sup> were the first cells of this size to be installed in 2009. Two cells were commissioned in the bulk copper-molybdenum flotation circuit at Rio Tinto's Kennecott Copperton Concentrator in Utah, USA.<sup>19</sup>

Subsequently, FLSmidth and Outotec have developed 500 and 600m<sup>3</sup> cells respectively. The trend is for larger equipment to be installed, and the development and installation of these cells

<sup>19</sup> <http://flsmidthminerals.com/2009december/2015/12/30/the-worlds-largest-and-most-efficient-flotation-cells>



should be investigated and the opportunity for improved capital and operational efficiency and lower energy consumption be explored in subsequent project phases.

**Table 17-7: Rougher Flotation Circuit Details**

Description	Unit	Value
<b>Bulk Rougher – Scavenger Flotation Cells</b>		
No. of bulk flotation trains	Each	2
Air/mech holdup allowance	% (v/v)	15
Cell type	-	Forced air
Cell volume (each)	m <sup>3</sup>	330
Selected number of cells (each train)	-	7

### 17.3.5.3 Copper Cleaner Cells

A single train of conventional forced air tank cells has been selected for the copper cleaner and cleaner scavenger applications. Cell sizes and quantities are shown in Table 17-8:

**Table 17-8: Cleaner Flotation Circuit Details**

Description	Unit	Value
No. of Cu Cleaner flotation trains	-	1
Air/mech holdup allowance	% (v/v)	15
Cell type	-	Forced air
<b>Copper Cleaner Circuit 1</b>		
Cell volume	m <sup>3</sup>	50
Selected number of cells	-	6
Copper Cleaner Circuit 2		
Cell volume	m <sup>3</sup>	50
Selected number of cells	-	4
<b>Copper Cleaner Scavenger Circuit</b>		
Cell volume	m <sup>3</sup>	50
Selected number of cells	-	3

### 17.3.5.4 Molybdenite Flotation

Inert cells such as the Wemco InertGas™ flotation machines are the most suitable technology to be used for the copper/molybdenite separation. NaHS is used as a reagent to suppress the flotation of copper. NaHS reacts with the oxygen in the air used for flotation and, therefore, increases consumption significantly.

With inert cell technology, the flotation cells are covered and sealed. Instead of drawing in air from the atmosphere, air is drawn from the headspace in the covered cell and continually recirculated. This recirculated gas soon becomes nearly “inert” and as a result, NaHS consumption is reduced dramatically, with savings quoted in the range of 30% to 50%





**Table 17-9: Molybdenite Flotation Circuit Details**

Description	Unit	Value
<b>Mo Rougher Flotation Circuit</b>		
No. of Mo rougher flotation trains	-	1
Air/mech holdup allowance	% (v/v)	15
Cell type	-	Inert Cell
Cell volume	m <sup>3</sup>	70
Selected number of cells	-	3
<b>Mo Cleaner Flotation Circuit</b>		
Air/mech holdup allowance	% (v/v)	10
Cell type	-	Inert Cell
Number of cleaner flotation trains, per stage	-	1
<b>Mo Cleaner 1 Flotation</b>		
Cell volume	m <sup>3</sup>	8.0
Selected number of cells	-	5
<b>Mo Cleaner 2 Flotation</b>		
Cell volume	m <sup>3</sup>	8.0
Selected number of cells	-	2
<b>Mo Cleaner 3 Flotation</b>		
Cell volume	m <sup>3</sup>	5.0
Selected number of cells	-	2
<b>Mo Cleaner 4 Flotation</b>		
Cell volume	m <sup>3</sup>	5.0
Selected number of cells	-	1
<b>Mo Cleaner 5 Flotation</b>		
Cell volume	m <sup>3</sup>	5.0
Selected number of cells	-	1
<b>Mo Cleaner 6 Flotation</b>		
Cell volume	m <sup>3</sup>	5.0
Selected number of cells	-	1
<b>Mo Cleaner 7 Flotation</b>		
Cell volume	m <sup>3</sup>	5.0
Selected number of cells	-	1



## 17.3.6 Materials Handling

### 17.3.6.1 Conveyors

Details relating to belt speeds, capacity, loading and angles can be found in the mechanical design criteria, referenced in the appendix to this section.

### 17.3.6.2 Bulk Concentrate Handling

Filtered concentrate is transferred from the flotation plant by overland conveyor, a distance of approximately 500m to a storage shed located at the wharf. Concentrate is tipped onto a covered stockpile and re-handled with front-end loader and track-mounted slewing/stacking conveyor for ship loading. The wharf is designed for HandyMax vessels, which typically collect bulk parcel sizes of 11,500 wet tonnes of concentrate. Concentrate collection for export is expected to take place twice monthly.



**Figure 17-8: Conceptual View of Copper Concentrate Ship Loading Operation**

## 17.3.7 Reagent Systems

A list of reagents and anticipated annual usage is included in Section 17.4. Delivery to the mine site will be by road, either in bulk containers or bags for powder reagents, and in drums or IBC containers for liquid reagents. Mixing and storage tanks are provided for powder reagents, in accordance with the appropriate hazardous category zoning, while liquid reagents will be dosed directly from the storage containers.

The flocculant mixing plants will be procured as vendor packages, with adequate hydration time as recommended by the suppliers, and inline dilution prior to dosing.



## 17.3.8 Utilities

### 17.3.8.1 Blowers

Two low-pressure air systems have been allowed for, to match the flotation cell vendor requirements in terms of flowrate and pressure. Details of these systems are provided in Table 17-10.

**Table 17-10: Blower System Details**

Description	Units	Value
<b>LPA System 1: Rougher-Scavenger Flotation Cells</b>		
LP air pressure (at manifold)	kPag	70
Maximum air flowrate for rougher-scavenger line (each)	Nm <sup>3</sup> /min	322
Number of rougher-scavenger lines	-	2
Design LPA System 1 air flow rate	Nm <sup>3</sup> /h	38,640
<b>LPA System 2: Cu Cleaner and Mo Rougher Flotation Cells</b>		
LP air pressure (at manifold), copper cleaners and Mo roughers	kPag	39-48
Maximum air flowrate, copper cleaners and Mo roughers	Nm <sup>3</sup> /h	7980
LP air pressure (at manifold), Mo cleaners	kPag	23-29
Maximum air flowrate, Mo cleaners	Nm <sup>3</sup> /h	1980
Design LPA System 2 air flow rate	Nm <sup>3</sup> /h	9,960

### 17.3.8.2 Raw/Fire and Potable Water

Provision has been made for a combined storage tank for raw and fire water at each project area. The tank will be designed such that a minimum level is maintained at all times, sufficient to provide the required volume of firewater. A dedicated diesel-driven firewater pump is provided in the event of a power failure.

Potable water is produced at the various plant and camp areas by dedicated water treatment plants sized for the local demand.

### 17.3.8.3 Compressed Air

The mine and milling area does not have site-wide compressed air reticulation. Dedicated local compressors are installed where required, e.g., workshops and tyre inflation bays. No provision has been made at the milling site for instrument air – the large diameter slurry pipelines and associated automated valves are best actuated hydraulically in the size range under consideration (500mm to 1,000mm pipe diameter). The smaller bore piping and valves related to the mill and crusher lubrication systems will be electric solenoid operated.

Provision is made at the flotation plant for compressed and instrument air supply and reticulation.



### 17.3.8.4 Sewage and Waste Treatment

Waste water and sewage from each facility is treated in a sewage plant, which has been specified as a vendor supplied packaged plant

## 17.4 Projected Requirements for Energy, Water and Process Materials

### 17.4.1 Energy Requirements

An electrical load list, water balance and consumables list was developed for the plant.

The load list was derived from preliminary equipment sizing and the mechanical equipment list. The load list includes the preliminary operating schedule and identifies installed/ absorbed power, redundancy and operating hours per annum for each item of equipment.

**Table 17-11: Summary of Installed and Absorbed Power – Process Plant**

Area	Absorbed Power, Total (kW)	Installed Power, Total (kW)	Emergency Power Installed, (kW)
Yandera On site Infrastructure (incl. crushing and milling)	87,253	111,890	1,839
Flotation Plant	9,649	15,034	1,968

Provision for emergency power covers the following major items:

Mill lubrication systems, thickener rakes and underflow recycle pumps, process water pumps at the milling precinct (for pipeline flushing), flotation conditioning tank and concentrate stock tank agitators and tower crane, concentrate filter hydraulic system, ship loading conveyor, potable water pumps and event pond pump at the coastal facility, and process water pumps at the coastal facility.

### 17.4.2 Plant Water Demand

A water balance for the process plant and mine facilities has been produced for steady state operation. It should be noted that the milling plant is water deficient due to no recovery of water from the tailings disposal system. As such, the milling plant requires process make up water in the order of 2450m<sup>3</sup>/hr. The mine is located in an area of high rainfall (5m per annum). Plant make up water will be partly sourced from pit dewatering for mining operations, and partly from the Imbruminda river. Further detail relating to the overall water balance and water management philosophy is provided in Section 18.14.

**Table 17-12: Yandera Plant and Facilities High Level Water Balance – Steady State Operation**

Water Flows In to Area						Water Flows Out of Area					
Source	Destination/User	Flowrate		Operating Schedule		Source	Destination	Flowrate		Operating Schedule	
<b>Yandera On Site Infrastructure and Milling Plant Area</b>											
<b>Mining - Operations</b>											
Raw water supply	Mine heavy vehicle wash bay	7.4	m <sup>3</sup> /hr	1095	hrs/annum	Wash bay effluent	Waste treatment	7.4	m <sup>3</sup> /hr	1095	hrs/annum
	WRD construction, dust suppression	123	m <sup>3</sup> /hr	3200	hrs/annum	WRD and Roads	Seepage & evaporation	123	m <sup>3</sup> /hr	3200	hrs/annum
<b>On Site Infrastructure</b>											
Potable water supply	Ablutions and mess	21	m <sup>3</sup> /day			Sewage	Waste treatment	21	m <sup>3</sup> /day		
	Safety showers	5	m <sup>3</sup> /day								
<b>Processing - Milling Plant Operations</b>											
Ore feed		417	m <sup>3</sup> /hr	8000	hrs/annum	Thickened slurry	Flotation plant	3068	m <sup>3</sup> /hr	8000	hrs/annum
Process water make-up		2450	m <sup>3</sup> /hr	8000	hrs/annum	Mill cooling	Evaporation	20	m <sup>3</sup> /hr	8000	hrs/annum
Raw water supply	Milling plant make-up	221	m <sup>3</sup> /hr	8000	hrs/annum						
<b>Total</b>		<b>3088</b>	<b>m<sup>3</sup>/hr</b>	<b>8000</b>	<b>hrs/annum</b>	<b>Total</b>		<b>3088</b>	<b>m<sup>3</sup>/hr</b>	<b>8000</b>	<b>hrs/annum</b>
<b>Mangiai Camp Area</b>											
Raw water supply	Fire water	20	m <sup>3</sup> /hr	10	hrs/annum	Waste Treatment		49.4	m <sup>3</sup> /day		
Potable Water Supply		49.4	m <sup>3</sup> /day								



Water Flows In to Area						Water Flows Out of Area					
Source	Destination/User	Flowrate			Operating Schedule	Source	Destination	Flowrate			Operating Schedule
Slurry Feed		3,068	m <sup>3</sup> /hr	8000	hrs/annum	Tailings	DSTP	3156	m <sup>3</sup> /hr	8000	hrs/annum
Coastal Facilities Area (Flotation Plant and Camp)											
Raw water supply		92	m <sup>3</sup> /hr	8000	hrs/annum	Cu Concentrate	Despatch by ship	3.91	m <sup>3</sup> /hr		
						Mo Concentrate	Despatch by ship	0.04	m <sup>3</sup> /hr		
						Mo Dryer	Evaporation	0.07	m <sup>3</sup> /hr		
<b>Total</b>		<b>3160</b>	<b>m<sup>3</sup>/hr</b>	<b>8000</b>	<b>hrs/annum</b>	<b>Total</b>		<b>3160</b>	<b>m<sup>3</sup>/hr</b>	<b>8000</b>	<b>hrs/annum</b>
Potable water supply	Ablutions and mess	40	m <sup>3</sup> /day			Waste Treatment		40	m <sup>3</sup> /hr		
	Safety showers	5	m <sup>3</sup> /day								





### 17.4.3 Process Consumables Required

The consumables list is extracted from the process design criteria, and informed by metallurgical test work. Major consumables required for the milling and flotation sites are summarized in the table below:

**Table 17-13: Flotation Plant Reagent and Media Consumption Schedule – Sulphide Ore**

Name	Chemical Name	Transport Form	Consumption (g/t)	Ore throughput (tpa)	Consumption basis	Consumption Rate (t/pa)
Collector – PAX	Potassium Amyl Xanthate	Powder	50	30	Tonnes milled	1,500
Frother – MIBC	Methyl Isobutyl Carbinol	Liquid	40	30	Tonnes milled	1,200
Flocculant (tailings)	Magnafloc 800HP	Powder	15	30	Tonnes milled	450
Flocculant (Cu concentrate)	Magnafloc 155	Powder	22.5	0.32	tonnes Copper Concentrate	7.3
Coagulant	Magnafloc LTE 425	Liquid	10	30	Tonnes milled	300
Grinding Beads (3-12mm)	Ceramic/steel	Solids (bulk container)	0.86	0.672	tonnes bulk conc.	578

**Table 17-14: Flotation Plant Reagent and Media Consumption Schedule – Oxide Ore**

Name	Chemical Name	Transport Form	Consumption (g/t)	Ore throughput (tpa)	Consumption basis	Consumption Rate (tpa)
Collector – PAX	Potassium Amyl Xanthate	Powder	200	30	Tonnes milled	6,000
NaHS	Sodium Hydrosulphide	Flakes	650	30	Tonnes milled	19,500
Collector (oxide) – OX-100	Alkyl hydroxamic acid	Powder	100	30	Tonnes milled	3,000
Frother – MIBC	Methyl Isobutyl Carbinol	Liquid	40	30	Tonnes milled	1,200
Flocculant (tailings)	Magnafloc 800HP	Powder	15	30	Tonnes milled	450
Flocculant (Cu concentrate)	Magnafloc 155	Powder	22.5	0.29	tonnes Copper Concentrate	6.5
Coagulant	Magnafloc LTE 425	Liquid	10	30	Tonnes milled	300
Grinding Beads (3-12mm)	Ceramic/steel	Solids (bulk container)	0.86	1.05	tonnes bulk conc	903



**Table 17-15: Milling Plant Reagent and Media Consumption Schedule**

Name	Chemical Name	Transport Form	Consumption (g/t)	Ore throughput (tpa)	Consumption basis	Consumption Rate (tpa)
Flocculant (milled slurry)	Magnafloc 800HP	Powder	15	30,000,000	Tonnes milled	450
Coagulant	Magnafloc LTE 425	Liquid	10	30,000,000	Tonnes milled	300
Grinding Balls (125-150mm)	Carbon steel	Solids (bulk container)	0.32	30,000,000	Tonnes milled	9,600
Grinding Balls (65-80mm)	Carbon steel	Solids (bulk container)	0.4	30,000,000	Tonnes milled	12,000
Grinding Beads (3-12mm)	Ceramic/steel	Solids (bulk container)	0.86	672,000	tonnes bulk conc	578
Mill Liners	Steel/rubber	Solids (pallets)	0.05	30,000,000	Tonnes milled	1,500

## 17.5 Risk

### 17.5.1 Hazard and Operability Study

The Project PFS team conducted a Hazard and Operability study (Hazop) with the process and engineering disciplines to understand the fundamental hazards associated with the design, construction and operation of the process plant, as well as the associated surface infrastructure required to support and operate the plant. The findings are documented in the report titled Yandera Hazop2 report reference number C00651-0000-PR-REP-0003. This study should be revisited during subsequent project development phases to ensure that risks are adequately addressed and identified.

Risks associated with the use of reagents are as follows:

- Sodium hydrosulphide (NaHS) is a corrosive and toxic liquid, which will release toxic hydrogen sulphide (H<sub>2</sub>S) gas when exposed to heat or acids.
- Potassium amyl xanthate (PAX) is better shipped as a solid rather than a liquid, as solid xanthates are stable when kept cool and dry.

Precautions to be taken during handling and storage of these reagents is specified in the product Material Safety Data Sheets (MSDS), these are included in an appendix of the Hazop study report.

### 17.5.2 Project Risks

Project technical risks associated with processing and metallurgical test work are captured below:

- Risk of not achieving target metallurgical performance (recovery and concentrate grade) due to poorly predicted mineral and metallurgical feed characteristics.
- Risk of not achieving target throughput.



The forward work plan for metallurgical testing ahead of the DFS aims to reduce these risks through:

- Understanding feed characteristics, specifically mineralogy.
- Understanding the spatial distribution of feed mineralogy within the ore body, and the selected mine plan (variability).

Further risks associated with processing are discussed below:

- Risk of longer than planned commissioning and ramp-up period – a three-month period has been allowed for commissioning with specialist support by OEMs. Commissioning has been successfully completed on other new concentrator installations in a similar period. The mine production schedule does not ramp up to full production immediately; therefore, the risk of not achieving nameplate capacity is low, as there is time available for plant optimization during the initial years of operation.
- Skills availability – this will need to be addressed through early engagement and training, and collaboration with regional mine operators. Expatriate staff are envisaged in key positions at the outset, with a training programme to be implemented to transition some of these roles to local personnel over a two- to three-year period.
- Technology risk - the flowsheet selected presents a low level of risk in terms of technology selection. The unit operations and equipment selected are commonplace and widely used around the world in similar applications.

## 17.6 Reference Documents and Drawings

The documents and drawings listed in this section were produced in support of the engineering design and cost estimation for the milling and flotation plant for the PFS.

**Table 17-16: Engineering Design Documents for the Yandera Process Plant**

Document Title	Document Reference Number
Yandera Hazop 2 report	C00651-0000-PR-REP-0003
Basis of Design	C00651-0000-PM-BOD-0001 Rev C
Manning Estimate – Process Plant	C00651-0000-PR-LST-0002
Process Consumables Cost Schedule	C00651-0000-PR-LST-0003
<b>Design Criteria</b>	
Process Design Criteria and Mass Balance	C00651-0000-PR-CRT-0001 Rev A
Mechanical Design Criteria	C00651-0000-ME-CRT-0001 Rev 0
Civil and Structural Design Criteria	C00651-0000-CI-CRT-0001 Rev C
Electrical Design Criteria	C00651-0000-EN-CRT-0001 Rev C
Piping Design Criteria	C00651-0000-PE-CRT-0001 Rev 0
Mechanical Equipment list	C00651-0500-ME-LST-0001
<b>Data sheets for Mechanical Equipment</b>	
Cyclone Feed Pumps Data sheet	C00651-0000-ME-DAS-0001
Primary Crusher Data sheet	C00651-1400-ME-DAS-0001
Process Water Pump 1 data sheet	C00651-3100-ME-DAS-0001
Process Water Pump 2 data sheet	C00651-5300-ME-DAS-0001



Document Title	Document Reference Number
Thickener Underflow Pump Data sheet	C00651-5400-ME-DAS-0001
<b>Schedules for Mechanical Equipment</b>	
Conveyors Schedule	C00651-0000-ME-SCH-0007
Agitators,	C00651-0000-ME-SCH-0010
Lifting Equipment,	C00651-0000-ME-SCH-0015
Platework,	C00651-0000-ME-SCH-0014
Centrifugal Slurry Pump Schedule	C00651-0000-ME-SCH-0001
Centrifugal Water Pump Schedule	C00651-0000-ME-SCH-0002
Crane and Hoist Schedule	C00651-0000-ME-SCH-0009
Cyclone Schedule	C00651-0000-ME-SCH-0008
Diesel Pump Schedule	C00651-0000-ME-SCH-0012
Diesel Tank Schedule	C00651-0000-ME-SCH-0013
Fire water Pump List	C00651-0000-ME-SCH-0011
Froth Pump Schedule	C00651-0000-ME-SCH-0003
Mono Pump Schedule	C00651-0000-ME-SCH-0004
Peristaltic Pump List	C00651-0000-ME-SCH-0005
Spillage Pump Schedule	C00651-0000-ME-SCH-0006
<b>Specifications for Mechanical Equipment</b>	
Diesel Equipment Specification	C00651-0000-ME-SPC-0010
Flocculant Plant Specification	C00651-0500-ME-SPC-0001
Flotation Cells Specification	C00651-5100-ME-SPC-0001
Potable Water Treatment Plant	C00651-0000-ME-SPC-0008
Regrind Mills	C00651-5100-ME-SPC-0004
Slurry Pump Specification	C00651-0000-ME-SPC-0001
Specification for Agitators	C00651-0000-ME-SPC-0004
Specification for Blowers	C00651-5100-ME-SPC-0002
Specification for Compressed Air	C00651-0000-ME-SPC-0009
Specification for Cyclones	C00651-0000-ME-SPC-0005
Specification for Filter Press	C00651-5100-ME-SPC-0003
Specification for Gyratory Crusher	C00651-1400-ME-SPC-0001
Specification for Pebble Crushing	C00651-3200-ME-SPC-0001
Specification for SAG Mills and Ball Mills	C00651-3000-ME-SPC-0001
Specification for Ship Loading Conveyor	C00651-5200-ME-SPC-0001
Specification for Tube Press	C00651-5100-ME-SPC-0005
Specification for Vibrating Feeders	C00651-3200-ME-SPC-0002
Structural Mechanical Piping and Platework Scope	C00651-0000-ME-SPC-0011
Thickeners Specification	C00651-0000-ME-SPC-0003
Trash Screen specification	C00651-5100-ME-SPC-0006
Water Pump Specification	C00651-0000-ME-SPC-0002
<b>Specifications for Electrical Equipment</b>	
Specification for Skid Mounted Mini-Subs	C00651-0000-EL-SPC-0007
Specification for HV Switchgear	C00651-0000-EL-SPC-0001
Specification for LV Switchgear	C00651-0000-EL-SPC-0005
Specification for Power Transformers	C00651-0000-EL-SPC-0003



Document Title	Document Reference Number
Specification for Pre-Fabricated Switchrooms	C00651-0000-EL-SPC-0002
Specification for Standby Diesel Generators	C00651-0000-EL-SPC-0009
Specification for VSD's	C00651-0000-EL-SPC-0006
<b>Specifications for Piping</b>	
Manual Valve Supply Specification	C00651-0000-PE-SPC-0001
Metallic Piping Fabrication, Installation and Testing Specification	C00651-0000-PE-SPC-0002
Metallic Piping Supply Specification	C00651-0000-PE-SPC-0003
Piping Corrosion Protection Specification	C00651-0000-PE-SPC-0004
Piping Line Class and Material Specification	C00651-0000-PE-SPC-0005
Thermoplastic Piping Fabrication, Installation and Testing Specification	C00651-0000-PE-SPC-0006
Thermoplastic Piping Supply Specification	C00651-0000-PE-SPC-0007

**Table 17-17: Engineering Drawings for the Yandera Process Plant**

Drawing Title	Drawing Reference Number
Yandera Crusher and Stockpile Process Flow Diagram	C00651-0500-PR-PFD-0001-001 Rev C
Yandera Milling Plant Process Flow Diagram	C00651-0500-PR-PFD-0001-002 Rev C
Yandera Slurry Thickeners Process Flow Diagram	C00651-0500-PR-PFD-0001-003 Rev C
Yandera Reagents and Services Process Flow Diagram	C00651-0500-PR-PFD-0001-004 Rev C
Yandera Water Supply and Management Process Flow Diagram	C00651-0500-PR-PFD-0001-005 Rev C
Coastal Services Copper Concentration Process Flow Diagram	C00651-0500-PR-PFD-0001-006 Rev C
Coastal Facilities Tailings Dewatering Process Flow Diagram	C00651-0500-PR-PFD-0001-007 Rev C
Coastal Facilities Molybdenite Concentration Process Flow Diagram	C00651-0500-PR-PFD-0001-008 Rev C
Coastal Facilities Copper Concentrate Dewatering and Handling Process Flow Diagram	C00651-0500-PR-PFD-0001-009 Rev C
Coastal Facilities Reagents Process Flow Diagram	C00651-0500-PR-PFD-0001-010 Rev C
Coastal Services – Services Process Flow Diagram	C00651-0500-PR-PFD-0001-011 Rev C
Coastal Facilities – Camp Services Process Flow Diagram	C00651-0500-PR-PFD-0001-012 Rev C
Coastal Services – Services and Utilities Process Flow Diagram	C00651-0500-PR-PFD-0001-013 Rev C
Banu Facilities Services Process Flow Diagram	C00651-0500-PR-PFD-0001-014 Rev C
Yandera Mine Area Services Process Flow Diagram	C00651-0500-PR-PFD-0001-015 Rev C
Yandera Mangai Camp Services Process Flow Diagram	C00651-0500-PR-PFD-0001-016 Rev C
Site Layout – Yandera Precinct	C00651-3300-GE-DAL-0001-001 Rev B1
Yandera - Milling Plant Layout - Plot Plan Layout	C00651-3000-CI-DAL-0001-001 Rev C2
Yandera - Milling Plant - Sections	C00651-3000-CI-DAL-0001-002 Rev C
Yandera - Milling Plant - Sections	C00651-3000-CI-DAL-0001-003 Rev C
Yandera - Milling Plant - Sections	C00651-3000-CI-DAL-0001-004 Rev C
Yandera - Milling Plant Feed Conveyor - Feeder Tunnels	C00651-3000-CI-DAL-0001-005 Rev C



<b>Drawing Title</b>	<b>Drawing Reference Number</b>
Milling Plant Crusher General Arrangement	C00651-3000-CI-DAL-0002-01 Rev C
Milling Plant Pebble Crusher General Arrangement	C00651-3000-CI-DAL-0003-01 Rev C
Yandera - Milling Plant - Air and Diesel Piping Layout	C00651-3000-PI-DAL-0001-001 Rev A
Yandera - Milling Plant - Floc and Slurry Piping Layout	C00651-3000-PI-DAL-0001-002 Rev A
Yandera - Milling Plant - Raw and Potable Water Piping Layout	C00651-3000-PI-DAL-0001-003 Rev A
Yandera - Coastal Facilities – Process Plant –Location Plan Layout	C00651-5000-GE-DAL-0001-001 Rev B1
Yandera - Coastal Facilities - Camp & Process Plant - Layout	C00651-5000-CI-DAL-0001-001 Rev C
Yandera - Coastal Facilities - Process Plant - Layout	C00651-5000-CI-DAL-0001-002 Rev C
Yandera - Coastal Facilities - Cu Flotation/Roughers/Recovery Circuit - Layout	C00651-5000-CI-DAL-0001-004 Rev C
Yandera - Coastal Facilities - Plant Water Schematic Pipe Layout	C00651-5000-PI-DAL-0001-001 Rev C
Yandera - Coastal Facilities - Plant Concentrate Schematic Pipe Layout	C00651-5000-PI-DAL-0001-002 Rev B1
Yandera - Coastal Facilities - Plant Air Schematic Pipe Layout	C00651-5000-PI-DAL-0001-003 Rev B1
Yandera - Flotation Plant - Bulk Rougher Flotation Machines	C00651-5100-GE-DAL-0002-002 Rev C
Yandera - Flotation Plant - Copper Cleaner & Scavenger Flotation	C00651-5100-GE-DAL-0002-003 Rev C
Yandera - Flotation Plant - Plan View Sections & Elevations Molybdenite Flotation Area	C00651-5100-GE-DAL-0002-004 Rev C
Yandera - Flotation Plant - Plan View Sections & Elevations Copper Concentrate Filter Assembly	C00651-5100-GE-DAL-0002-005 Rev C
Yandera - Flotation Plant - Copper Filter Discharge Conveyor	C00651-5100-ME-DAL-0001-001 Rev C
Yandera - Wharf / Port Area - Ship Loading Facility General Layout - Plan View	C00651-5200-GE-DAL-0001-001 Rev B
Yandera – Coastal Facilities - Cape Rigny Infrastructure - Stores & Workshop General Layout - Plan View	C00651-5000-CI-DAL-0001-003 Rev C
Yandera Project – Mine Site – High Voltage (HV) Single Line Diagram (Sheet 1 of 3)	C00651-0000-EL-DSL-0001-001 Rev A
Yandera Project – Mine Site – High Voltage (HV) Single Line Diagram (Sheet 2 of 3)	C00651-0000-EL-DSL-0001-002 Rev A
Yandera Project – Cape Rigny Facility – High Voltage (HV) Single Line Diagram (Sheet 3 of 3)	C00651-0000-EL-DSL-0001-003 Rev A





## 18 Project Infrastructure

### 18.1 Introduction

The Yandera mine is located in the southwestern portion of Madang Province in the central highlands of PNG at elevations ranging from 1,500m to 2,400m above mean sea level in steep terrain with relatively high annual rainfall. The coastal facilities are located at Cape Rigny at mean sea level. The mine is in the same porphyry belt that hosts Ok Tedi and Grasberg to the west. Climate at the mine is that of a high-elevation tropical, equatorial environment. Humidity is high and precipitation is frequent. Skies tend to be clear early in the morning but by late morning and for the remainder of the day the skies can be cloudy with reduced visibility conditions.

The location of the Project relative to other major mineral projects on the island of New Guinea as shown in Figure 18-1 below.



Figure 18-1: Site Location

### 18.2 Project Infrastructure

This section describes the infrastructural work that will be required for the Project. The project infrastructure includes regional and local infrastructure. Facilities are required at Yandera to support mining and milling activities. The balance of processing will take place at the flotation plant located at Cape Rigny. The coastal facilities include associated infrastructure. The Yandera to Cape Rigny link comprises the ore slurry pipeline, access roads and power transmission lines.



**Figure 18-2: Yandera Project Infrastructure**

Figure 18-2 above shows the Cape Rigny coastal facilities and the access road from the coast, to the Ramu highway, connecting to the proposed new access road and the project site.

A breakdown of the key infrastructure is provided in the subsections to follow.

### 18.2.1 Regional Infrastructure

Existing regional infrastructure:

- Marine ports of Madang and Lae.
- Road network including Ramu and Highlands Highway.
- Airport at Madang.
- Satellite telecommunication network.

Regional infrastructure required to support the Project, in addition to existing facilities:

- Mine access roads from the Ramu Highway to the project site.
- Barging facility connecting Cape Rigny and Madang.
- Wharf facility at Cape Rigny.
- Slurry transfer pipeline from Yandera to Cape Rigny.
- Electrical power generation plant at Cape Rigny and the electrical supply infrastructure to Yandera.
- Telecommunication and internet services upgrading.



## 18.2.2 Local Infrastructure

Local infrastructure relates to all required infrastructure on the mine site and at the coastal facilities and is sub-divided into the following areas:

### 18.2.2.1 Mining Precinct Area

The infrastructure in this area will consist of following, as shown in Figure 18-3:

- Electrical distribution and incomer substation.
- Ore and waste handling systems.
- Aggregate quarry.
- Milling plant.
- Water supply and dewatering systems.
- Workshops and refuelling facilities.
- Security, stores and warehousing.
- Administration building and change room.
- Control room and medical station.
- Industrial and domestic waste handling facilities.
- Waste rock dump and bulk ore stockpile.
- Fire water system.
- Potable water treatment plant and storage tank.
- Sewage system.
- Camp at Yandera.



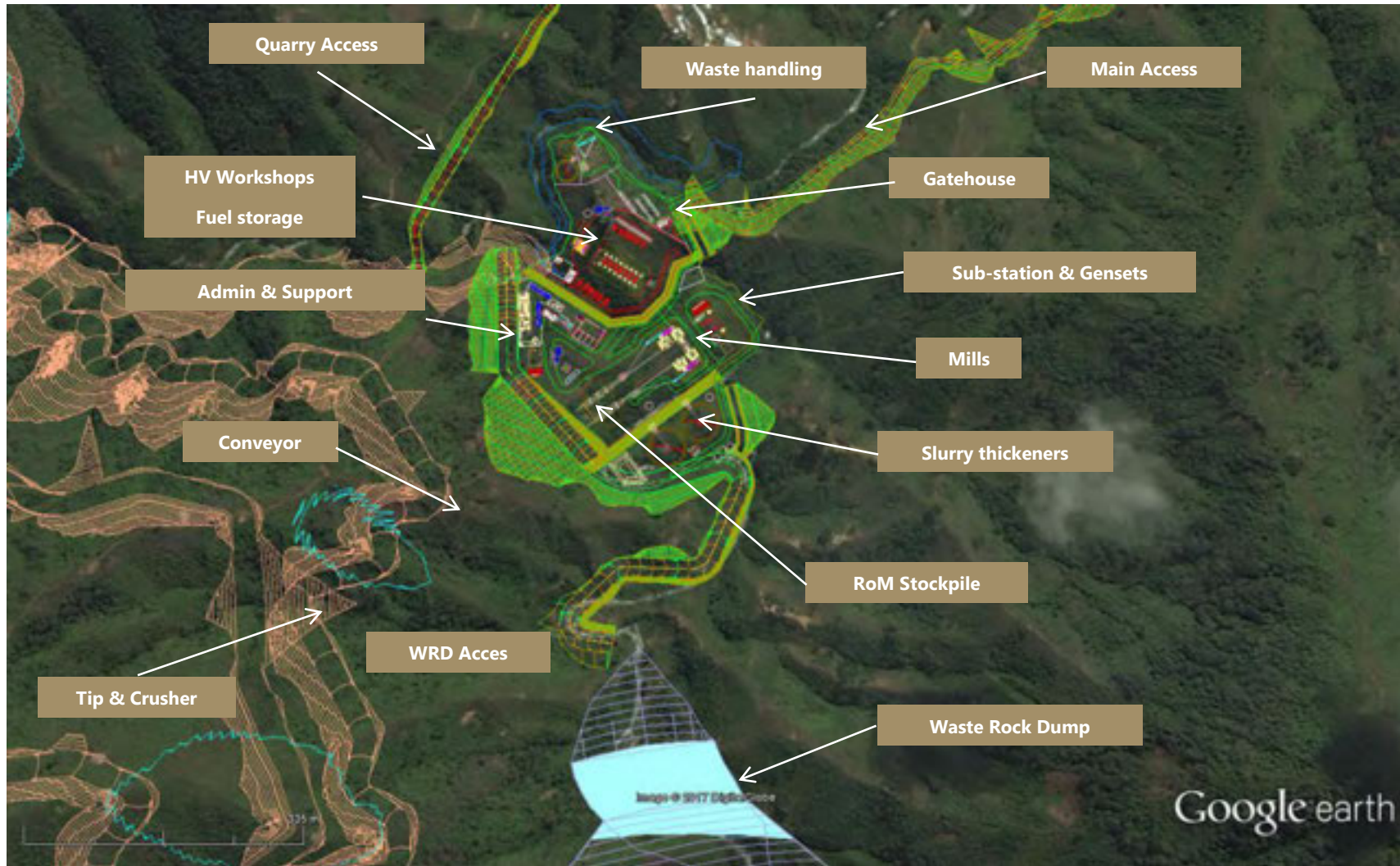


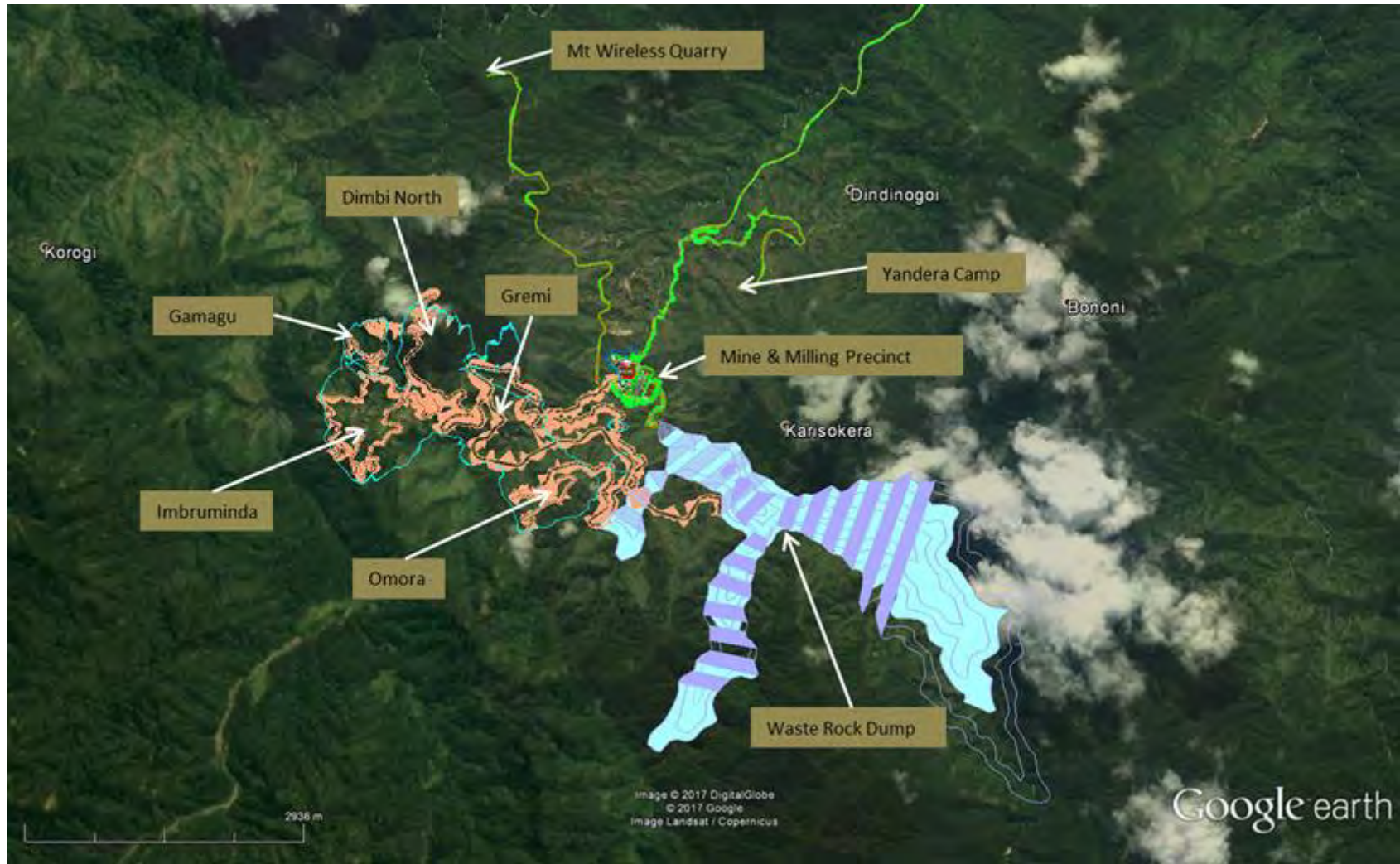
Figure 18-3: Yandera Mining Precinct



### 18.2.2.2 Mining Pit Area and Waste Rock Dump

The infrastructure will consist of following:

- Initial haul, service and access roads from the mine precinct to various pits and the waste rock dump.
- Hilltop access roads for the respective mining areas.
- Electrical reticulation for supplying mining and dewatering loads, including the trolley-assist infrastructure.
- Pit dewatering systems.



**Figure 18-4: Mining Pit Areas and Waste Rock Dump**





### 18.2.2.3 Coastal Facilities

The infrastructure in this area will consist of following, and is depicted in Figure 18-5:

- Electrical distribution and incomer sub-station.
- Barge facilities for loading and off-loading of cargo and personnel.
- Wharf facility to service the Cape Rigny facilities.
- Aggregate quarry.
- Flotation plant.
- DSTP system.
- Concentrate handling systems.
- Security, stores, workshops and warehousing.
- Administration building and change room.
- Control room and medical station.
- Industrial and domestic waste handling facilities.
- Fire water system.
- Water treatment plant and storage tank.
- Sewage system.
- Camp at Cape Rigny.

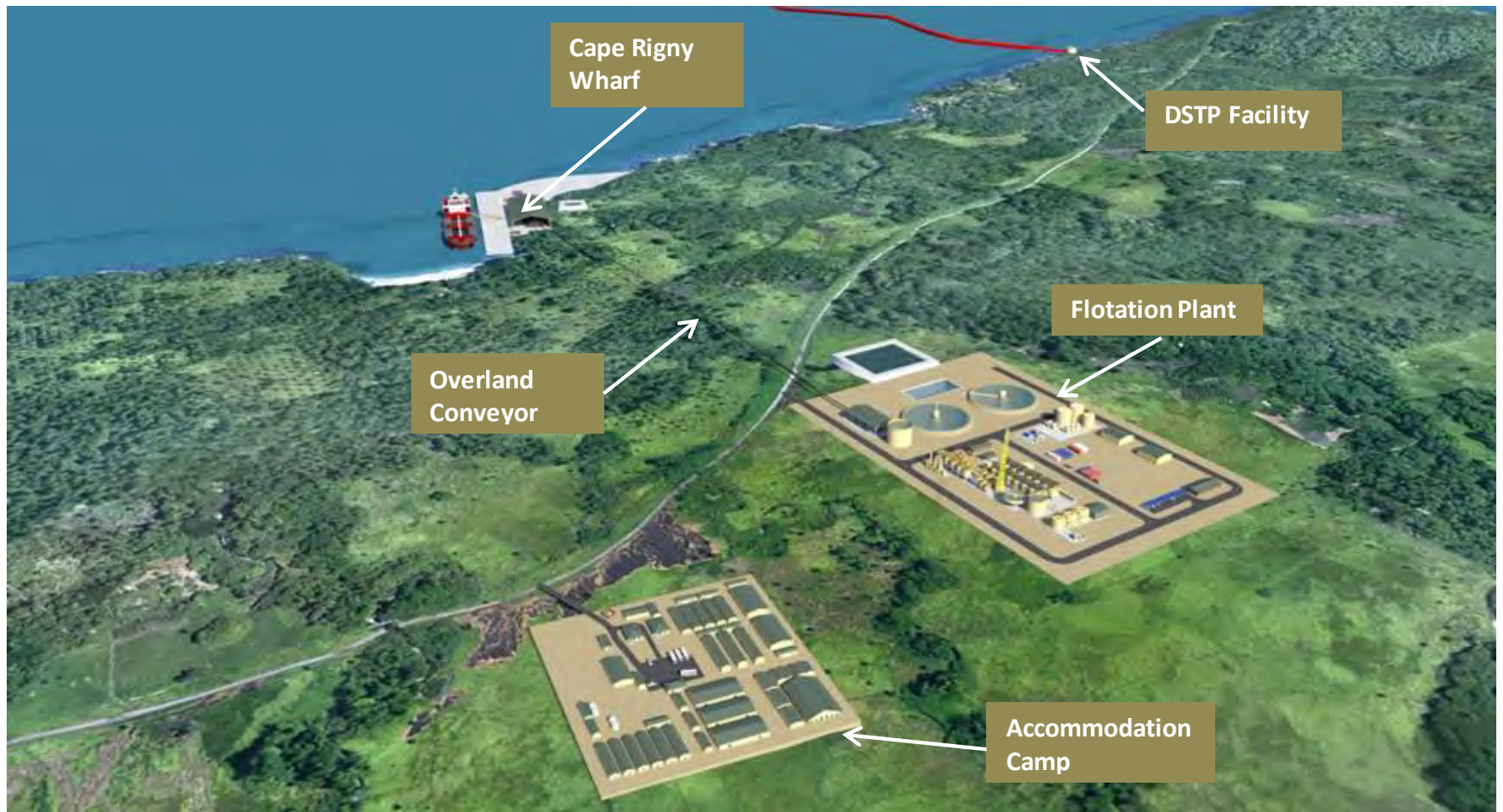


Figure 18-5: Conceptual Layout of Coastal Facilities at Cape Rigny



## 18.3 Power Supply and Distribution

### 18.3.1 Bulk Power Supply

The bulk electricity supply for the Project is being planned to cater for mining and plant production rates of up to 33Mtpa, which correspond to an estimated electrical load of up to 225MVA.

Electrical power will be supplied by an Independent Power Generating (IPG) supplier and be transmitted to the Cape Rigny and mine precinct, respectively. The power will be an “Over-the-fence” supply and the battery limits are on the 33kV and 11kV sides of the consumer sub-stations at Yandera and Cape Rigny, respectively. The IPG scope will include the following electricity supply infrastructure:

- power generating plant and supporting facilities;
- high voltage (HV) overhead lines from the generating plant to the mine precinct sub-station;
- transmission lines from the generating plant to Cape Rigny facility sub-station; and
- HV outdoor switching sub-stations and 33kV step-down substations.

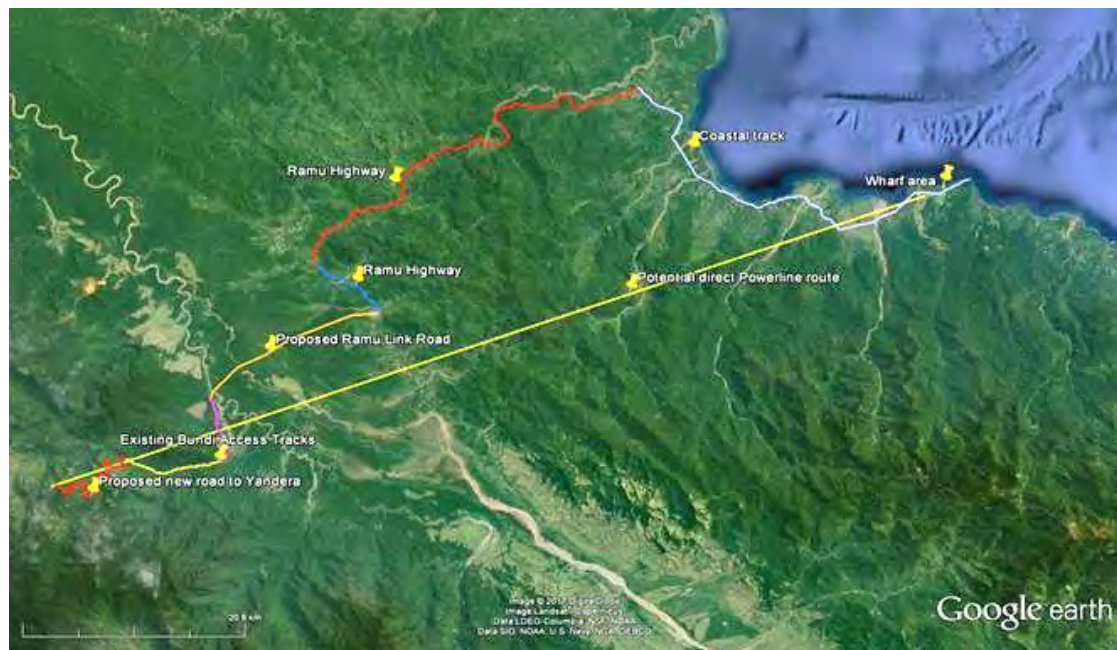


Figure 18-6: Potential Overhead Line Route

### 18.3.2 Predicted Electrical Load

The steady state load was calculated at 225MW at full production and will decrease towards the end of the mine life.



### 18.3.3 Temporary Power Supply

Temporary power supply will be required for the following:

- Camps at Yandera and Cape Rigny.
- Aggregate quarries.
- Building construction sites.
- Water extraction and treatment.

The emergency power generation stations for the Project are to be deployed in time to supply initial construction power as stipulated above. The sizing and selection of the generating plant equipment considers the construction and permanent loads at both the coastal as well as the precinct areas. Estimated construction loads are considered less than the emergency load requirements. The temporary power supply at the Mt Wireless and Cape Rigny quarries will receive electrical supply from one of the modular power generators at Yandera and the coastal facilities. At the time that operations at the quarries are discontinued, the generators will be relocated to the permanent positions at the consumer sub-stations of both the Yandera and Cape Rigny facilities.

### 18.3.4 Permanent Site Electrical Distribution

#### 18.3.4.1 Mine and Milling Precinct

The IPG supplies 33kV to the main consumer substation at the precinct where this supply is transformed to 11kV and distributed to the following areas:

- Materials handling system that includes the tip and crushing station.
- Milling plant.
- Water extraction and treatment plant.
- Slurry line system.
- Administration and control building.
- Main workshops.
- Stores and security.
- Camp.
- Sewage and water treatment plants.

#### 18.3.4.2 Mine Pit Areas

Whilst the initial haul and access roads are being developed, there will be 11kV and 33kV supply from the mine precinct to the mining areas. The 33kV supply will supply the trolley-assist system whilst the 11kV will be supplying the mine pit loads. Each point of supply at the pit areas will be equipped with ring main units and miniature sub-stations for low voltage reticulation to the in-pit loads (such as pumps, lights etc.). Once the permanent haul roads have been established, this reticulation will be replaced with a permanent reticulation system in the new locations.





### 18.3.4.3 Waste Rock Dump

A 33kV supply for a trolley-assist reticulation and system provided for the waste rock transport.

### 18.3.4.4 Coastal Facilities

Distribution of supply would be through the flotation plant consumer sub-station to the following areas:

- Flotation plant.
- Camp.
- Wharf area.
- Water extraction system.
- DSTP facility.

### 18.3.5 Emergency Power Supply

Emergency generators will be installed at both the Cape Rigny and the mine precinct consumer sub-stations, suitably sized to supply the emergency loads. The loads provided for are as follows:

- Slurry feed line.
- Thickener rakes.
- Thickener circulating pumps.
- Process water pumps for flushing.
- Potable water pumps.
- Agitator tanks.
- Ship loading conveyor.
- Camps.
- Control room UPSs.
- Emergency lighting.

All other activities will cease and can only resume once the regular supply has been restored. The emergency loads will be shed in order of priority and only essential loads will be supplied for the duration of the power outage.

## 18.4 Roads

Most of the equipment and goods for the Project will be transported within PNG from the Port of Lae via the Highlands Highway to Watarais and from there via the Ramu Highway to Walium. Alternatively, the Port of Madang may be used as port of entry into PNG and then the equipment and goods will be transported via the Ramu Highway from Madang to Walium. These main roads are predominantly sealed highways in fair to poor condition with short gravel sections. The section of road from Madang to Usino Junction (Ramu Highway) is of a lesser standard with steep vertical gradients and is less suitable for haulage of heavy equipment and goods.



Currently there is no sustainable, direct, all-weather road access to the Yandera site. It is planned that the mine access road from the Ramu Highway across the Ramu River Valley and from there further along the Imbrum River Valley past Bundi Village to Yandera will be constructed in several simultaneous construction packages.

The current road access to Yandera site is via a number of dirt tracks and is as follows:

- An existing access road between Usino Junction on the Ramu Highway and the Ramu NiCo Mine.
- An existing minor access road (gravel) between the Banu Bridge across the Ramu River (access to Ramu NiCo Mine) and Bundi Village.
- An existing minor access road (gravel) between Kundiawa on the Highlands Highway and Pandamai Junction.
- Existing dirt tracks between Pandamai Junction to both Yandera Village and Bundi Village via Snowpass.

Bulk earthworks and haul road construction in the mining area and access road construction that start from the Yandera side will require initial access via the Highlands Highway from Kundiawa and then northwards through Gembogl and Keglsugl in the Simbu Province. Some upgrading of the road between Keglsugl and Yandera will be required to allow road construction machinery to access the route for an interim period until the main access roads have been completed.

Road construction that starts from the Bundi Village area will proceed either westwards or eastwards along the Imbrum River Valley. A new road section is required between Bundi Village and Yandera whilst the section from Bundi Village eastwards towards the Ramu River Valley will be upgraded to a higher standard of road. Access to the start point of these contracts will be gained via the existing 4-wheel drive access track leading from the Ramu NiCo access road at the Banu Bridge over the Ramu River via Wau Village. Some upgrading of the road between Wau and Bundi Village will be required to allow road construction machinery to access the route.

Construction across the Ramu River floodplain will be started from both sides of the valley. Access to the northern end of this road section is gained directly from the Ramu Highway whilst access to the southern end of the road section is gained from the existing 4-wheel drive track that runs between Banu Bridge and Wau Village. Some upgrading of the road between the southern end of the Ramu River Valley road and Wau Village will also be required.

A new, permanent access road to the project site will thus be developed from the Ramu Highway across the Ramu River Valley via Wau and Bundi Villages to Yandera. The total route length of this section of road from Yandera to the Ramu Highway is approximately 50km. The design basis is noted in WorleyParsons Report: Yandera Project – Main Access Road Design Report., Ref. No. C00651- 4100-CI-REP-0001.

The base design criterion for the new access road has been determined as a 12% vertical gradient for an unlimited distance for the majority of the route but also providing a gradient not exceeding 15% for distances less than 150m. The latter constraint is determined by design requirements for the concentrate slurry pipeline that will be co-located in the access road corridor. This is to prevent settling out of the slurry into plugs at low points of the slurry pipeline in the event of pumping stopping for a period.





The horizontal curves are based on an average minimum criterion of 50m radii with an absolute minimum of 30m where required to minimise excessive amounts of bulk earthworks. Speed restrictions will be introduced at these horizontal curves. The maximum design speed is 40km/hr.

A new access road from the Ramu Highway (Walium Village) to the Yandera mine site of approximately 50km length is required to be built as a part of the Project through the Bismarck Mountain range. Approximately 39km of this road is a new road and the balance of 11km is a proposed upgrading of an existing 4-wheel drive track.

In addition to this road section, access is also required from the Ramu Highway to the Cape Rigny coastal area. Two separate reports were compiled to assess road access options to the two development zones of the Project located at Cape Rigny and at Yandera.

The first report, WorleyParsons Ref No. C00651-4000-CI-TEN-0001 was compiled to report on the findings and recommendations culminating from a trade-off study conducted between the construction options, estimated capital expenditure and operational costs associated with a proposed new coastal link road between the Ramu Highway and Cape Rigny in comparison to providing a barging facility from the Port of Madang to provide access for both the construction as well as the operational period of the Cape Rigny flotation plant and associated facilities.

The second report, WorleyParsons Ref. No. C00651-4100-CI-REP-0001, relates to the planning and design of the upgrading of sections of existing 4-wheel drive tracks and the construction of new sections of road to provide adequate road access between the Ramu Highway and the Yandera Project sites.



**Figure 18-7: Location of Proposed Cape Rigny Coastal Facilities**

Figure 18-7 shows the location of the proposed Cape Rigny coastal facilities and the existing 4-wheel drive access track from Cape Rigny to the Ramu Highway. The Ramu Highway is connected to the cities of Madang to the North and Lae in the east.



## 18.5 Rail Facilities

No rail facilities are available in PNG to support any parts of the Yandera mining project.

## 18.6 Air Transportation

International air traffic services into PNG arrive via Jackson Airport, Port Moresby.

All provincial capitals, inclusive of Madang, are serviced by Air Niugini, other airlines and by charter flights. Madang aerodrome has an asphalt runway 1,577m in length and 32m in width and can facilitate the operation of aircraft to Fokker 100 size on a 24-hour basis but customs, migration and quarantine facilities are not available. Airlines of Papua New Guinea (APNG) and Travel Air also service Madang.

Two gravel aircraft landing strips exist in close proximity to Yandera site. One is located at Bundi and the other at Keglsugl, 668-m and 692-m long respectively.

Currently, direct access to the Yandera area is via local PNG helicopter operators. This method of personnel access and smaller deliveries will likely continue until the site access road has been developed.

Helipads will be constructed at both the Yandera as well as at the Cape Rigny sites. Helicopter transport can be used to transfer personnel when the access roads or the barging services are out of service.

In addition, helicopter transport may be called upon from time to time for medical evacuations or visits to site.

## 18.7 Port Facilities

This section defines the port area facilities defined during the PFS. All material referenced in this Report appears in one of the attached documents produced during the course of this study:

- C00651-5000-CI-REP-0001 – Marine Facilities Site Selection.
- C00651-5000-CI-REP-0002 – Marine Terminal Conceptual Design.
- C00651-5200-CI-CRT-0001- Marine and Coastal Engineering Design Criteria.
- C00651-5200-CI-TEN-0001 – Marine Terminal Cost estimate and preliminary construction schedule.
- C00651-5000-CI-REP-0003 – Metocean data Review Report.
- C00651-5000-CI-REP-0004 – Wave Modelling Report.
- C00651-5000-CI-REP-0005 – Water Levels Assessment Report.
- C00651-5200-CI-TEN-0002 – Barging Study.



### 18.7.1 General Overview

The scope of the port facilities for the Project includes the receipt of concentrate delivered by an overland feed conveyor from the process plant to a storage shed at the rear of the quay to the load-out and shipment of the concentrate on Handymax vessels for export to international markets. Following a trade-off study which compared different sites for the location of the port with regards to environmental conditions (wind, waves, and currents), bathymetric and topographic conditions, navigation and safety aspects, operational constraints and environmental aspects, a site was selected for the installation of the port and associated handling infrastructure.

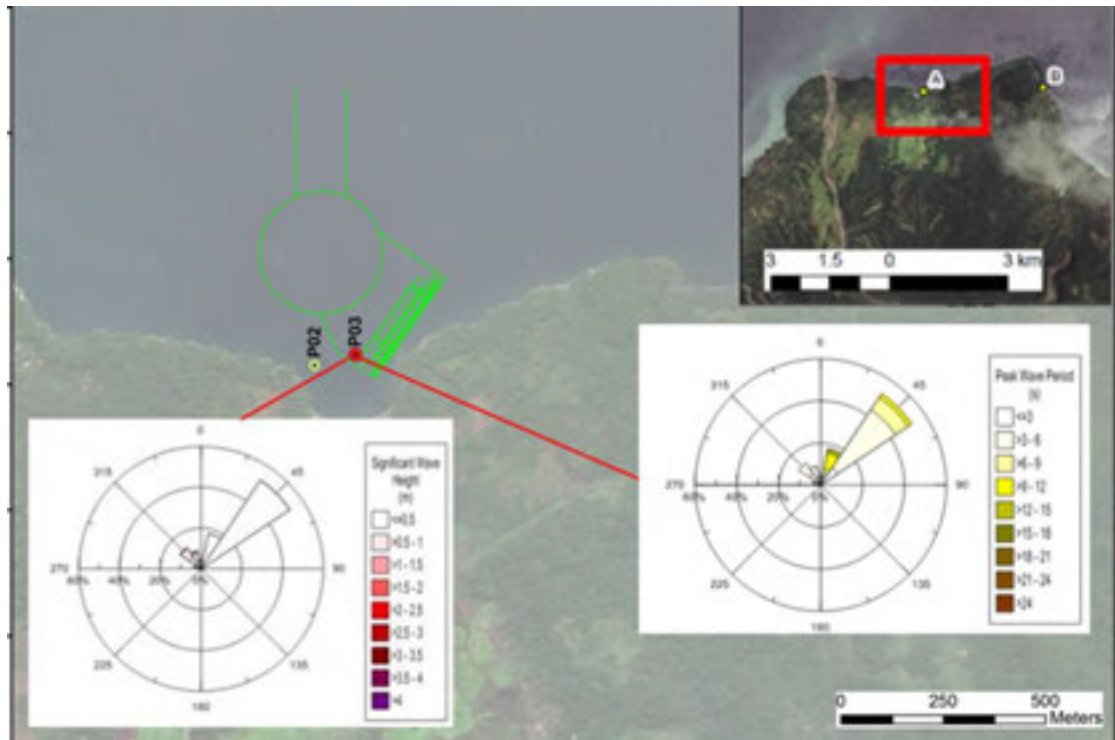
The selected site is located along the northwestern shore of Cape Rigny in a bay with a sandy bed and coral reefs along both eastern and western side. The bay is naturally sheltered from waves coming from the northeast.



**Figure 18-8: Photograph of the Preferred Site for the Port Infrastructure located along northwestern shore of Cape Rigny**

The proposed quay for the port consists of an open pile deck structure oriented on a north-east/south-west alignment in natural water depths of approximately 20m.

The quay is aligned with the predominant wave direction from northeast. The area behind the quay may need additional earthworks to access the quay deck to provide sufficient space for the installation of a shed for stockpiles. This area is to be protected using a rock revetment that will extend underneath the quay deck. Special attention will be taken during further stages of the design to account for potential future seismic action on handling equipment mounted on the top of the deck and at the rear of the quay.



**Figure 18-9: Proposed Site for the Port Installation and Wave Roses derived from the Wave Transformation Study**

Following a trade-off study, which compared different types of structural system for marine facilities a preferred option, was selected and developed further to the level of engineering consistent with the requirements of this project.

The following structural systems were investigated and compared in order to select the most appropriate one for the berth.

- Combi-wall, which is a retaining, structure formed by the combination of steel sheet pile and steel tubular piles. The resultant wall resists the soil and water pressures from the earth fill which forms the quay. The wall is also designed to resist the forces from the ship berthing and mooring and shiploader.
- Pre-cast pre-fabricated caisson, which are a gravity retaining structure that can be built offsite in concrete and floated to the site where it is installed in its final position. As with the sheet pile wall, the quay would be formed by the retaining structure (caisson) and the earth fill built at the rear of the caisson.
- Pile suspended deck, which consists of a concrete deck built on top of steel tubular piles driven to the soil. A concrete wall constructed on top of a rock revetment retains the reclamation/earth fill at the rear of the piled quay. The loads on the deck from berthing, mooring and shiploader operation are transferred directly to the piles. A typical section is shown below:







### 18.7.3 Port Implementation Strategy

The quay as presented above will be implemented in one stage only and need to be fully commissioned before the plant commences operation in order to cater for the Handymax vessels that will transport the concentrate from PNG to the consumer markets.

However, a pioneering structure consisting of a landing ramp installed at the natural beach near the quay site is proposed to allow for the offload of construction equipment, materials and personnel to the site before the quay is completed. Refer to document C00651-5200-CI-TEN-0002 -Barging Study for details of the proposed landing structure and logistic operation.

The port scope also includes some elements that need to be part of an early works strategy in order to allow for an adequate plan of the site construction. These are:

- Geotechnical offshore survey complementing the current one in order to provide sufficient data for the detail design.
- Construction of landing structure to allow for offloading of equipment and materials for the port and plant construction before the quay construction commences.
- Supply of marine equipment such as barges and tug boats for operation and construction.
- Supply of long lead items such as the shiploader and conveyors.

No specific modularization study was conducted as an alternative construction strategy for the marine facilities. However, the location for the quay is relatively sheltered, a natural beach to the south of that location could accommodate a landing facility supporting the construction, which suggests that a traditional “in-situ” construction will be adequate with minor or no offsite fabrication required apart from the mechanical equipment, and tubular steel pipes.

### 18.7.4 Marine Facilities Design Criteria

The design life for the new facilities shall be in general 50 years. Where it is impractical for elements of the facilities, provision will be made for replacement of such elements in the stay in business capital provisions.

#### 18.7.4.1 Quay and Berth Requirements

- The design rate is for 30Mtpa of mined ore, resulting in a concentrate production of 318,957tpa.
- Parcel size is set as 11,500tpm exported by one vessel every 13 days.
- A continuous quay with a single berth is considered sufficient for the planned throughput and required utilization of one vessel a month.
- The largest design vessel is a Handymax 50,000 DWT / 200m LOA / 33m Beam and 13m draft.
- Total berth length of at least 250m needs to be provided to safely cater for a Handymax 200m LOA.
- In order to provide sufficient deck area for the proposed mobile shiploader, a width of 30m is proposed. The deck surface will be flat and no rails or recesses are to be provided.





- The proposed manoeuvring area is exposed to northeasterly and northwesterly waves, as well as currents and winds. It is likely that tugs may be required to assist vessels during berthing. On this basis, the diameter of the turning circle is set to  $2 \times \text{LOA} = 400\text{m}$ .
- The piles will be driven into pre-drilled holes with diameters equal to 95% of the pipe OD. Five rows of piles will be necessary to provide support to the 30m deck. The following pile spacing has been assumed:
  - Longitudinal spacing : 6m
  - Transversal spacing : 6.25m
- Two longitudinal beams are placed at 25m running along the entire wharf at the location of the proposed ship loader rails. Transversal beams connect the front row of piles and the rear abutment. Beams can be either pre-cast or cast in-situ, depending on contractors' preferences. Precast slabs are placed between beams and a final in-situ topping slab is cast to ensure a robust connection between the structural elements. Cone fenders and bollards are installed at regular spacing along the front row of piles.
- An important consideration is that the port site is located in an area of potential seismic and tsunamigenic hazard; the proposed structural system will need to be able to resist the loadings caused by any potential ground motion as well as any potential tsunami waves with limited damage.

### 18.7.5 Port Facilities Layout

The proposed layout of the port facilities is presented in 3D rendering in Figure 18-11 and shows the concentrate stockpile, transfer conveyor and quay.



**Figure 18-11: 3D Rendering of Port Facility**



## 18.8 Barging Facilities

Barging has been selected as the preferred logistic solution to transport materials, equipment and personnel from Port of Madang to Cape Rigny site for both the construction period as well as for the operational period of the Project.

The proposed logistics operations will have to consider adequate maritime equipment and infrastructure to allow for the transport of all necessary construction materials and equipment to site during construction of the camp, port and plant as well as the personnel working in the construction and operations of those facilities. The operations shall continue after the start of the flotation plant operations allowing for the transport of the labour force working on the port and plant as well consumables and goods to support the plant operations and needs of the personnel staying at the camp. Thus, the logistic operations shall be able to start before the wharf construction commences and extends to the end of the life of the Project.

For the purpose of this study, a Ro-Ro (Roll-on/Roll-off) concept is envisaged for both loading and unloading facilities on the Port of Madang and at Cape Rigny; this concept assumes that a landing barge approaches the landing ramp and deploys a special heavy-duty steel portable ramp, which allows trucks and trailers to drive on and off the barge.

The proposed loading/unloading facilities comprise concrete paved ramps to allow for barges “beaching” while also allowing for tidal level fluctuation. This concept is ideally suitable for low budget quick erection of offloading facilities in Greenfield developments.

It is considered that a single Ro-Ro barge will be able to transport all required cargo in suitable time. Since each leg of a return cycle journey will take between three and four hours, depending on the barge speed and sea conditions, the barge could complete a full cycle back to its departure point during daylight within one shift. The benefit is that only one crew per vessel would be required.

It is assumed that both loading and unloading sites will be upgraded after the construction phase to become a permanent operation for the life of the Project. Notwithstanding the benefits of the Ro-Ro operation, the same barge can be utilized in a standard crane load/unload operation (Lo-Lo) after the wharf is fully or partially constructed.

The barge will have to provide for sufficient deck capacity to accommodate sufficient numbers of trucks, passengers and crew for the proposed logistics system. A landing barge type is selected to permit Ro-Ro operations utilizing landing ramps to be constructed on both loading and unloading sites.

The list below presents the basic requirements for the proposed barge:

- Suitable deck loading or TCP (tonnes per centimeter) to cater for 60t semi-trailer trucks.
- Power units aft and forward located not too close to the bow and stern of the barge allowing for beaching to the ramp.
- Capable of sailing safely on the met-ocean conditions of the area although for safety purposes a coastal route was selected.
- Accommodation for the crew in case the barge need to stay in Cape Rigny due to bad weather or operational constraints where there wouldn't be any camp facilities during early works phase.



- Crew of Master, Engineer, Load Master and three Deck Persons.
- Cargo to be secured appropriately.

For this study, an example of the proposed barge is “Teras Bandicoot” LOA 54m / B18m / H4.5m / D3m. For the landing, passenger boat a 12-seater high-speed boat is selected.



**Figure 18-12: Photo of the Proposed Landing Barge**



**Figure 18-13: Rendered Image of the Proposed Landing Passenger Boat**



**Figure 18-14: Proposed Barging Route between the Port of Madang and Cape Rigny**

Further detail of the barging system is provided in document number C00651-4000-CI-TEN-0001, titled Coastal Road vs. Continuous Barging Operations Trade-off Study.

## 18.9 Project Facilities and Utilities

This section provides a description of the local infrastructure required at the mine site and coastal facilities to support mining and processing operations.

### 18.9.1 Change Houses

Change house facilities will be provided at the Mine Precinct and the Coastal Facilities as well as the camps. The change house infrastructure will be capable of accommodating all the people for initial construction and steady state operations.

### 18.9.2 Office Accommodation

The mine administration offices will be located at the Mine Precinct and at the Coastal Facilities. The office building at the Mine Precinct will house the mine and process plant management and shared services personnel.

### 18.9.3 Accommodation Camps

Temporary construction camps and laydown areas will be established at Yandera and at the Coastal Facilities. At Yandera, the existing exploration camp will be used for this purpose, whilst the early works and construction activities take place. The permanent Yandera camp is planned on a property just north of the Mine Precinct area near Yandera Village. A similar camp facility is planned at the coastal facilities location.



## 18.9.4 Fuel and Lubrication Offloading and Storage Facilities

Fuel and lubricants will be delivered to the mine by delivery trucks or tankers. Fuel and lubrication offloading and storage facilities are provided for at the Mine Precinct. These facilities will be suitably isolated from nearby infrastructure and suitably ventilated. The storage containers will be banded to prevent fuel contamination. Considering the ramp-up period, the size of the mining fleet and the associated diesel consumption provision is made in the planning for a diesel transfer facility in the Banu Valley from where the diesel could be pumped up to Mine Precinct. If feasible, the capital for such a system could be provided for later on in the life of the mine.

## 18.9.5 Fire Protection Facilities

Fire pump stations will be provided as part of the main infrastructure at the Cape Rigny and at the Mine Precinct. Provision has been made for a combined storage tank for raw and fire water at each project area. The tank will be designed such that a minimum level is maintained at all times sufficient to provide the required volume of firewater. Each fire pump station will be equipped with a primary electrical pump and a secondary diesel pump if power is not available.

Adequate fire ringmains will be installed within the Mine Precinct and the coastal facilities to meet the minimum requirements for a fire protection system. Fire hydrants and hose reels will be connected to the ringmains.

Fire extinguishers will be located around the mine where water is either not suitable for fire extinguishing or simply not available. Portable fire extinguishers will be positioned at the entrance of each building.

The sizing of the fire main and the water pressure, required within each section of the system will be adequately designed to meet the minimum requirements of the applicable code/regulation, for all of the fire protection systems installed.

A firewater ring main system will be provided for the Mine Precinct and coastal facility footprint. The ring main will be buried and divided into sections by accessible isolation valves so that any damage to one section of the ring main will not compromise the fire-fighting capability of the entire system. Below ground, section of the fire water mains should be run in HDPE piping and the aboveground fire water mains piping will be carbon steel piping.

## 18.9.6 Communication Systems

The communication network will consist of the following:

- Telecommunications network.
- IT Network.
- Control Network.
- Radio Network.
- Satellite communications.

Telecommunications network will consist of an external supplier providing a data link to site. On site data network will be fibre network interconnecting complete infrastructure with redundancy capabilities.





The control system with centralized control, SCADA and HMI interfaces will be connected via fibre network for the entire operation.

The BRASS Engineering scope of work includes for the installation of a fibre optic cable alongside the overland slurry pipeline (146km-long) running between the mine site and Cape Rigny. The telecommunications system design is based on a fibre optic “backbone,” which carries all communications, including SCADA, voice, office data and video.

A radio network will also be available in each location for site communications and operational staff.

### **18.9.7 Waste Management Facilities**

Operational and domestic waste handling facilities will be provided at the Mine Precinct and the coastal facility where administrative and operational activities are to be conducted.

The following waste handling will be provided for, at both the Mine Precinct and at Cape Rigny:

- General domestic waste such as produced by the offices will be separated into organics and recyclables (Metals, plastics, glass, paper etc.).
- Hazardous storage areas for hazardous waste requirements such as, batteries, lubricants, and other hazardous substances will be provided for and be disposed of by an accredited service provider.
- Medical waste disposal facilities would be provided for each of the Medical stations. From the Medical station, the medical waste will be collected and disposed of by an accredited service provider.

### **18.9.8 Other Facilities provided at Mine Precinct**

- Electrical distribution substation.
- Emergency and standby power generation facility.
- Ore and waste handling systems.
- Run of mine stockpile.
- Heavy vehicle and light vehicle workshops and refuelling facilities.
- Access control, security, stores and warehousing.
- Control room and medical station.
- Open air storage areas.
- Potable water treatment plant and storage tank.
- Raw water tank and process water pond.
- Sewage treatment works.
- Storm water management and diversion systems.
- Parking areas and service roads.
- Material (aggregate) supply quarry including crushing and screening plant.
- Explosives magazines.





- Sedimentation control ponds.
- Helipad.

### **18.9.9 Other Facilities provided at Cape Rigny Coastal Facilities**

- Electrical distribution substation.
- Emergency and standby power generation facility.
- Light vehicle workshops and refuelling facilities.
- Access control, security, stores and warehousing.
- Control room and medical station.
- Open air storage areas.
- Potable water treatment plant and storage tank.
- Raw water tank and process water pond.
- Sewage treatment works.
- Storm water management and diversion systems.
- Parking areas and service roads.
- Material (aggregate) supply quarry including crushing and screening plant.
- Sedimentation control ponds.
- Helipad.

### **18.10 Mine Pit Infrastructure and Logistics**

The Pit infrastructure consists of:

- The roadways and haulage roads connecting the Mine Precinct with the Pit areas.
- Electrical reticulation to support the mining operation.
- Storm water control systems.
- Pit dewatering systems.

To support the planned production rate, diesel-powered mobile mining equipment is deployed. The mine pit areas are connected to the Mine Precinct via haul roads and these haul roads will give access to all areas for logistical support. The pit logistics will include the support of the following:

- Ore and waste rock handling.
- Personnel transport.
- Emulsion and explosives.
- Field maintenance and support.
- Consumables delivered to work areas.
- Water and dewatering.
- Lubrication and fuel to work areas.



Materials, equipment and consumables for the Pit areas are supplied via the Main Warehouse at the Mine and Milling Precinct.

### **18.10.1 Ore and Waste Rock Handling Systems**

- A fleet smaller than the mining fleet consisting of hydraulic excavators and dump trucks will be used for the local road construction.
- The in-pit infrastructure for rock handling will comprise electric rope shovels with a bucket capacity of 50.8m<sup>3</sup> and a nominal payload of 81.6t. The rope shovels will load fragmented rock into electric dump trucks with a dump box capacity of 218m<sup>3</sup> and a nominal capacity of 360t. The dump trucks will haul the broken rock to either the RoM tip area for crushing ahead of the processing plant or the waste rock dump.

### **18.10.2 Equipment**

- The mining equipment will be sized and selected based on the suitability for opencast mining application.
- Operational equipment will be equipped with engines utilizing technology to optimize efficiency and to minimize emissions.
- Collision avoidance and people detection devices will be fitted to all mobile mining equipment.
- Steering and brake interlocking safety systems, on-board fire suppression systems and engine protection systems will be standard features.

### **18.10.3 People**

Employees working in pit areas will, at shift changeover, be transported from the Mine and Milling Precinct by means of dedicated personnel carriers or light vehicles from designated pick-up points.

### **18.10.4 Explosives**

Explosives for development and production will be of the emulsion type.

The manufacturer to the bulk silos on surface will deliver emulsion. From the bulk silos, emulsion will be loaded into emulsion cassettes for delivery to pit areas as required. Blast holes will be charged using emulsion charging vehicles.

The supplier will be responsible for delivery of explosive accessories to the designated places on surface. Explosive accessories will be delivered to the Pit areas explosive storage boxes using the appropriate explosive transport vehicles.



## 18.11 Dumps and Stockpiles

### 18.11.1 Waste Rock Dump Design

The waste rock dump was designed as an engineered un-compacted and unclassified valley infill structure. The waste rock dump is designed with an overall slope angle of 18°. The configuration of the front face has a 1:3 face slope, 50-m high with a 100-m wide bench. Taking the material properties, seismic loading and drainage under the structure into account, the structure has an overall factor of safety of above 1.

The design of the waste rock dump includes an engineered underdrain that consists of classified boulders, sourced from the streams and the mining area or from material obtained from the Mt Wireless Quarry. The underdrain is covered by a geomembrane to allow runoff from the gullies on the mountain slopes on the sides of the waste rock dump and the catchment area behind the dump to flow underneath the dump and not be contaminated by acid drainage emanating from the dump. This will also limit the erosion to the waste rock dump resulting from expected heavy rainfall incidents. Downstream from the dump sediment traps and water handling facilities will be provided to mitigate against pollution and the impact of any potential acid drainage.

The top of the dump will be “whale backed” to prevent ponding of water on the top surface of the dump as much as is practically possible. The final top surface of the dump will be compacted and protected against erosion. Provision is made for the construction of a permanent storm water overflow drain system along both sides of the WRD. The purpose of these drains is to convey and discharge any major floods in a controlled way across the top of the WRD without serious damage or possible wash-away of the dump.

Based on the sulphide concentrations in the waste, approximately 50% of the waste generated is considered potentially acid forming (PAF) and needs to be handled as such. A total of approximately 170mm<sup>3</sup> (solid volume) of PAF material will need to be accommodated in the waste rock dump. Clayey material suitable for use as a clay liner below and above the PA material to encapsulate it within the dump is not readily available in the mining area in the required quantities. Consequently, an alternative approach will be followed whereby crushed limestone will be used as reagent to neutralize the acid forming potential of this waste type. Based on the production schedule and in-situ material properties, cells will be prepared within the WRD by lining the cells with a layer of crusher dust, sourced from the limestone quarry. The cells will each be capped with low permeability material sourced from the mining footprint.

The Mogoro Creek as well as the Yewago River Valley areas within the WRD footprint is planned to be used as medium- to long-term stockpile area for below grade or oxide materials that cannot immediately be processed economically. The dumping or temporary stockpiling in these areas will be handled exactly in the same way as for the permanent dump but these areas will be reclaimed following the re-mining of the stockpiled materials at a future date.

### 18.11.2 Stockpiling of Ore

The mined out South 2 pit will be used as an operational stockpile to place ore when the processing plant cannot accommodate the mined ore.



The same area will be used as a short-term operational stockpile for sulphide material while batch processing oxide ore. The stockpiling capacity of this area is estimated at  $\pm 2$ Mt. The South 2 pit stockpile will be mainly contained within the pit excavation, which should limit environmental impacts.

The surplus oxide ore, and the below cut-off sulphide ore will be stockpiled on separate areas allocated within the oxide stockpile area in the WRD; as oxide ore is continuously consumed during the LoM, the Mogoro Creek will be used as the oxide stockpile. The Yewago valley will mainly consist of below cut-off sulphide ore stockpile of up to  $\pm 70$ Mt before being re-handled with mining equipment and processed during the last five years of the LoM.

The oxide stockpile volumes are dependent on the final metallurgical test results, which will determine the ore treatment philosophy and could have an impact on the final WRD volumes in the FS.

A coarse ore stockpile is provided to accommodate the difference in crushing and milling rates, and to provide a continuous feed to the mills. This stockpile is situated local to the mills and is described in Section 17.

## 18.12 Tailings Disposal

The tailings from the flotation plant will be placed undersea with Deep Sea Tailings Placement (DSTP) system. The system mixes the tailings with seawater in a ratio about 1:1 in mixing tanks on shore, then discharges the diluted tailings slurry through outfall pipelines to depth of 210m, below both the ocean mixing zone where wind and waves promote fluid mixing, and below the biologically active zone.

The downward seafloor slope at the tailings discharge point is about 40%, which promotes the creation of a density current carrying the tailings to great depths. Ultimately, the tailings are deposited on the ocean floor in Vitiaz Basin with depth about 1,000m much as sediment from nearby rivers would be deposited.

The DSTP system is designed following SAM's Guidelines for Deep-Sea Tailings Placement. The system is composed of three parallel series, two operating and one spare. Each series includes an 8m (D) by 9m (H) mixing tank with a seawater pump, a 72-m long HDPE seawater intake pipeline and a 798-m long HDPE outfall pipeline. The wall thickness of the HDPE is 83mm, which provides adequate strength to withstand high stress during pipeline installation and wear allowance for tailings transport.

The outfall pipeline route is chosen to minimize the traverse slope and, hence, minimize any rolling or sliding tendency of the pipe. The location of the terminus is chosen to prevent any accumulation of tailings near the outfall.

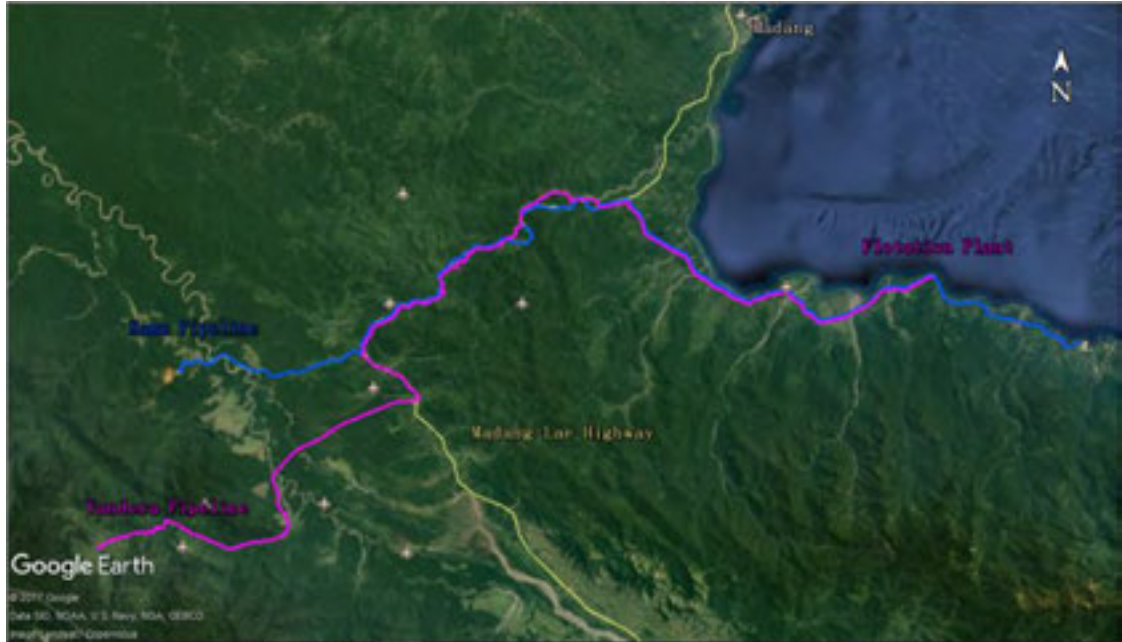
The DSTP operation is driven by gravity in most cases. The seawater pump will be operated only when the outfall pipeline needs to be flushed with water. The current design will utilize the flotation plant DCS system to operate the DSTP. Tank level and density sensors will be connected to the DCS to establish the shut down and start-up control mechanism of the DSTP. The Pipeline Expert™ software for leak/plug detection will be installed in a dedicated computer next to the DCS computer.

For more detailed information, refer to Deep Sea Tailings Placement Pre-Feasibility Study Report (BRASS Ref. No. BBL 010.9-B-DC 002).



## 18.13 Ore Slurry Transfer System

The ore ground in the Yandera mill will be transported by pipeline in slurry form to the flotation plant at Cape Rigny. The total length of the pipeline will be approximately 146km. The pipeline will be laid along the new mine access road and existing public road. Figure 18-15 shows the proposed pipeline route and roads.

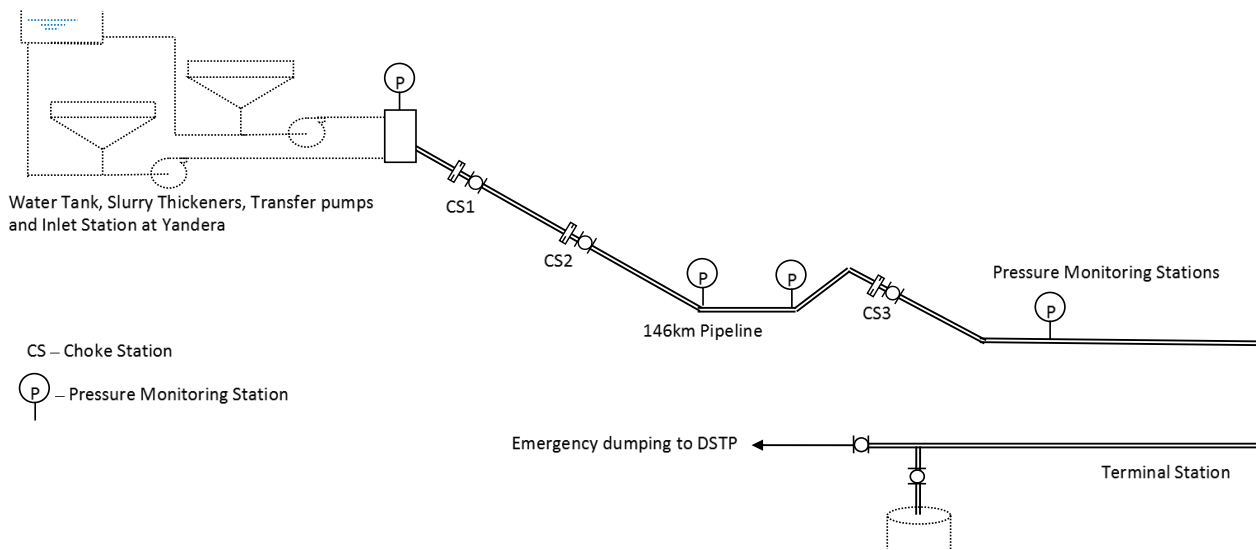


**Figure 18-15: Proposed Route of the Slurry Pipeline from the Yandera to Cape Rigny**

The pipeline flow will be driven by gravity from elevation of 1538m at the Inlet Station to 30m at Terminal Station. There will be three intermediate choke stations to control the pipeline flow rate and limit the spill in case that the pipeline leaks. As shown in Figure 18-16 the pipeline system also includes four pressure-monitoring stations for leak detection. Communications between the stations will be through a fibre optic cable and will be backed up with a satellite channel.

The annual throughput of the pipeline will be 30Mt of ore. The nominal flow rate is 4500m<sup>3</sup>/h with solids concentration of 55%. In the early years of operation, the mine production will be lower than the design capacity. The flow rate can be reduced to 4000m<sup>3</sup>/h by engaging more chokes at the choke stations.

The solids concentration will also be lower. The concentration is controlled by the balance of the thickener feed and discharge. When the solids fed to the thickeners are less than the solids discharged, the mud bed level will drop, the discharge concentration will decrease until the solids feed and solids discharge become balanced. The minimum concentration is defined to be 50%, but can be lower if necessary.



**Figure 18-16: Pipeline System Schematic**

The pipeline outside diameter will be 34 inches. API 5L X65 specification steel pipe is selected for the Project based on the successful applications of this material on other similar slurry pipelines. The average pipe wall thickness is 15.9mm. In high-pressure sections, 17.5mm will be used to increase pipeline pressure capacity. In lower pressure sections, 14.3mm will be used to save cost. The pipes will be coated with 3PE to prevent external corrosion. The pipeline will also be protected with a cathodic protection system.

Supervisory Control and Data Acquisition (SCADA) system will be used for pipeline operation. The Human-Machine Interface (“HMI”) workstations will be located in the mill control room, which can control the entire pipeline systems remotely. Pipeline Expert™ software will be installed in the workstations to detect any abnormal operating conditions, such as pipeline leak, plug, slack flow or over-pressure. Advisory notice and warning will be shown on the HMI screen. An alarm will sound if a serious incident is detected.

In case of pipeline rupture at a weld or other pipe weakness, repair kits with the necessary excavation and other equipment to make immediate repairs will be pre-positioned at the choke stations. Practices that have been developed and proven in the petroleum industry for making repairs in a very short time period will be used for the Yandera pipeline. Emergency repair crews will be trained and available for urgent repairs if ever necessary.

For more detailed information, refer to Ore Slurry Pipeline Pre-Feasibility Study Report (BRASS Ref. No. BBL 010.9-B-DC 001).

## 18.14 Water Facilities

The bulk water supply would be obtained from the streams and rivers affected by the project footprint and from the water extracted during pit dewatering process. The annual average rainfall at Yandera is around 5,000mm and the process, industrial, determines bulk water supply quantities and potable water needs and the demand of water required for slurry transfer in the pipeline to Cape Rigny.





### 18.14.1 Bulk Water Source

Bulk water supply would be sourced from the surrounding rivers and include the following:

- Tai-Yor river, Yewago and Dengru rivers.
- Mogoro creek.
- Imbrum river.

Raw water would be harvested from the sedimentation pond, after downstream of the WRD and will be pumped to the Mine Precinct. The water will be accepted in the process water circuit and excess water overflow if present will need to be treated to World Health Organization standards, before releasing back into the natural water system.

In the assessment of the aforementioned available sources, it became clear that there are risks related to the sustainability for supplying the required volumes to the Yandera mine and the existing Yandera Village. It is therefore proposed that during the 1-in-5-year drought period, water could also be extracted from the following sources to supplement the shortfall of water.

- Use water storage facilities constructed as part of the mine development (for example, temporary water storage up-catchment from the WRD).
- Withdraw water from the Imbrum River, which passes close to the northern end of the main mine pit area (and to the south of the North Pit).
- Extract water from the lower reaches of the Tai-Yor River where tributary streams supplement the flowrate of the Tai-Yor River.

### 18.14.2 Storm and Contaminated Water

Storm water is defined either as the natural water that enters the mine area during a rainfall event, by direct rain on areas in the mining area or as collected storm water from outside the mining area.

Contaminated water is all water that is chemically contaminated due to mining operations and has to remain within the closed loop water balance internal to the mining area. Typical sources are rainwater falling on contaminated or exposed acid forming geological structures, dirty areas, spillage water and seepage through WRD.

The storm water management measures will, where necessary, include cut-off berms to divert storm water runoff upstream of the mining and plant areas.

The contaminated water management measures include the following features:

- Runoff collection drains local to the process and milling plants and wharf areas to collect polluted water.
- Dedicated contaminated water drainage systems around the stockpile areas.
- Pollution control dams to capture and return possibly polluted water to the process water circuits.
- Sedimentation ponds and water treatment facilities.



### 18.14.3 Water Management and Dewatering Systems

The water management would apply to water obtained from the streams and rivers affected by the project footprint and to the water extracted during the pit dewatering process. The annual average rainfall at Yandera is around 5,000mm and the runoff water from the catchment area needs to be captured and fed into the bulk water supply circuit.

During the early stages of mine pit development, the pit dewatering will be by mobile diesel driven pumps. The balance of service water will be raw water, harvested from the sedimentation pond, downstream of the WRD and will be pumped to the Mine Precinct. The water will be accepted in the process water circuit and excess water overflow if present will need to be treated to World Health Organisation standards, before releasing back into the natural water system.

As the pit development progresses and the pump delivery head increase, intermediate electrically driven pump stations are planned. Once the pump columns exit the mine pits the layout allows mainly for gravity flow of water to the mine precinct. Water is accepted into the process water circuit at the precinct and the majority of the water is used in the slurry transfer system to Cape Rigny.



## 19 Market Studies and Contracts

### 19.1 Introduction

The study team leveraged off market studies performed by Wood Mackenzie for this section of the report. Other reputable analysts, market reports, published articles and the study team's industry experience were used to substantiate or adjust certain rates or forecasts where relevant.

Global copper supply has been a topical market discussion in recent months as mine output, after disruptions, is expected to shrink for the first time since 2011. The reduced supply will however be offset by concentrate, blister inventories, and higher scrap consumption at both smelters and refineries. The increase in scrap availability in 2017 materialised due to higher than anticipated commodity prices.

2017's copper market is expected to remain in balance, with stocks drawn down slightly to 74 days of consumption. Supply disruptions for the year stand at approximately 530kt, which is higher than average analyst expectations; major disruptions took place at Escondida, Grasberg and Cerro Verde. These disruptions lifted the 2017 copper price to a 2½-year high of USD3.23/lb. The increased price was also driven by optimism in the Chinese economy.

A wave of projects is expected to hit the market in 2018 and 2019, such as Escondida, Toquepala, and Kamoto restart, Mopani, Cobre Panama, Sentinel and Bystrinskoe. The volumes from these expansions will most likely not result in a material change in cathode inventory levels over the next several years.

A strong recovery in copper prices is expected beyond 2020 and could provide much needed confidence for producers to undertake incremental expansions, mine life extensions and greenfield projects (refer to Table 19-1: Wood Mackenzie Copper Price Forecast (USD /lb) – June 2017). The long lead times required to bring new capacity into production means that there could be a period of consistent supply deficits between 2021 and 2024. Wood Mackenzie predicts that surpluses should start to emerge from 2025 onwards, once new supply starts to reach the market. Prices will then revert to a long-term average copper price of USD3.30/lb.

The above-mentioned market trends show that producers, who were willing to invest in the downturn, could benefit from the expected upswing and outperform their peers that are behind in developing projects.

### 19.2 Industry Outlook – Supply

Wood Mackenzie's research showed that abundant scrap has emerged in 2017 due to higher than anticipated copper prices. Global mine production expanded by 5.0% during 2016 reaching 20.1Mt. This increase compares with a 3.8% rise seen in 2015. 2017 mine production will fall for the first time since 2011; down by just over 2% on 2016 levels. This reflects the announcement of lower production guidance by some producers and a focus on 'profitable tonnes' over 'volume'.

Supply additions in Wood Mackenzie's production forecast include, Cobre Panama (+320kt/a), Escondida 3rd Mill (+250kt/a), Las Bambas (+100kt/a), Sentinel (+135kt/a), Toquepala Expansion (+100kt/a) and Aktogay (+80kt/a).



The forecast also includes highly probable projects such as Chuquicamata Underground (350kt/a), Oyu Tolgoi Expansion (500kt/a), Metalkol (75kt/a), Bystrinkoye (70kt/a), Magistral (30kt/a) and Kinsenda (20kt/a). In addition, Glencore's Kamoto Restart (+365kt/a) and Mopani (+100kt/a) is expected to re-start. Collectively, these will have a significant influence on the copper market during 2018 and 2019, pushing growth in mine supply back into positive territory.

Growth is expected to continue until 2020 and will see global production exceed 21Mt for the first time by 2018. However, beyond 2020, copper mine production growth will decline unless new or expanded capacity is brought into production. Given the long lead times to bring new capacity "online", producers should be positioning themselves now for the anticipated recovery.

Analysts believe that even without any growth in global demand, the market still requires more supply, particularly given the reduction in average global ore grades. Despite various mining companies seeing improvements in their balance sheets, investor appetite for miners to take on large capital projects remains low. Many of the next generation of projects are geographically more remote, with limited access to power and water. Soft issues are also becoming more prominent and prospective developers have to comply with increased expectations of local stakeholders. The combination of these challenges, along with lower grades mean that many projects will have to be larger than before to achieve economies of scale, requiring high capital investment. It is likely that those partnerships, joint ventures and M&A activities will support development of the additional supply requirement. This is not new to the sector with Japanese and Chinese firms historically co-investing in world class assets.

### 19.3 Industry Outlook – Demand

Global refined copper demand is projected to grow by 1.7% in 2017, which will increase refined consumption to 22.8Mt. Chinese performance within various end-use markets has been strong since the beginning of 2017 with the housing and appliance sectors particularly resilient.

The global refined demand is expected to continue along a moderate growth path up to 2021, averaging at 1.8% per annum. In the longer term, up to 2035, refined consumption is expected to grow by 1.2% per annum. This is in line with the 2000 to 2015 average of 2.8% and reflects analyst expectations that the emergence of China as a global economic force and driver of copper demand will not be replicated by any other nation for the near future. The growth rate for the China is however expected to decline in future.

The rest of the world is expected to contribute stronger performance than that seen over the past 15 years, and is expected to grow by 1.6% per annum, up to 2035. India and the ASEAN member states are expected drive the majority of future demand, fuelled by ongoing economic growth, urbanisation and associated infrastructure development.

The outlook for India is positive, even though they faced short-term demonstration disruptions. Long-term consumption drivers, which include urbanisation, electricity consumption and infrastructure development, will lift demand across all key end-use sectors. The total Indian consumption is expected to rise from 878kt in 2016 to 1.6Mt in 2025. Indian consumption is forecast to reach over 3Mt in 2035, representing around 8% of global demand, compared to 3% currently.

In addition, electric vehicles and associated distribution systems are expected to increase the demand for copper (UBS) forecasted that electric vehicles could increase the copper demand by more than 2% in 2025.



## 19.4 Supply and Demand Balance

Analysts indicate that significant supplies from un-committed projects are required post-2020. The lack of advanced-phase projects will lead to a tight metal market in the next decade. Figure 19-1 shows the long-term supply-demand balance and indicates the possible supply shortfall post 2020.

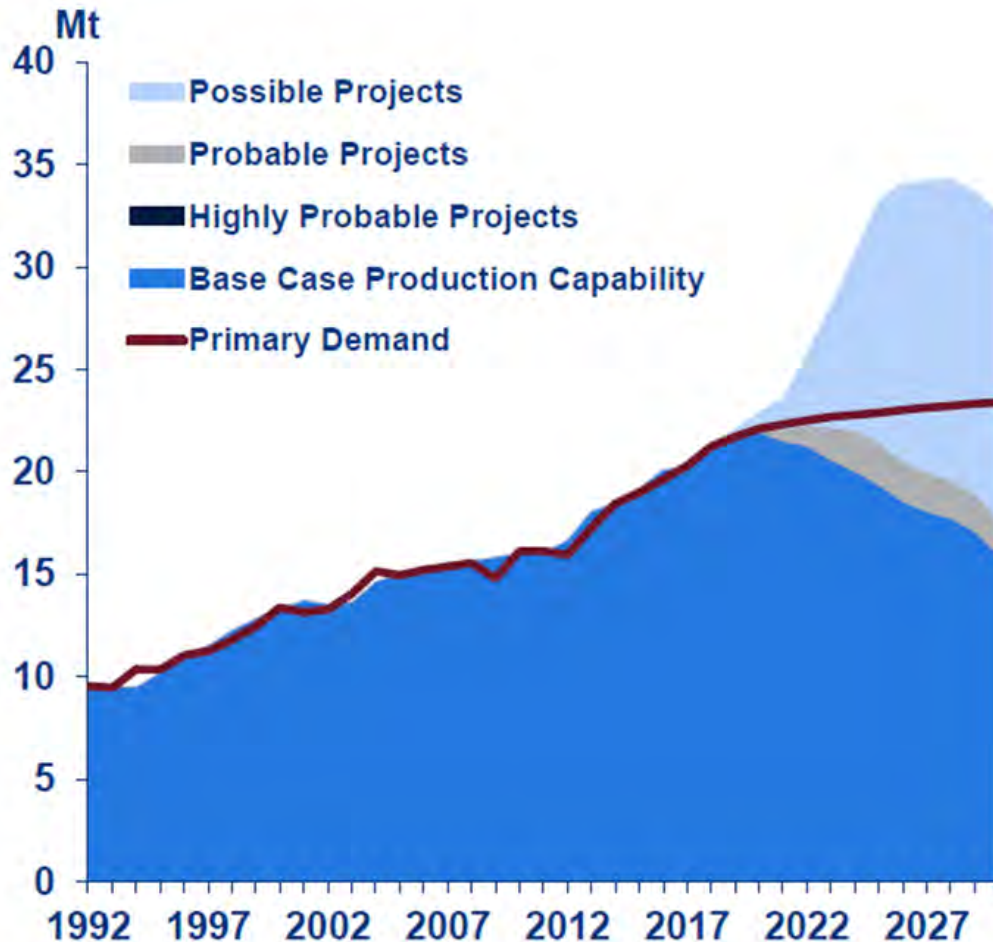


Figure 19-1: Supply-demand Balance (Source: Wood Mackenzie)

Although the graph indicates a possible shortfall, Wood Mackenzie predicts that post-2026 supply-demand balances and price forecasts will revert to trend levels, with additional mine production assumed to come “online” over and above what is available from their base case scenario.

Without the commitment to further investment in additional copper production capacity, the possible supply gap will amount to 4.5Mt by 2027. The long-term copper price of USD3.30/lb (real) will be sufficient to bring on adequate mine output to satisfy market requirements.



## 19.5 Copper Industry Threats and Opportunities

Uplift in the copper industry is expected, which will be driven by continued rapid urbanisation, electricity consumption and infrastructure development. Numerous influencing factors could however alter the copper demand and commodity price, such as:

### 19.5.1 Threats

- Substitution for copper cable by aluminium alloy cable could create uncertainty in demand.
- Concern about the underlying health of the Chinese economy.
- Ongoing supply disruptions.
- Lack of access to capital could delay project approvals and implementation. Late implementation could result in missing the higher copper price forecast between 2022 – 2025.

### 19.5.2 Opportunities

Long-term copper prices might increase over time due to the demand posed by the electrical vehicle industry.

## 19.6 Commodity Price Forecast

### 19.6.1 Copper Price

The real copper price forecast is displayed in Table 19-1.

**Table 19-1: Wood Mackenzie Copper Price Forecast (USD /lb) – June 2017**

	2018	2019	2020	2021	2022	2023	2024	2025	2026
USD/lb	2.60	2.65	2.85	3.15	3.50	3.75	3.9	3.65	3.30

The 2026 copper price will remain constant, in real terms, from 2026 onwards.

### 19.6.2 Gold Price

Gold is a financial asset class and currency markets, returns and dividends from equity investments, and bond yields influence its trading value. It is expected that gold will average between USD1,100/oz and USD1,400/oz over the next five years.

For the gold price to break out of its current range there would need to be substantial systematic risk entering the global financial system, preceded by either a major geopolitical event or a sustained slide in the economic performances of China, the EU and US. A long-term average of USD1,300 /oz was therefore selected for purposes of this study. The spot price at the time when this Report was drafted was USD1,335.90/oz and indicates that the selected rate is not unreasonable.





### 19.6.3 Molybdenum Price

It is expected that the concentrate will contain 50% molybdenum disulphide, or molybdenite ( $\text{MoS}_2$ ). The concentrate will have to be roasted, to obtain a marketable molybdenum trioxide ( $\text{MoO}_3$ ).

Molybdenum prices have fluctuated widely over the past years and ranged between USD5/lb to above USD43/lb. This reflects the cyclical nature of metal prices. Molybdenum is sold mainly through long-term contracts and suppliers generally attempt to negotiate and sign during favourable periods.

Analysts believe that the underlying long-term fundamentals of molybdenum remain positive. Molybdenum demand is expected to rise in the coming years as the BRIC countries (Brazil, Russia, India and China) continue to urbanise and adopt technologies that are more advanced. The rapid urbanisation will demand more “superalloys” and other high-performance steels, of which molybdenum is used in. In addition, molybdenum is in a strong position to strengthen as the energy sector expands. Molybdenum prices are expected to remain volatile and will be influenced by demand from China, emerging markets, and economic activity in the U.S.

The lack of new projects is expected to restrict supply, together with short-term disruptions. There is a very small project pipeline and the lack of projects is indicative of the deferral, downsizing and suspension of new mines brought about by lower historic copper and molybdenum prices. The result is that global mine production is forecast to grow by less than 1% per annum, which could increase the medium- to long-term commodity price.

Molybdenum elicited considerable optimism during the NiCoMo conference held in March 2017. During this conference, a molybdenum panel discussion revealed a consensus for strengthening demand. One of the attending companies forecasted more than 40% growth in consumption over the next five years. A recent increase in prices have also been noted, which was caused by tightening availability of material.

In the light of the above, a real long-term molybdenum price of USD13.30/lb was applied in the financial valuation model. A payability rate of 85% was applied in the valuation model. This rate includes roasting of molybdenum disulphide to obtain technical molybdenum ( $\text{MoO}_3$ ).

## 19.7 Realization Charges

Revenue realisation charges consist of the following:

- Copper deductions.
- Gold deductions.
- Copper treatment costs.
- Copper refining costs.
- Concentrate handling charges.
- Weight franchise deductions.
- Royalties and mining levies.



It should be noted that treatment and refining charges are negotiated on an annual basis, and differs for each mine. These charges and offtake agreements will be negotiated closer to the end of the Feasibility study. It is not expected that a variation in these estimates will materially misstate the project valuation.

### 19.7.1 Copper Deductions

Copper deductions are calculated by multiplying the copper revenue by the maximum of:

- 1% of copper in concentrate; or
- Copper payable scale

The payable scale for copper concentrate is shown in Table 19-2.

**Table 19-2: Copper Payable Scale**

Copper in Concentrate	Payable Scale
26%	96.15%
27%	96.30%
28%	96.43%
29%	96.55%
30%	96.65%
33%	96.65%
35%	96.65%
40%	96.65%

### 19.7.2 Gold Deductions

Gold deductions are calculated by applying a gold payable scale is shown in Table 19-3.

**Table 19-3: Gold Payable Scale**

Gold in Concentrate (g/tonne)	Payable Scale
1	0.00%
3	90.00%
5	95.00%
10	96.00%
20	97.00%
30	97.25%
40	97.50%
50	98.00%
75	98.25%



### **19.7.3 Copper Treatment and Refining Costs**

A real treatment cost of USD80 per concentrate tonne was used in the financial model, whilst refining costs of USD0.08 /lb was applied.

### **19.7.4 Concentrate Handling Charges**

Treatment and refining cost rates are based on CIF terms. An ocean freight charge of USD 25.75 /wmt copper concentrate was applied in the financial model. A shipping rate of USD 105 /wmt for molybdenum concentrate was applied in the financial model.

### **19.7.5 Weight Franchise Deductions**

Bill of loading costs (weight franchise deductions) was at a rate of 0.25% of total revenue.

### **19.7.6 Royalties and Mining Levies**

PNG's Mining (Royalties) Act of 1992 states that royalties are payable at a rate of 2% of net revenue.

PNG's Mineral Resources Authority act states that a production levy of 0.25% of net revenue is payable by miners. Government have proposed that the rate should be doubled, but mining companies that already operate in the country oppose it. Some mining companies argue that an increase in the rate will make investment in the country less attractive and it is therefore expected that this rate will remain unchanged.

## **19.8 Market Strategy and Product Characteristics**

The Yandera Project will develop a new and long-term copper resource that can supply both copper and molybdenum concentrates to world markets and thereby creating a platform for economic growth in Papua New Guinea. The project will have direct access to Asian markets as it is in relative proximity to Chinese ports from Madang. There is a possibility to supply smelters globally.

The copper and molybdenum concentrates produced at Yandera is expected to be marketable and to have average to above average copper concentrate grades, low impurities, and payable precious metal credits.

A detailed market entry strategy will be developed during the DFS stage. Offtake agreements will also be finalised as the Project matures during future study phases.

## **19.9 Required Contracts for Property Development**

Various contracts should be in place before the property could be developed. Examples of possible contracts include construction, mining, concentrating, smelting, refining, transportation, handling, sales etc. Various government and landowners' agreements might also have to be in place. The Definitive Feasibility Study will unpack the detail of these contracts and will indicate possible timelines and stages of negotiation.



## 20 Environmental Studies, Permitting and Social or Community Impact

### 20.1 Known Environmental Aspects

A significant amount of information on the local environment has been collected over the past 10 years. Most of survey work was conducted between 2007 and 2012 to support a previous project EIS. Although the EIS was not finalized, the surveys produced a large amount of data and information relevant to the current project and substantially more than would usually be available at the PFS stage of similar projects. Some of this information, such as meteorology, hydrology and water quality, remains relevant to the Project (with the addition of recent data), while other information such as biodiversity and community health and demographics will require updating for use in the preparation of the EIS. Some data gaps remain and several environmental aspects will need to be addressed in the design of the Project and in the preparation of the EIS.

This section summarizes key information on the biophysical environment and socio-economic setting for the Project to establish the context in which project environmental aspects and plans are identified and discussed. This information is presented for the mine site area, the Yandera to Cape Rigny Link, and Cape Rigny and associated coastal terrain through which project infrastructure will pass.

#### 20.1.1 Biophysical Environment Setting and Aspects

Environmental studies to characterize the baseline biophysical environment for the Project and to identify potential aspects and risks have been carried out for the following environmental aspects:

- Terrestrial environment:
  - Ambient environment – air quality, noise and vibration.
  - Land – landscape, geology, geochemical characterization.
  - Water – hydrology, surface water quality and groundwater and water use.
  - Biodiversity - flora and fauna, freshwater aquatic.
  - Archaeology and cultural heritage.
- Marine environment:
  - Physical - sediments, ocean floor currents, oceanographic profiling and upwelling.
  - Biodiversity – near shore marine environment.

This section summarizes the key findings of these studies and discusses environmental aspects and risks of the Project. Potential risks involved in the environmental permitting for the Project are also discussed.



## 20.1.1.1 Biophysical Environment Setting

### 20.1.1.1.1 Geographic Setting and Geology

- Mine Site

The proposed mine site is located at approximately 1,900m elevation on the northern side of the Bismarck Range, around 13km east-northeast from Mt Wilhelm, and is bounded to the southeast by the extensive floodplain of the Ramu River (Figure 20-1) (also see Section 5.1.1). The mine site area is located on steep slopes (Figure 20-2) bounded by river gorges, in particular the Imbrum River valley to the west and the Tai-Yor River valley to the east (Figure 20-3).

The Yandera copper deposit is a northwest-southeast oriented structural feature approximately 2,000m long by 700m wide. This is discussed in further detail in Section 7.

At the local scale, the geology consists of Dioritic and Dacitic porphyries intruding the monzonite-granodiorite of the Bismarck intrusive complex. The porphyries follow the general northwest-southeast regional trend and are cross cut by southwest-northeast dislocations and later intrusives. Associated with the main porphyries are breccia zones principally identified at Omora and Gremi. The mineralization comprises mainly pyrite, chalcopyrite and bornite in the hypogene zone and in the oxide and mixed zones minor malachite, chrysocolla, and some chalcocite are the main copper minerals. Occasional native copper is noted at Omora. Molybdenum mineralization is dominantly molybdenite as fracture coatings. Gold and silver are present throughout the system in relatively minor quantities. Significant precious metal concentrations formed late in this area and appear to be localized within structural zones.



**Figure 20-1: Ramu River at the Foot of the Bismarck Range**



**Figure 20-2: Typically Steep Landscape around Mine Area**



**Figure 20-3: Tai-Yor River Valley with Yandera Exploration Camp and Village in Foreground**

- **Yandera to Cape Rigny Link**

The Yandera to Cape Rigny Link will be approximately 146km long and traverse a diverse range of geography. From the mine site to the Ramu River bridge, the access route and pipeline would pass through rugged terrain, with steep slopes and unstable hillsides. The geology of this area includes alluvial fan deposits of clay, sand, boulder and gravel on the flats around the Ramu River, rising through the Marum Basic Belt, composed of dunite, serpentinite, minor pyroxenite and the Asai shale, composed of schistose phyllitic and carbonaceous shale, siltstone and mudstone.





From the Ramu River bridge to near the coast, the link will roughly follow the existing Ramu mine infrastructure and road network. The Yandera to Cape Rigny Link would then diverge eastward along the Rai Coast to the coastal facilities at Cape Rigny. The current road route south from Madang to the Ramu Valley traverses coastal flats before crossing the Finisterre Range. The course of the Ramu River meanders extensively within the valley.

The river alluvium comprises clay, silt, sand and gravel, with cobble and boulder sized material observed in the river channel. The river is located towards the southwestern edge of the wide valley due to a greater rate of tectonic uplift occurring northeast of the valley compared to the southwest. The alluvial fans, which occur on the edges of the valley, comprise similar material to the river alluvium, although with a higher proportion of larger sized particles.

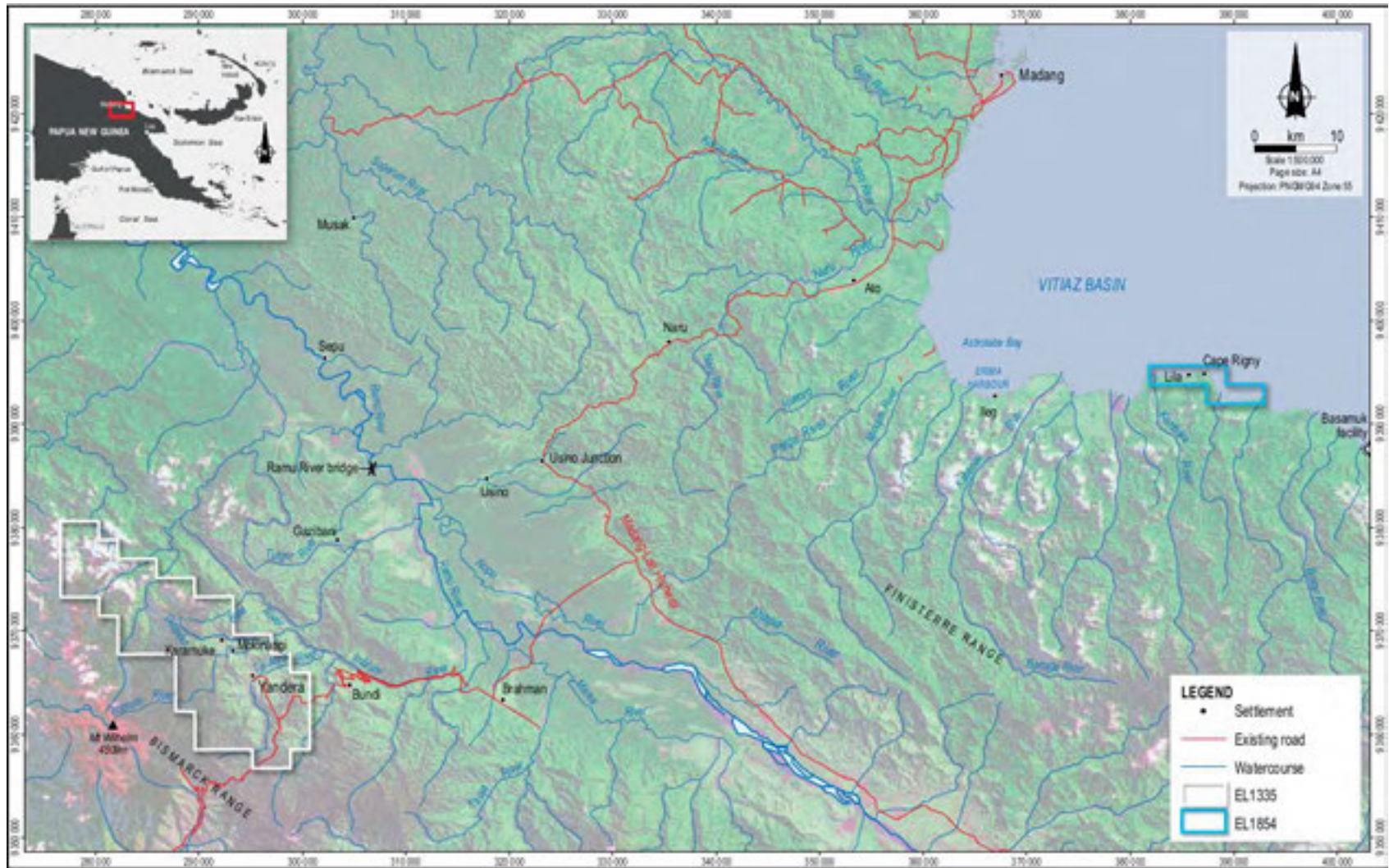


Figure 20-4: Yandera Copper Project Location



- Coastal Area

Coastal infrastructure will be located at Cape Rigny in an area of gently undulating plains intersected with braided rivers and smaller watercourses that discharge to the sea (see Section 5.1.1). Onshore, relatively variable alluvial materials comprising clay, silt, sand and gravel underlie the terrain of the Rai Coast.

#### 20.1.1.1.2 Drainage and Water Quality

- Mine Site

A number of creeks and rivers drain the mine site and waste rock dump area. Most creeks draining the area flow into the Tai-Yor River, which flows north then east down the northern side of the Bismarck Range to join the Imbrum River. The proposed access road would traverse the Tai-Yor, Imbrum and Ramu River catchments. Both the Imbrum and the Baia rivers join the Ramu River upstream of watercourses that drain the Ramu Nickel mine site (see Figure 20-1).

Water quality data is available for the Tai-Yor, Imbrum and Baia river catchments from previous environmental studies. The data indicates that water quality is generally adequate for the maintenance of aquatic life and is suitable for drinking (through comparison of water quality data with Schedule 1 of the PNG Environment (Water Quality) Regulation 2002 and Schedule 2 of the PNG Public Health (Drinking Water) Regulation 1984). During the drier months of May to September, these rivers and streams tend to have relatively low turbidity. In the wetter months, turbidity is elevated (often being over 500 NTU; Coffey, 2012a) with runoff from land cleared for exploration drilling and low-level subsistence agriculture and landslips accounting for a large component of the sediment reporting to the rivers in this area. Surface runoff from the proposed mine area would generally report to the Tai-Yor River.

Data obtained from water quality monitoring at three sites (Tai-Yor River at Yandera, Dengru Creek downstream of the pit areas and Mogoro Creek upstream of Yawagu Creek) in watercourses in the headwaters of the Tai-Yor River (see Figure 20-1) show elevated concentrations of dissolved copper, manganese, molybdenum and zinc compared to other sites sampled in September 2016 and May 2017. These results indicate some influence on water quality of the mineralized geology in this catchment. Concentrations of all metals were below PNG water quality standards for drinking water and aquatic ecosystem protection.

- Yandera to Cape Rigny Link

The main watercourse traversed by the Yandera to Cape Rigny Link is the Ramu River some 20km east of the mine site. From its headwaters near Kainantu in the south, and in the Finisterre Range to the north, the Ramu River flows northwest along the Ramu-Markham graben to its mouth at Venus Point on the Bismarck Sea. The river has a catchment area of 18,500km<sup>2</sup> over a linear distance of some 350km. At its mouth, the Ramu River has a mean freshwater discharge of approximately 1,000m<sup>3</sup>/s (Löffler, 1977).

The Ramu River is actively migrating laterally throughout its length and is characterized by high sediment loading from the tectonically active Finisterre Range. The Ramu River flows in a braided channel and is characteristic of a high-energy flow combined with a high sediment load and high turbidity. Downstream of Brahman, the river meanders across the floodplain with high rates of lateral channel migration.



- Coastal Area

A number of watercourses drain into the sea along the Rai Coast, from shallow, fast-flowing, braided channel streams to deeper, slower flowing single channel streams (GHD, 2012). Gravels and cobbles typically dominate these streambeds. A prominent alluvial fan associated with an unnamed river is located some 8km west of Cape Rigny. Further characterization of the watercourses along the coast and at Cape Rigny would be completed prior to submission of the EIS.

### 20.1.1.1.3 Terrestrial Biodiversity

The vegetation of the project areas is described in Section 5.1.2.

Surveys and assessment carried out in 2012 (3D Environmental, 2031) identified 23 species of conservation significant fauna species (under IUCN criteria) as potentially present in areas proposed for project development. Three 'Critically Endangered' and two 'Endangered' mammals were identified (including the eastern long-beaked echidna (*Zaglossus bartoni* diamond), and the black-spotted cuscus (*Spilocuscus rufoniger*)) along with seven 'Vulnerable' bird species, one 'Endangered' reptile species and one 'Near Threatened' butterfly species. 3D Environmental noted that many threatened species, particularly large mammals, are likely to have been extirpated from areas potentially impacted by the Project in favour of undisturbed habitats peripheral to the project footprint.

Lowland forests and river systems near the project area are known habitats for many of these species. High value habitat is associated with Northern Papua New Guinea Lowlands Ecoregion traversed by the Yandera to Cape Rigny Link. These essentially undisturbed lowland forests include extensive undisturbed tracts of mixed hill forest on the Ramu Valley foot slopes and Northern Coastal Ranges, and mixed alluvium/mixed swamp forests of the Ramu floodplain. The project area is also located within two Endemic Bird Areas (EBAs), the Central Papuan Mountains EBA (mine area) and the Northern Papuan Lowlands EBA. The EBAs are considered the most important places for habitat-based conservation of restricted-range birds. High value fauna habitat is also located on the Ramu Highway to the south of Madang (about 10km north of Ato) associated with the Balek Wildlife Sanctuary.

### 20.1.1.1.4 Freshwater Aquatic Biodiversity

A freshwater aquatic biodiversity study was conducted as part of the previous EIS (GHD, 2012). The areas investigated included the upper catchments (at the mine site), the Ramu basin floodplain (Ramu River and downstream of the Ramu River/Imbrum River confluence) and Rai Coast catchment streams.

The data from that study suggested that aquatic habitats are in generally good condition, although are exposed to pressures from mining, forestry, artisanal gardening, fishing and hunting and natural disturbances such as landslips.

Results from the analysis of fish tissue for metals from this study showed no elevated concentrations in flesh, even though the fish were exposed to elevated dissolved copper and zinc in the Ramu River and streams draining the mine area (upper Tai-Ayor catchment).





The waterways studied host a diverse and abundant macro invertebrate fauna. Diversity in upland stream riffle habitat is particularly high, where water quality is also relatively high. A number that are highly pollution-sensitive were recorded among the macro invertebrate taxa recorded. The most pollution-sensitive taxa recorded occurred largely in the upland stream habitat near the mine site. Floodplain river reaches and off river water bodies tended to host predominantly pollution-tolerant and moderately pollution-sensitive taxa, generally reflective of lowered water quality and habitat diversity.

#### 20.1.1.1.5 Nearshore Marine Environment

The near shore marine environment along the Rai Coast at Cape Rigny comprises nearshore fringing coral reefs characterized by a shallow reef flat extending approximately 10m from the shore, a reef crest and an outer slope. The presence of these healthy reefs is reflective of good water quality and a lack of riverine sedimentation in this coastal area. Beyond the crest, the bathymetry is very steep, and as depth rapidly increases to 20m and beyond, hard corals become less abundant. The fringing coral reef is structurally more diverse at exposed headland locations than in the more sheltered embayments, or near river mouths along the coast. Figure 20-5 shows the near shore marine environment at Cape Rigny.

The fringing reefs provide habitat for common small and nearshore pelagics species (ocean fish) such as flying fish (Exocoetidae), needlefish (Belonidae), sharks (primarily *Charcarinidae*), trevally (*Carangidae*), skipjack tuna (*Scombridae*), Spanish mackerel (*Scombridae*) and yellowfin tuna (*Scombridae*).

Subsistence fishing occurs for reef fish, molluscs and crustaceans (and occasionally for pelagic fish) along the Rai Coast.

Further studies will be conducted to characterize nearshore marine environment prior to submission of the EIS, including studies of water quality, sediment deposition, benthic habitats and marine fauna.



**Figure 20-5: Nearshore Marine Environment at Cape Rigny**



### 20.1.1.1.6 Deep-ocean Marine Environment

The offshore area in the Rai Coast region is dominated by a series of dendritic submarine canyons that extend from the shoreline, and progressively merge as depth increases to the northeast, ultimately flattening out to form the floor of the Vitiiaz Basin. The canyons are characterized by continuously sloping canyon floors with steep-sided walls. Many rivers with high sediment loads drain into the basin from the Rai Coast, depositing sediment along the floor of the submarine canyons.

The bathymetry offshore from Cape Rigny rapidly increases in depth only a short distance (less than 1km) from the shoreline (Coffey, 2010). This rapid increase in depth and relatively steep seafloor slope continues until approximately 600m depth. From 600m to a depth of 1,000m, the overall seafloor slope is less steep. Submarine canyons are also present, some of which continue to the limits of the survey area at about 1,000m.

The ocean currents of the northern coast of PNG (including off the coast of Cape Rigny) are dominated by the variable New Guinea Coastal Current (NGCC) at the surface, and the more stable New Guinea Coastal Undercurrent (NGCU) in the deeper subsurface layers of the ocean. These currents form part of the Low Latitude Western Boundary system of the South Pacific, which connects subtropical and equatorial water masses.

During the southeast monsoon season (May to October), the South Equatorial Current (SEC) is the major surface current system of the southwest part of the Pacific Ocean. The SEC is composed of a broad westward flow of water on the northern arm of the South Pacific gyre. The SEC is a wind-driven, surface-current system and generally flows between the equator and latitude 20°S.

Deep-sea sediment sampling off the coast of Cape Rigny (up to 40km offshore and at depths between 825 to 1,511m) was carried out in 2012. Sediments from most sites sampled consisted of a fine silt surface overlying a silt/clay subsurface, scattered organic material and traces of sand (Coffey, 2012b). Total carbon content was very low at all sites (3% or less), with the portion of organic carbon and inorganic carbon being very similar at all the sites. At most sites, nickel exceeded ANZECC/ARMCANZ (2000) sediment quality guidelines (Simpson, et al. 2013), indicating natural enrichment of this metal in sediments.

Diversity of macrofauna taxa in the sediments was very high with 60 different taxa identified.

Previous investigations into deep-sea sediment rates offshore from Cape Rigny found that between June and September 2010 sedimentation rates were highly variable ranging between 0.001 to 35.98mm/a. The average sedimentation rate during that time was 6.3mm/a. The measurements were made at a depth of about 1,050m and at 117m above the seafloor. Given the height above the seafloor, this natural sediment deposition is likely due to riverine inputs rather than resuspension of the bed sediments.

### 20.1.1.2 Biophysical Environment Aspects

This section describes the key aspects related to the biophysical environment – specifically, those aspects which have the potential to materially impact on aspects of the environment, and the approvability and cost of the Project.





### 20.1.1.2.1 Terrestrial Mine Material Management

The project will store in the order of 700Mt of waste rock in a valley-fill waste rock dump. In a PNG mining context, this is a very large amount of waste rock. In addition to waste rock, the waste rock dump will also include stockpiled, low-grade ore that will be mined late in the mine life.

Adverse impacts to the receiving environment may occur if there is inadequate characterisation, storage and management of ore, waste rock and tailing during operations and closure.

Aspects related to the management of these mine materials include:

- Discharges of acid and metalliferous drainage (AMD) and neutral metalliferous drainage (NMD) from potentially acid forming (PAF) ore and waste rock during operations and post-closure, affecting downstream watercourses, habitats and water resource users.
- Discharges of poor quality runoff and seepage from non-acid forming (NAF) waste rock and ore stockpiles, and the open pits degrading surface and groundwater quality and affecting downstream watercourses, habitats and water resource users.
- Stability of the waste rock dump.
- Unsuitability of waste rock material for use in rehabilitation and closure.

Ore and waste rock have the potential to generate acid due to the oxidation of contained sulphide minerals, resulting in the formation of acid and subsequent mobilization of heavy metals into surface runoff and groundwater. Previous geochemical testing (EGi, 2011) showed that approximately 20% of the waste rock (from the Imbruminda, Gremi and Omora deposits) is PAF. The geochemical test work identified the following preliminary criteria for waste rock classification:

- NAF: Total sulphur less than or equal to 0.2% sulphur.
- PAF-LC (potentially acid forming – low capacity): Total sulphur 0.2% to less than 0.6% sulphur.
- PAF: Total sulphur greater than or equal to 0.6% sulphur.

The 2011 test work identified that the Gremi, Imbruminda and Omora PAF-LC waste rock is slowly reactive with a lag period (i.e., period before the onset of acid conditions) likely to be more than two years. Kinetic test work on waste rock samples from these deposits also indicated that neutral drainage might occur over time.

The work found that the lag period of the Omora PAF material is in the order of 12months but areas with low pH are likely to develop earlier than 12months, with seepage likely to have a pH of less than four and contain elevated concentrations of aluminium, cobalt, copper, manganese and zinc. A programme of segregation and selective placement of PAF and PAF-LC material types will be required to effectively manage AMD and to mitigate potentially significant AMD issues.



Management measures will need to include limiting the exposure of PAF material to air and water. Segregation and encapsulation of PAF material will be required to minimise the risk of AMD. Erosion control measures will also be needed to prevent exposure due to weathering of PAF material in waste rock dumps, and tailing and ore stockpiles. EGi (2011) noted that PAF-LC material would be amenable to neutralization by higher acid neutralizing capacity rock types or treated with crushed limestone. Stockpiled PAF material will need to be stored under a NAF cover to avoid the formation of AMD.

A geochemical assessment of the Dimbi and Dimbi West (Gamagu) is currently underway. This work will investigate the acid forming potential of material from these deposits and develop recommended measures for the management of the material. A comprehensive geochemical assessment will also be conducted as part of the EIS, which will include further acid-base accounting of ore, waste rock and tailing. The work will also include geochemical modelling to assess downstream water quality and will outline measures for minimizing environmental impacts due to AMD. The use of deep-sea tailing placement (DSTP) for tailing management will avoid the risk of AMD from an on-land tailing storage facility, as the tailing will be stored permanently under seawater.

Waste rock will also be end-tipped from the south of the Omora Pit downslope into the waste rock dump (i.e. a controlled failing dump). Such an approach could have significant implications for the integrity of the waste rock dump and the control of AMD. The behaviour of the failing dump and the likely movement of waste rock down Mogoro Creek within the waste rock dump will need to be investigated, in particular implications for the structural integrity of the dump and the potential to generate AMD. The end-tipped waste rock will not be treated, and could generate AMD within the waste rock dump. These risks and potential impacts will need to be thoroughly assessed and measures implemented to safeguard the structural integrity of the waste rock dump and effectively control AMD. The use of controlled failing of waste rock dumps can be controversial in PNG and could present a permitting risk to the Project if these aspects are not adequately addressed.

The management of soft (incompetent) waste rock will also be a crucial aspect for the Project as such material may not store safely in the waste rock dump nor be suitable for use in rehabilitation and closure.

#### **20.1.1.2.2 Water and Soil Management**

The mine area is located in steep terrain on the northern slopes of the Bismarck Ranges in a high rainfall environment and at the headwaters of the Tai-Yor River. Land disturbance caused by vegetation clearance and earthworks required to construct and operate the mine and access roads will expose the earth to erosion through rainfall runoff. The key sources of sediment runoff will be the waste rock dump, pit voids, ore stockpiles and access roads (including through sidecasting).

A key environmental aspect is the potential for increased sedimentation of surface watercourses if upstream sediment control measures are inadequate. The project will need to ensure erosion and sedimentation control measures are appropriately designed and adequately maintained during construction and operations to avoid impacts associated with increased sedimentation of watercourses. Such impacts could include decreases in water quality and subsequent effects on downstream water uses (e.g. drinking water use) as well as riparian and aquatic habitats and biota.



In particular, the natural flow regime (i.e., bed aggradation) and water quality (i.e., increased turbidity and increased metals concentrations) in Tai-Yor River could be affected given that it is the river draining the mining and waste rock storage areas. This river is a key resource for Yandera village, supplying the over 4,000 residents with their primary source of water for drinking, washing and other activities and cultural values. A reduction of water quality of the Tai-Yor River could reduce the usability of the river by villagers and significantly affect the quality of their life.

Sidcasting during access road construction will result in sedimentation of adjacent drainage. The use of sidcasting is likely to be scrutinized by reviewers of the EIS and regulators. Sidcasting has been a concerning issue for PNG regulators at other projects including Hidden Valley. The project will aim to minimise its use wherever feasible.

Soil erosion and sedimentation impacts will be managed by limiting ground disturbance through careful planning of site components including identifying high-risk areas, minimising disturbance footprints, using competent rock material for construction of a stable waste rock dump, and installing adequate drainage diversions and erosion controls.

Sedimentation ponds will be installed downstream of the waste rock dump and mining precinct (at the Tai-Yor River), and downstream of the Gremi pit (at Denguru Creek). Sediment collected in these ponds will need to be disposed of appropriately to avoid sediment-laden runoff entering the Tai-Yor catchment. Suitable means of disposal of this material needs to be investigated. The water quality of the ponds will also need to be managed to minimise impacts to downstream environments.

All point source discharges will need to comply with environment permit criteria and be monitored on an ongoing basis against the criteria.

Some sections of the upper Tai-Yor River will be diverted around the mine precinct. The mining precinct is directly downstream of the waste rock dump and pits. Subsequent changes to the hydrology in this catchment will need to be investigated, particularly the risk of flooding.

### **20.1.1.2.3 Deep-sea Tailing Placement**

Deep-sea tailing placement is the preferred option for managing tailing for the Project, noting that the EIS must also include a credible assessment of an on-land tailings storage option.

This DSTP method would involve tailing disposal via a mix tank/pipeline system to a subsea slope, with the tailing settling at depths of around 1,000m below sea level. Environmental aspects associated with DSTP include:

- Potential biophysical affects to the marine environment, in particular from long-term settlement of tailing material on the ocean floor smothering marine organisms.
- Potential upwelling of tailing plumes from the outfall into the primary production zone in the upper water column, increasing turbidity with subsequent effects on marine species (including those used by people) that inhabit these shallower marine area. These impacts could also occur because of a potential rupture of the tailing pipeline caused by abrasion of the pipe or floating of the pipe due to entrained air bubbles, as well as storms.



Given current data and the flotation method proposed to extract the copper concentrate, the toxicity of the DSTP discharge is expected to be relatively low in comparison to some other DSTP projects in PNG. Further geochemical testing to confirm the characteristics of the tailing discharge will be carried out as part of the preparation of the EIS.

Modelling of the behaviour and fate of the DSTP discharge will be modelled as part of the EIS. This will include determining where the tailings density current will migrate and where tailings will deposit on the seafloor. Importantly the modelling will also demonstrate where tailings sub-surface plumes form in relation to primary production zones in the water column such as the surface mixed layer and euphotic zone.

#### **20.1.1.2.4 Nearshore Marine Impacts**

The construction of the wharf facility at Cape Rigny will require dredging and the placement of materials in the nearshore marine environment. Environmental aspects associated with the construction and operation of the wharf include:

- Disturbance to seabed sediments and associated habitat and species within and adjacent to the footprint of the wharf with mobilization of sediments in the water column and temporary increases in turbidity in coastal waters. The increased sediment may smother the fringing coral reefs in the Cape Rigny area. Impacts to subsistence fishing practices may also occur.
- Accidental spillage of concentrate (or other potentially hazardous materials) during loading to ships, as well as uncontrolled discharge from the DSTP system (e.g., from pipeline rupture) to the shallow water environment, degrading water quality with subsequent effects to marine flora and fauna species.

Implementation of sediment control measures will be needed to minimise impacts in the nearshore marine environment. Studies of nearshore sedimentation and fringing reef condition, and a nearshore marine impact assessment (including assessment of accidental events) are proposed as part of the EIS studies and assessment programme.

#### **20.1.1.2.5 Rehabilitation of the Mine Site**

The scale and nature of rehabilitation of the mine site, waste dumps and project infrastructure will be a key environmental aspect for the Project. The long-term integrity, end use, closure and rehabilitation of disturbed areas will need to be assessed. The pit voids and the waste rock dump will need to be monitored and managed, as required, in perpetuity.

A conceptual plan for the successful and safe rehabilitation and closure of the mine, with closure objectives will be developed in consultation with stakeholders. Section 20.1.1.7 for the proposed scope of work (to be conducted during the EIS) for developing the conceptual mine closure and rehabilitation plan.

Proposed final land use options for the major project components include:

- Mine pit voids – to remain as a permanent feature of the landscape and allowed to flood.
- Flotation plant, mill site and mining precinct – to be demolished and the disturbance area rehabilitated to resemble native vegetation as close as practicable.



- Infrastructure corridor - concentrate and tailing pipeline to be removed and the disturbance area rehabilitated to resemble native vegetation as close as practicable. The access roads will remain upon decommissioning.

Environmental aspects associated with project closure include:

- Availability of sufficient rehabilitation material, such as topsoil and non-acid forming (NAF) material.
- Availability of recolonization plant species.
- Unrealistic expectations for post closure activities and associated demands from local communities.
- The long-term stability and structural integrity of the waste rock dump.

Section 20.5.3 provides a preliminary estimation of closure costs.

#### **20.1.1.2.6 Dust, Noise, Vibration and Gaseous Emissions**

The project will generate noise and vibration during construction and operations, primarily at the mine site. Key sources of noise and vibration will be from drills, shovels, blasting, dumping/hauling of ore and overburden, and the operation of the concentrator plant at Cape Rigny. The project has the potential to generate dust wherever the ground surface is disturbed (principally in the mine area and along haul roads); gaseous emissions from the concentrator plant, and exhaust gases from haul trucks and other equipment.

The project areas are located remotely from major industrial or anthropogenic emission sources likely to contribute to atmospheric pollution or elevate ambient noise levels. As a result the Project will need to manage the effects of noise, vibration and air emissions on the general safety and amenity of residents and other sensitive receptors in the project area through implementation of standard management measures such as dust suppression, installing noise suppression devices where required, and consultation with local communities.

Impact assessments will be conducted as part of the EIS preparation for noise, vibration, and air quality and greenhouse gases.

#### **20.1.1.2.7 Biodiversity Impacts**

Project activities could affect sensitive ecological values such as conservation areas, valuable habitat and/or threatened species. Studies and assessments carried out for the previous EIS (3D Environmental, 2012) identified the following key biodiversity aspects:

- Loss of habitat for flora and fauna species through direct clearing of vegetation.
- Direct mortality of flora and fauna species during construction and habitat clearing.
- Edge effects associated with vegetation clearing, including weed invasion, increased predation and competition, and changes in abiotic conditions.
- Dissection and fragmentation of habitat and populations of fauna and flora species through development of infrastructure, including mining pits and access roads.
- The loss or modification of habitat important for threatened flora and fauna species including the creation of dispersal and movement barriers.



- Toxic substances introduced into the habitat as well as other sources of pollution including noise and artificial light.
- Changes to other ecological processes such as the fire regime.
- Increased pressure on resources through changes to population induced by the development, such as hunting and increased demand for wood.

A range of management measures will be needed to address biodiversity aspects including locating infrastructure within existing easements, disturbed areas, and reducing the level of vegetation clearance and disturbance, particularly in areas of intact primary forest in the Ramu River valley.

## **20.1.2 Socio-economic Setting and Aspects**

### **20.1.2.1 Socio-economic Setting**

#### **20.1.2.1.1 Mine Site**

Six villages or hamlets occur within or adjacent to the mine site area. The closest is Yandera village, located immediately east and downslope of the mine site (Figure 20-6), and outside the current SML. The villages of Mokinangi, Mangaia, Ongoma, Kindaukevi, Imuri, Karizokera and Rurutara villages are located around the mine site (within about 5km of the mine site). A number of clan boundaries cross the mine site area, though all villages are part of the one local landowner group.

'Gende' is the name of the local language and cultural group in this area.

The Gende communities practice shifting cultivation, clearing forest to create new food gardens, hunt wildlife, and collect bushland resources from the surrounding forest. This pattern of deforestation is typical of PNG and is clearly visible in figures 20-6 and 20-7. A complex system of walking tracks has been developed throughout the project area that are well maintained and used for hunting and collection of forest resources. No road connections are available for many Gende communities to the coast or the Highlands Highway.

Zimmer-Tamakoshi (2008) noted that the Gende were typical of PNG highlanders, whereby their traditional patterns of leadership and social behaviour were grounded in patrilineal principles of descent and land use. The land was pivotal to the Gende identity as it defined status, wealth, kinship, and culture. The land provides a link to the past in the form of sacred sites and stories, and sustains present and future generations by providing space and materials for shelter, fertile soils for planting subsistence gardens, and plentiful bushmeat for hunting.

The Gende traditionally lived in small, fenced villages or hamlets, which reflected significant separation of gender roles (Zimmer-Tamakoshi, 2010). Women lived on the edges to allow access to the gardens, and the men lived in the centre of the hamlet. Communal houses were divided into men and women's sections with separate entrances for each gender. The size of these hamlets varied significantly over time and usually stemmed from a core group of males (descended from men who settled and first cleared land in the general locality of the hamlet), their wives, sons and unmarried daughters.





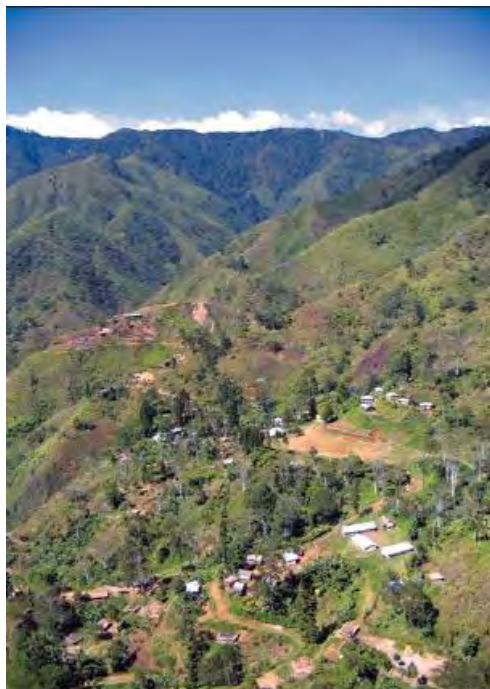
Yandera is the most populous village near the mine area, with an estimated population of more than 4,000 people. Yandera is also one of the most developed in the region due to its history of interaction with various mining companies throughout exploration phases. Yandera village is divided into two major clans, the Yandima and Tundiga clans.

As such, housing in Yandera is split into two sections to reflect these clan boundaries. The other smaller villages are generally divided into two sub-clan groups under the primary Gende clan - the Gegeru and Karizoko clans - with whom the local residents near the mine area identify themselves. A significant number of local people from Yandera and other nearby villages or hamlets have been or are employed in some manner through activities associated with the Project. Numbers have fluctuated depending on the level of exploration activity.

The nearest health centres are located at Usino and Walium, approximately 35km and 38km (two days by foot and vehicle) respectively from the mine site. Historically, Yandera has been serviced by a well-equipped and staffed clinic operated by the Yandera mining project. The clinic essentially provided medical services to anyone in need from nearby villages and in some cases the Project would facilitate the transportation of seriously ill or injured persons from nearby villages to the clinic and/or to medical facilities in Madang.

A study in 2007 identified that many children were able to attend most of their schooling in Yandera itself; the primary school taught classes up to Grade 8 (Zimmer-Tamakoshi, 2008). Beyond that, students needed to travel to Brahman (with classes up to Grade 10) or other high schools throughout the country.

Approximately 540 students attended one of seven elementary and primary classes at Yandera when surveyed in 2011. This was likely to represent most if not all the school-aged population of Yandera, that is, the significant majority who could attend school at Yandera did. The school was said to operate with an adequate number of trained teachers, albeit not consistently. Teacher attendance was reported to be inconsistent and teachers, who generally came from elsewhere, grew intolerant of the isolation of Yandera and failed to stay for the longer-term.



**Figure 20-6: Yandera Village**



**Figure 20-7: Vegetation around the Mine Area**

#### **20.1.2.1.2 Yandera to Cape Rigny Link**

The variety of geography through the link is reflected in the diverse ethnic cultures in the region, with the Yandera to Cape Rigny Link traversing several clan and language boundaries, as well as a number of districts.

Villages along the Ramu Highway such as Usino and Naru have experienced in-migration and establishment of squatter settlements, largely because of employment opportunities at the Ramu and Yandera mines.

The villages between the Bismarck Range and the foothills of the Finisterre Range are strategically placed for trade networks, having access to lowland resources that are highly valued by upland peoples (Conton, 1996).

#### **20.1.2.1.3 Cape Rigny**

The two villages at Cape Rigny, Lila and Kul, are home to the Siroi people. The local economy is based on farming (fruits and vegetables), cash crops, pig raising and freshwater and ocean fishing. Along the Rai Coast, cocoa and copra are the major cash crops (Zimmer-Tamakoshi, 2010). The raising of pigs is less prominent at Cape Rigny than the highland regions (less than 40% of households at Kul and nearby villages). The Ramu Nickel Project at the Basamuk processing site (Zimmer-Tamakoshi, 2010) has employed a few people from this area. This facility is located 30km to the east of Cape Rigny.

Cape Rigny is traversed to the south by a road and slurry pipeline associated with the Ramu Nickel Project, which passes immediately adjacent to the processing plant site. The presence of this infrastructure is likely to have influenced the socio-economic characteristics of the area through provision of road access and employment opportunities that the Basamuk facility offers.



### 20.1.2.2 Socio-economic Aspects

Addressing social aspects and the consent of customary landowners are prerequisites for the successful development and operation of projects in PNG. The statutory requirements of the Environment Act 2000 also need to be met. A socio-economic impact assessment is therefore included as part of the EIS programme (see Section 20.1.125).

The PNG Conservation and Environment Protection Authority (CEPA) requires proponents to differentiate socio-economic impacts into two distinct groups (Group A and Group B) to make clear which impacts will occur as either a direct or indirect result of the Project (DEC, 2004). As described in DEC (2004):

- Group (A) impacts are those that can be identified and addressed by the CEPA environmental impact statement (EIS) approval process. They arise directly from adverse impacts upon the biophysical environment as caused by the development.
- Group (B) impacts are secondary socio-economic effects that are reasonably expected to manifest themselves and are normally best handled by the responsible National, Provincial or Local Level Government agencies.

Key socio-economic aspects which are likely to arise from the Project include those related to the alienation of land from customary use due to the exclusive need of land for mining, ore processing and project infrastructure; in-migration and associated impacts (e.g., law and order, communicable disease, social tension); and potential human health impacts to downriver communities and those near Cape Rigny. These potential aspects are summarized below, according to whether they may lead to Group A (direct) or Group B (indirect) impacts.

- **Group A Impacts (Direct)**

Direct benefits/positive impacts include:

- Increased employment and training opportunities (human development) for landowners and other affected communities.
- Generation of human (as well as financial) capital, underpinning further economic and social development in PNG.
- Increased incomes from employment and other benefit streams.
- Generation of business opportunities to directly service the Project.
- Impacts on social and physical infrastructure and the capacity for existing infrastructure to support development associated with new business opportunities.
- Continuity within the PNG mining sector and with it the maintenance of expertise, on which PNG's future mining industry depends.
- Maintenance of infrastructure and revenue streams following mine closure (early or planned).
- Increased Government tax and royalty revenue.

Direct aspects/potential adverse impacts include:

- Loss of land due to the establishment of project components and consequent impacts on subsistence living due to loss of resources such as gardens and hunting and gathering areas.



- Resettlement of villages within mine tenements. Some resettlement of villages will be required to develop the Project, including those within the project footprint of the mining area and coastal facilities area. The PNG Government would likely expect that residents of the villages within the SML be resettled. Resettlement of small villages is common for mining projects in PNG. Yandera village is outside the SML, although its residents are likely to experience significant impacts on the resources they rely on, principally clean water. Resettlement of Yandera village would be very challenging and expensive given its population (some 4,000 people). An approach is needed to either managing the resettlement of Yandera village or effectively controlling the impacts of the Project on resources key to the ongoing viability of the village.
- Changes to the hydrological regime within the catchment of the mine area and the rivers downstream of the Project and consequent impacts on relevant beneficial values associated with the river, such as fishing and use of riverine resources.
- Reduced amenity from reduction in air quality, increased noise and visual impact and associated consequences on quality of life for affected people.
- Loss of, or damage to, archaeological or cultural sites and practices.
- In-migration and its associated potential impacts on social cohesion, safety and security, health, land use, services, infrastructure and accommodation. The greatest in-migration is expected to be in the areas of larger villages in the mine area such as Yandera.
- Potential human health impacts to downriver communities and those near Cape Rigny due to mine waste discharges.
- Over-reliance on finite mine-related benefits such as direct and indirect employment resulting in future inability to subsist using traditional practices.
- **Group B Impacts (Indirect)**  
Indirect benefits/positive impacts include:
  - Improved national balance of trade, infrastructure development and commercial, employment and educational opportunities.
  - Indirect stimulation of PNG's economic sectors that drive local, provincial and national economic growth.
  - Increased migration and associated potential impacts on social cohesion, safety and security, health, land use, services, infrastructure and accommodation. This may also result in increased demand for local food products and timber, as well as increased local incomes through the expansion of cultivation of gardens for produce, fishing activity and small-scale logging, with consequent changes in the consumption patterns of local villagers and associated impacts such as increased generation of domestic wastes.Indirect potential aspects/adverse impacts include:
  - Pressure on Local, Provincial and National Government capacity to plan for and implement social development.
  - Law and order aspects resulting from migration, changed mobility and destabilized social structure.
  - Increased rate of the contraction and spread of HIV/AIDS.



### 20.1.3 Risks to Permitting

The major risks to permitting for the Project, and in particular in obtaining an environment permit include:

- Inadequate baseline data collection and/or impact assessment, resulting in amendments and supplementary studies (and subsequent delays) before the Project can be approved.
- Delays in submitting the EIS due to changes to project engineering design and subsequent revisions to EIS study scopes, extending the approval timelines.
- Potential for landowner disputes resulting from unrealistic community expectations and restricted land access, leading to lengthy negotiations and disruptions during the EIS and approvals process.
- Local community disaffection with the Project. Campaigns against the Project could result in increased costs and delays.
- Negative perceptions of DSTP by opponents. Strong opposition to DSTP at Cape Rigny can be expected from some stakeholders (e.g., coastal communities and NGOs).
- Impracticable or unachievable environment permit conditions imposed by regulators leading to increased costs and programme delays.
- Changes to environmental legislation, with effects on environmental and social study requirements with cost increases and schedule delays.
- The practice of end-tipping waste rock from the Omora pit into the Mogoro valley (i.e., a failing dump) may be scrutinised by opponents of the Project and may raise concerns within the PNG Government. The practice of failing dumps can be controversial in PNG, and the Project will need to demonstrate clearly that risks from this approach can be effectively managed.

Strategies to reduce these risks to project permitting include:

- Appointing an experienced lead environmental consultant to manage the project approvals process.
- Conducting frequent government and agency consultation.
- Implementing a stakeholder engagement plan.
- Close liaison between the lead environmental consultant and project engineers so the EIS includes accurate information about the Project.
- Comprehensive and scientifically defensible environmental and social studies are undertaken, including incorporating a peer review process throughout the EIS to scrutinise the technical adequacy of the studies.

## 20.2 Requirements and Plans

### 20.2.1 Waste and Tailings Disposal

Waste rock and tailings from mining activities will need to be managed and disposed of through the life of the mine and into the closure period.



Waste rock produced during mining is proposed to be disposed of to valley-fill structures located to the southwest and southeast of the mine pit. The sulphur and metal content of some of this rock means that acid and metalliferous drainage (AMD) may be an environmental aspect at the waste rock dumpsite, as surface runoff becomes acidic and/or contains elevated levels of dissolved metals. The high rainfall (and potential for seismic activity) in the area places further importance on the need to effectively control surface water which will be the focus of further detailed engineering work.

Management measures will need to include limiting the exposure of potential acid forming (PAF) material to air and water during operations and post closure. Segregation and encapsulation of PAF material will be required to minimise the risk of AMD. Erosion control measures including sediment basins will also need to be implemented so that waste rock dumps do not expose PAF material due to weathering.

Other aspects that will be considered in the detailed design include non-acid forming (NAF) to PAF waste ratio and location(s) of NAF temporary storage facilities, the staging of mine waste rock dump ensuring continuous encapsulation of PAF material, seepage water quality and stability monitoring and closure conditions.

A geochemical assessment of the potential acid forming of the waste rock from the Dimbi and Gamagu pits is currently underway with no available results at the time of writing. This work is investigating the acid forming potential of material from these deposits and will develop recommended measures for management. Further geochemistry investigations will be conducted as part of the EIS, including acid base accounting on selected ore, waste rock and tailing samples as well as geochemical modelling of downstream water quality.

The preferred option for tailings disposal is through deep-sea tailing placement (DSTP). This option avoids the risk of AMD from on-land tailing storage, as the tailing will be stored permanently under water. The concentrator would be located at Cape Rigny, supplied by an ore slurry pipeline from the mine site.

Tailings exiting the concentrator will be diluted with seawater in a mix/de-aeration tank before entering the outfall pipeline. The depth of the outfall pipeline terminus will be at approximately 200m water depth into a subsea canyon. Cape Rigny was selected due to its sea floor gradient offshore and the presence of such canyons.

## 20.2.2 Site Monitoring

An environmental monitoring programme will be implemented to monitor and measure, on a regular basis, the environmental performance of project activities.

Monitoring will cover each of the environmental aspects and affects identified and assessed in the EIS, including:

- Air quality and greenhouse gas.
- Noise and vibration.
- Native vegetation clearance and rehabilitation.
- Prevalence and control of weeds, pests and pathogens (terrestrial and aquatic).
- Aquatic and terrestrial flora and fauna.
- Seepage from waste rock dumps (for early identification of AMD).





- Groundwater.
- Discharges into watercourses.
- Surface water and sediment quality in affected and control catchments.
- Discharges into the marine environment, particularly associated with DSTP.
- Solid waste management.
- Any further monitoring required by environment permit conditions.

### 20.2.3 Water Management

The high rainfall at Yandera requires high capacity drainage systems to reduce the amount of water that can encounter disturbed areas (such as the open pit, haul roads, and waste rock dump). The water management system for the mine will manage and, where necessary, treat water captured within the mine area. Surface water runoff will be captured and used to satisfy the processing and domestic use requirements, and treated as required to meet project water quality guidelines with the balance discharged to the local environment.

Overall, the system will aim to minimise the interception and/or contamination of surface and groundwater. Clean water will be diverted around surface works and, where practicable, intercepted (by dewatering) before it can enter the mine pits and other disturbed areas.

The Environment Act 2000 regulates discharges to the environment through the conditions on an environment permit. Conditions include a requirement to comply with legally enforceable water quality standards at a specified downstream compliance point and (for fresh and marine receiving waters) are contained in Schedule 1 of the PNG Environment (Prescribed Activities) Regulation 2002. Environment permits also contain conditions for the abstraction of surface water.

Where these standards do not specify limits parameters relevant to the Project, water quality guidelines from elsewhere will be used in the assessments carried out for the EIS and may include:

- Guidelines for Protection of Freshwater Aquatic Life Detailed in the Environmental Code of Practice for PNG's Mining Industry (OEC, 2000).
- Australia and New Zealand Environment and Conservation Council and Agriculture and Resource Management Council of Australia and New Zealand (ANZECC/ARMCANZ) Guidelines for Fresh and Marine Water Quality (ANZECC/ARMCANZ, 2000).
- Guidelines for Drinking Water Quality (WHO, 2011).

## 20.3 Potential Social or Community Requirements and Plans

Along with submission of an EIS, Section 51 of the Environment Act requires the likely social impacts of the proposed activity to be described in the EIS in accordance with aspects identified in the approved EIR. Two guidelines apply:

- DEC Guideline for the Conduct of Environmental Impact Assessment and Preparation of Environmental Impact Statement, Section 6 (DEC, 2004a).
- Draft Social Impact Assessment Guideline (DEC, 2004b).



Socio-economic information to be included in the EIS should comprise, but not be limited to:

- Demographic information.
- Information on existing infrastructure.
- Information on public health aspects.
- Present economic status of the project area.
- Existing social services availability.
- Details of archaeological, historical, cultural or religious features of the project area under consideration.

The EIS will address the socioeconomic impact assessment requirements through a social impact assessment (SIA). The SIA will include specialist studies to provide a comprehensive profile of the project area in relation to the human, social and economic environment and will include characterization studies, stakeholder engagement, specialist (field) studies and impact assessment (including management and mitigation measures).

The impact assessment will detail actual and perceived impacts of the Project and recommend mitigation strategies for potential negative impacts, including resettlement, and strategies to maximise potential social benefits arising from the Project. The approach to undertaking the socio-economic studies will be consistent with applicable PNG requirements and practice.

The draft SIA (Coffey, 2012) identified that the potential negative impacts of the Project (discussed in Section 1.94.2.2) can be minimized to an extent that they are outweighed by the potential benefits through:

- Careful planning by the project team.
- Robust community engagement.
- Ongoing coordination and planning with Government.
- Genuine partnerships with other appropriate development agencies (Government and non-Government).
- Effective implementation of management measures via a Social Management Plan and/or a Stakeholder Management Plan.

Example management measures that would be included in a Social Management Plan and/or a Stakeholder Management Plan include the following measures related to land and water use, in-migration and potential human health impacts:

- Where possible, relocating/redesigning project components to avoid and minimise damage to land and water resources.
- Implementing mitigation measures to manage water quality.
- Effectively managing chemicals/hazardous materials, controlling fire, weeds and pests, and managing general waste in and around the project area.
- Ensuring that communities near and downstream of project facilities are advised what mitigation and management measures will be implemented to manage their land and water resources.



- Where impacts to water sources cannot be avoided, providing alternative water resources.
- Developing and implementing a programme to monitor the impacts of the Project on downstream resource use.
- Establishing and implementing a Community Leadership Development Programme (CLDP) to build the capacity of affected communities to understand the potential impact of in-migration and develop their own coping strategies to self-mitigate against negative effects. The CLDP would include aspects of gender equality and human rights, as well as competition for jobs and natural resources, and would be the primary vehicle by which to achieve the informed consultation on in-migration potentially affecting affected communities.
- Negotiating with the local and provincial government to increase police presence in the mine and infrastructure area, if deemed necessary to mitigate in-migration impacts.
- Minimizing the potential impacts of communicable diseases related to in-migration by implementing:
  - Strategies to manage the impact of diseases through assessment, surveillance, actions plans, and monitoring.
  - A workplace programme to prevent new HIV infections and provide care and support for infected and affected employees. The workplace programme would include nutritional and HIV/AIDS education and awareness campaigns at accommodation camps and/or morning safety briefings, capitalizing on the 'captive' audience of a local workforce.
  - Outreach activities within the community, sector and/or broader society.
  - Local social infrastructure and services such as health and education, due to increased pressures from rapid population growth.
- Implementing a comprehensive stakeholder consultation programme which would include:
  - Regular and ongoing contact with village spokespersons.
  - Regular meetings with landowner executives.
  - Land access negotiations.
  - Land ownership resolution.
  - Negotiated compensation agreements.
  - Keeping communities fully briefed on project development.
  - Capacity building of Landowner Associations.
  - Implementation of a programme to prepare communities for future mining development.
  - Assessment of the impact of project design proposals on community.
  - Informing and briefing all levels of government on project design and development.
  - Facilitating government participation in community activities including awareness, land access negotiations, land ownership resolution, compensation agreement negotiations and verification and payment of compensation.



- Providing information on project design for government to assess and provide comment.
- Continually consulting with government and regulators.

There are no known pre-existing agreements or negotiations with local communities.

## **20.4 Required Permit and Status**

This section describes the approval and permitting requirements for the Project.

### **20.4.1 Papua New Guinea Legislation and Regulations**

The Mining Act 1992 and the Environment Act 2000, as described below primarily regulate the assessment, approval and development of the Project. Other environmental and social legislation and regulations applicable to the Project are also discussed.

#### **20.4.1.1 Mining Act 1992**

The Mining Act 1992 is the principal policy and regulatory document governing the mining approvals process in PNG and is administered by the Minerals Resources Authority (MRA). The act vests ownership of all minerals with the State and governs the exploration, development, processing and transport of minerals. The act is administered by the MRA.

The right to explore for, mine and sell minerals is conferred upon an applicant by the government through the grant of a tenement. Tenements are granted for a fixed term over a fixed area to persons or companies committed to a specific works or programme (of exploration or mining) approved by the government. Tenements are granted by the Minister for Mining. Each tenement entitles the holder to enter and occupy the land subject to conditions attached to the licence or lease.

Era holds two non-contiguous tenements in the form of exploration licences (EL): EL 1335 (Yandera) and EL 1854 (Lila/Cape Rigny). The total tenement package covers 269.39km<sup>2</sup>, with the EL 1335 containing the resource, and EL 1854 potentially hosting wharf infrastructure to support development. Era currently holds 100% ownership of the land tenements although the State reserves the right to purchase up to 30% equity interest in any mineral discovery arising from an EL.

Due to the scale and the capital expenditure associated with its development, the Project would be required to operate under a special mining lease (SML) which is generally issued to the EL holder for large-scale mining operations. The EL holder must also be a party to a Mining Development Contract with the state. An SML may be granted for a term not exceeding 40 years, which may be extended for periods not exceeding 20 years. The holder of an SML must pay a royalty to the State equivalent to 2% of the net proceeds of sale of minerals.

Before the grant of an SML, the Minister is required to convene a development forum to consider the views of the persons and authorities whom the Minister believes will be affected by the grant of the SML. The forum would include representatives from the applicant for the SML, affected landholders, and the national and provincial government.



An application for an SML requires a proposal for development typically includes the PFS, and a landownership study and other management plans. Prior to granting of a SML, the applicant must negotiate a Mining Development Contract with the State. Other licences/leases may also be required including:

- **Lease for mining purposes** for activities in connection with mining such as the construction of buildings and other infrastructure, treatment facilities, and the deposit of tailings.
- **Mining easement**, granted in connection with mining, treatment or ancillary operations conducted by the applicant for the mining easement for the purpose of constructing and operating a road, an aerial ropeway, a power transmission line, a pipeline, a conveyor system, a bridge or tunnel, a waterway, any other facility ancillary to mining or treatment or ancillary operations.

The term of both a lease for mining purposes and a mining easement would be identical to the term of the SML.

Affected landowners are entitled to compensation for mine-related disturbances that occur on their property. Prior to developing the mine, Era will be required to negotiate compensation with the local landowner association for landowners that would be affected.

In summary, the permitting and approval requirements under the act involve the following:

- Application for a SML, containing survey requirements and a proposal for development which typically includes:
  - Definitive Feasibility Study.
  - Landownership study.
  - Business development, supply and procurement plan.
  - Employment and training plan.
  - Negotiation of a mining development contract with the State.
  - Applications for lease for mining purposes and mining easement, as required.
  - Mining Warden’s hearings for all tenements applied for.
  - Negotiation of a compensation agreement with landowners.
  - Participation in a development forum with all levels of government and landowners to negotiate how the benefits of the Project will be distributed.
  - Signing of a memorandum of agreement with all participants in the development forum.

### 20.4.1.2 Environment Act 2000

The principal legislation for regulating the environmental effects of projects in PNG is the Environment Act 2000 (Environment Act). In February 2014, the PNG Government passed an Act to set up the Conservation and Environment Protection Authority (CEPA) as the government agency responsible for administering the Environment Act.



The Environment Act 2000 defines the environment to include ecosystems and their constituent parts including people and communities, natural resources, amenity, intrinsic and cultural values of a place.

The act requires a proponent to obtain an environment permit for activities prescribed in the Environment (Prescribed Activities) Regulations 2002 that have the potential to cause environmental harm. Activities are classified as Level 1, Level 2 or Level 3 based on their risk of causing environmental harm and each requires a different level of environmental and social assessment.

Level 3 activities, which include mining developments of the scale of the Project, have the highest risk of causing environmental harm. The grant of a Level 3 environment permit is subject to a comprehensive environmental impact assessment, presented in an environmental impact statement (EIS). The EIS is reviewed by CEPA in consultation with the public. The EIS must include assessment of reasonable alternatives to the Project and in particular will be required to present a credible assessment of both the on-land TSF and DSTP tailings disposal options.

The environmental impact assessment process will also be subject to amendments from the Environment (Amendment) Act 2014 once this statute comes into force. The key requirements of the EIS process under the Environment Act 2000 and the suggested amendments under the Environment (Amendment) Act 2014 include:

- Preparation and submission of an EIR.
- Preparation and submission of an EIS.
- A public review and referral phase.
- In-principle approval of the proposed activities by the Minister for Environment and Conservation.

The EIR for the Project was submitted to CEPA on 24 June 2016 (Coffey, 2016) and was approved on 2 August 2016. The report identified potential environmental and social aspects associated with the Project and described the scope of the EIS, including specialist technical studies that will be carried out.

The EIS should be prepared in accordance with the Guideline for Conduct of Environmental Impact Assessment and Preparation of Environmental Impact Statement (DEC, 2004a). The guideline requires the EIS to assess potential environmental and social impacts of the Project and to describe how the proponent intends to avoid, manage or mitigate these impacts. The EIS is submitted to the Director of Environment (the Director) who has 30 days to notify the proponent of the length of the assessment period.

The Director, while assessing the EIS, may refer the document to a number of bodies, such as an environmental consultant for peer review or a public inquiry committee. If a provincial environment committee has been established, the Director must refer the EIS to the committee for its comments.

The Director will accept the EIS if he or she is satisfied that the assessment contains an adequate description of the nature and extent of physical and social environmental impacts which are likely to result from the carrying out of the Project, that all reasonable steps will be taken to minimise environmental harm from carrying out the activity and that it will be undertaken in compliance with all relevant PNG environment policies and regulation.





After the preliminary assessment period, the Director will make the EIS available for public review and, during this time, Era may be required to make public presentations or submit a programme of public review and consultation. If the EIS is accepted, the Director must refer the decision to the Environment Council together with an assessment report and any public submissions. If the Environment Council were satisfied with the EIS within a 90-day review period, it would advise the Minister for Environment and Conservation to approve the proposed activity in principle. The proponent can then apply for a permit to carry out project activities.

Once approval of the EIS is granted in principle, Era will need to submit an application for an environment permit to CEPA for a Level 3 activity. The environment permit will include conditions of approval that may relate to:

- Installation of plant or equipment within a certain time.
- Taking certain action to minimise the risk of environmental harm.
- Installation of monitoring equipment.
- Preparation and implementation of an environmental management programme.
- Provision of reports specified by the Director.
- Environmental improvement plan.
- Audits.
- Emergency response.
- Provision of information required by the Director.
- Environmental bond.
- Baseline studies.
- Rehabilitation.

Part VII of the Act provides for permits for the use of water resources in PNG, including dams, diversions, and discharge of wastes and/or contaminants.

### 20.4.1.3 Other Relevant Legislation and Regulations

Other PNG acts and regulations that may be applicable to the Project are listed in Table 20-1:

**Table 20-1: Relevant Legislation and Regulations**

Title	Description
Fauna (Protection and Control) Act 1966	Provides for the protection, control, harvesting and destruction of fauna.
International Trade (Fauna and Flora) Act 1979	Regulates the export of species listed under the Convention on International Trade in Endangered Species of Wild Fauna and Flora.
Forestry Act 1991	Provides for the management, development and protection of forest resources and environments as a renewable asset.
National Water Supply and Sewerage Act 1986	Provides for the licencing of water supply and sewerage services.



Title	Description
Natural Cultural Property (Preservation) Act 1965 National Cultural Property (Preservation) Regulations 1965	Requires cultural heritage not be wilfully destroyed, damaged or defaced; consent for the export or removal of cultural heritage from PNG; and reporting to the National Museum and Art Gallery of particular cultural heritage finds.
War Surplus Materials Act 1952	Provides for the protection of relics derived from the World War II, along with the protection of historical period properties in the context of buildings, structures, monuments, burial places, shipwrecks and other materials of historical significance to PNG.
Cemeteries Act 1955	Controls and regulates cemeteries and burials, requires authority to be obtained prior to the exhumation of any burials including burials on private grounds.
Prevention of Pollution of the Sea Act 1979 Prevention of Pollution of the Sea Regulation 1980	Provides for the prevention and control of pollution of the sea by oil and other substances, wastes and dumping, liability, and compensation for pollution, and prevention, reduction and control of the introduction of harmful aquatic organisms and pathogens to PNG waters via ships ballast and water sediments.
Environment (Permits) Regulation 2002	Details the procedures for applications for, processing of, appeals against, and compliance with, environment permits.
Environment (Prescribed Activities) Regulation 2002	Details prescribed activities and their associated level of assessment. The Project involves Level 3 activities necessitating preparation of an EIS.
Environment (Water Quality Criteria) Regulation 2002	Provides enforceable water quality standards for a mixing zone boundary downstream of effluent discharge.
Public Health (Drinking Water) Regulation 1984	Provides enforceable standards for drinking water quality.
Environment (Fees and Charges) Regulation 2002	Details the fees and charges set by CEPA.

## 20.5 Mine Closure Requirements and Costs

This preliminary estimate of the closure and rehabilitation costs for the Project has been prepared to inform Era of its potential closure liability. The provision for a closure bond in PNG has rarely been enforced, and when applied, has been significantly less than the likely closure liability.

Mine closure planning (and therefore costing) will be a continuous process throughout the remainder of the PFS, DFS and EIS process throughout the life of the mine. As such, the costs presented here are based on the current project design and broad closure concepts and objectives for the site.



These objectives are:

- Ensuring that the site is safe and stable.
- Revegetating to improve visual aesthetics, promote long-term recovery of the soils and reduce restrictions on future land use.
- Reducing long-term environmental impacts and future liabilities.

The costs (and the Conceptual Mine Closure Plan to be included in the EIS) will need to be progressively refined and updated throughout the life of the mine to incorporate into the costs additional site information as it becomes available during construction and operations, any changes in mine operations, and any information gained from trials/progressive rehabilitation.

### 20.5.1 Calculating Rehabilitation Costs

Rehabilitation costs were calculated using a workbook based on the Australian Northern Territory Government security calculation procedure (DOR, 2007) and its associated security calculation spreadsheet (DOR, 2009), as well as estimated closure and rehabilitation unit rates prepared for other projects in PNG and other developing countries.

The costs are based on conceptual level information on:

- Closure domains.
- Reclamation, decommissioning and closure activities (e.g., backfilling, stabilization, flooding, and revegetation) applicable to each domain, including any assumptions made regarding these.
- Post closure management, monitoring and maintenance.

Domains were defined using the current project layout, footprint estimates and sediment pond volumes provided by Advisian. Definitions of the domains are presented in Table 20-2.

**Table 20-2: Domain Definitions**

ID#	Domain	Definition
1	Infrastructure	All roads that will not become public infrastructure, the mine and milling precinct, Cape Rigny flotation plant, Cape Rigny quarry access and the DSTP system (including overland slurry pipeline).
2	Pits	Mining area pits, Mt Wireless Quarry, Cape Rigny Quarry.
3	Sedimentation ponds	Includes the Dengru pond, Precinct pond, Gamagu pond, and 'other' ponds assumed at 5,000m <sup>3</sup> volume.
4	Waste rock dump	Waste rock dump.
5	Tailing storage facility (TSF)	A closure estimate for a TSF has not been included in the overall rehabilitation estimate, noting that DSTP is the preferred tailings management option.
n/a	Post closure	Site assessments, management and maintenance.
n/a	Post closure monitoring	Surface and groundwater monitoring.

The costs were prepared by applying unit rates required to rehabilitate different domains multiplied by area (m<sup>2</sup>) or volume (m<sup>3</sup>).



## 20.5.2 Assumptions and Considerations

### 20.5.2.1 General

General assumptions made for the estimation of closure costs are:

- Costs do not include a contingency.
- No requirement to return relocated villages at mine closure (if applicable).
- Certain roads are required for local access or will become part of the national public infrastructure and will be left after closure with no rehabilitation. Mine haul roads outside the mining footprint and the Cape Rigny Quarry access road will be rehabilitated.
- Exploration-related disturbance will be developed, or rehabilitated during operation.
- Revegetation includes the addition of a minimum of 10cm of topsoil to assist revegetation programme, seeding, planting and one application of fertiliser.

### 20.5.2.2 Infrastructure

Assumptions made about infrastructure for the estimation of closure costs are:

- All tanks will be removed.
- The mine and milling precinct including all workshops, sheds, small buildings and concrete pads will be removed.
- Mine haul roads outside of the mining footprint will be rehabilitated.
- Run of Mine (RoM) material will be fed through the plant prior to closure, so no RoM material removal is required, only rehabilitation of the footprint.
- The slurry pipeline, DSTP pipelines and mix tanks will be removed and mix tank area rehabilitated.
- All major infrastructure at the Cape Rigny Flotation Plant will be removed and the Cape Rigny Quarry access road will be rehabilitated.
- The Yandera and Cape Rigny camps, the wharf, all low-tension electrical services and all other access roads will become public infrastructure.

### 20.5.2.3 Pits

Assumptions made about the pits (mining area pits and the Mt Wireless and Cape Rigny quarries) for the estimation of closure costs are:

- Pits will be allowed to fill with water naturally post-closure and no backfilling is required.
- Pits will be stabilized during operation.
- Drilling and blasting of pit faces to make safe is not required.
- Bulk earthworks for the pit abandonment bund will be covered under mining costs.
- The volume of borrow and gravel pits has not been estimated as no details are available at this stage. When available, it will be prepared assuming that it is equal to the volume of concrete and sheeting required for construction.



#### **20.5.2.4 Sediment Dams**

Assumptions made about the sediment dams, ponds and other dams for the estimation of closure costs are:

- All ponds and dams are to be drained and backfilled, for safety purposes.
- Area to be revegetated includes the surface area of sediment dams and does not include the areas of the walls and embankments.
- All potentially contaminated ponds will be HDPE lined, so removing contaminated sediments is not required.
- Catchment bunds are not to be removed on closure.

Note that final footprints are not yet available for all sediment ponds so an estimated footprint area has been used to estimate the closure costs.

#### **20.5.2.5 Waste Rock Dumps**

Assumptions made for the waste rock dump for the estimation of closure costs are:

- The waste rock dump will be stabilized during operation.
- Waste rock dump capping costs are to be included in bulk earthwork costs.
- Topsoil is required for each of the waste rock dumps.

#### **20.5.2.6 TSF**

Closure costs for a TSF have not been included in the overall rehabilitation estimate as DSTP is the preferred tailings management option.

#### **20.5.2.7 Management and Monitoring**

Assumptions made for management and monitoring for the estimation of closure costs are:

- Closure management is 1 year and post closure management is 10 years.
- Monitoring includes 20 surface water and 30 groundwater monitoring sites.

#### **20.5.3 Costs**

The total preliminary estimated cost to close and rehabilitate the Yandera Project is USD 114,372,602. This estimate will be refined as further information becomes available during the DFS.

#### **20.5.4 TSF**

The EIS for the Project will be required to present a credible assessment of both the on-land TSF and DSTP tailings disposal options including a cradle-to-grave cost estimate for both. The TSF closure estimate below has therefore been included for comparative purposes.



If a TSF were to be used for the Project, a preliminary closure estimate can be made based on a previous (2012) description of the tailings management facility (TMF) with an anticipated total TMF footprint area for Year 20 of 129.50 ha, of which 22 ha would be submerged by tailings, leaving 107.50 ha (1,075,000m<sup>2</sup>) to be rehabilitated. The TMF would include a 300m tall TSF/WRD embankment (containment dam), comprised NAF waste rock and filled with PAF rock and tailings.

A preliminary estimated cost to close and rehabilitate a TSF (as described above) for the Project is USD 5 762,162.





## 21 Capital and Operating Costs

### 21.1 Capital Cost Estimate

Herewith a summary of the estimated cost broken down per Work Breakdown Structure (WBS) level 2 for the Direct Cost Capital Estimate:

**Table 21-1: Summary of Estimated Cost broken down per WBS**

Description	Project (excl. National Infrastructure) (USD Million)	Project (excl. Mining Fleet) (USD Million)	All Inclusive Estimate (USD Million)
National Infrastructure	0	197	197
Mining	335	335	657
Yandera Precinct	292	305	305
Milling Plant to Coastal Facilities	212	305	305
Coastal Facilities	92	184	184
<b>Total</b>	<b>930</b>	<b>1,128</b>	<b>1,450</b>

### 21.2 Estimate Criteria

#### 21.2.1 Capex Estimate Base Date and Currency

The base date for this Capex Estimate is Quarter 4 2017, with the base currency being US Dollars. Prices obtained in other currencies were converted to US Dollars using the rate of exchange as indicated in the Capex Estimate. As the pricing is based on a base date of Quarter 4 2017, and no inflation increases are expected for the last 2months of 2017, the base date for pricing can be stated as Quarter 1 2018.

No allowances were made in the Capex Estimate for Forex fluctuations. For any Forex fluctuations, we have assumed these have been catered for in the financial model sensitivity analysis.

#### 21.2.2 Required and Achieved Accuracy of Capex Estimate

The Capex Estimate for this Project has been developed to a pre-feasibility level of accuracy (i.e. a target range of -25% to -15%). Advisian conducted an accuracy assessment to determine whether the required level of accuracy has been achieved for this Capex estimate.

The criteria ranges, which have been applied to each item within the estimate, are illustrated in the table below:



**Table 21-2: Criteria Ranges**

Description	Poor	Average	Good
<b>FACTORING</b>			
Capacity factoring	+50% : -30%	+30% : -20%	+20% : -10%
Equipment factoring	+50% : -30%	+30% : -20%	+20% : -10%
Parametric factoring	+50% : -30%	+30% : -20%	+20% : -10%
Undefined factoring	+50% : -30%	+30% : -20%	+20% : -10%
<b>QUANTIFICATION</b>			
Global quantification	+50% : -30%	+30% : -25%	+20% : -20%
Prelim Equipment Lists	+30% : -18%	+23% : -12%	+16% : -6%
Final Equipment Lists	+18% : -6%	+12% : -4%	+5% : -2%
Prelim BQ's (measured)	+30% : -18%	+23% : -12%	+16% : -6%
Final Enquiry BQ's (measured)	+18% : -6%	+12% : -4%	+5% : -2%
Material Take-off Allowances	+18% : -6%	+12% : -4%	+5% : -2%
Undefined Quantification	+50% : -30%	+50% : -30%	+50% : -30%
<b>PRICING</b>			
Historical Database Costs	+50% : -30%	+30% : -23%	+20% : -16%
Estimating Models	+50% : -30%	+30% : -23%	+20% : -16%
Informal/Telephonic Quotes	+50% : -30%	+30% : -23%	+20% : -16%
Benchmark Costs	+50% : -30%	+30% : -23%	+20% : -16%
Single Budget Prices (Market)	+30% : -18%	+23% : -12%	+16% : -6%
Firm Tender Prices (Market)	+18% : -6%	+12% : -4%	+5% : -2%
Formal Budget Quotations	+18% : -6%	+12% : -4%	+5% : -2%
Provisional Sum Allowances	+50% : -30%	+30% : -23%	+20% : -16%
Undefined Pricing	+50% : -30%	+30% : -23%	+20% : -16%

The table below indicates the results achieved for the accuracy assessment for the Yandera Copper Project.

**Table 21-3: Results Achieved for Accuracy Assessment**

Stochastic Estimation					
Factoring	Estimate Total (USD Million)	Low Amount (USD Million)	High Amount (USD Million)	High	Low
Parametric factoring	101	81	131	-20.00%	+30.00%
Undefined factoring	14	10	21	-29.29%	+48.57%
<b>Grand Total</b>	<b>115</b>	<b>90</b>	<b>152</b>	<b>-21.13%</b>	<b>32.27%</b>

Deterministic Estimation					
Quantification	Estimate Total (USD Million)	Low Amount (USD Million)	High Amount (USD Million)	High	Low
Material Take-off Allowances	23	21	25	-5.51%	+11.48%
Prelim BQs (measured)	1,179	1,053	1,403	-10.74%	+18.92%
Prelim Equipment Lists	134	127	150	-5.23%	+12.39%
<b>Grand Total</b>	<b>1,336</b>	<b>1,201</b>	<b>1,578</b>	<b>-10.10%</b>	<b>18.14%</b>



Pricing	Estimate Total (USD Million)	Low Amount (USD Million)	High Amount (USD Million)	High	Low
Benchmark Costs	824	719	989	-12.71%	+20.04%
Firm Tender Prices (Market)	125	120	138	-3.86%	+10.23%
Single Budget Prices (Market)	387	361	451	-6.57%	+16.66%
<b>Grand Total</b>	<b>1,336</b>	<b>1,201</b>	<b>1,578</b>	<b>-10.10%</b>	<b>18.14%</b>

Estimating Methodologies Summary					
Description	Estimate Total (USD Million)	Low Amount (USD Million)	High Amount (USD Million)	High	Low
Deterministic	1 336	1,201	1,578	-10.10%	+18.14%
Stochastic	115	90	152	-21.13%	+32.27%
<b>Grand Total</b>	<b>1,450</b>	<b>1,291</b>	<b>1,730</b>	<b>-10.98%</b>	<b>19.26%</b>

The result of the above accuracy assessment is that overall the estimate accuracy is calculated at +19.29% to -10.98 % for the Yandera Copper Project (before others) consider any contingency

It should however be noted that this assessment is subjective and the view of the Estimator based on the input information received and the applied accuracy range parameters detailed in Table Accuracy Range Parameters above

### 21.2.3 Project Scope of Work

The scope of Work for the Yandera Copper Project includes the following:

- Mining.
- Yandera Precinct.
- Yandera Precinct to Flotation Plant.
- Coastal Facilities.

### 21.2.4 Scope of Capex Estimating Preparation

Advisian was responsible to compile the Direct Cost Capex Estimate with information received from various sources and stakeholders as defined in detail in this document. As part of the Capex estimate Advisian compiled the following deliverables:

- Capex estimate in Excel Data Base format in Constant Money Terms.
- Cost flows and escalation forecast calculations.
- Detailed accuracy assessment.
- Detailed basis of estimate.



### 21.2.5 Foreign Currency and Exchange Rates

No allowances were made in the Capex Estimate for Forex fluctuations. For any Forex fluctuations, we have assumed these have been catered for in the financial model sensitivity analysis.

### 21.2.6 Estimating System and Format

The Capex estimate was prepared using MS Excel 2016 and is presented in MS Excel 2016 format making use of a flat data base structure. From this flat database, it was possible to generate pivot tables reflecting the cost as per WBS area and per discipline. With the pivot table being versatile, it enables various types of reports to be generated i.e. cost per discipline, per area etc.

### 21.2.7 Constraints and Exclusions

The list below reflects the currently identified constraints and exclusions that are pertinent to the Capex Estimate:

- Allowances for special incentives (schedule or others).
- Deferred capital costs.
- Force majeure issue.
- Opex costs.
- Owners and consultant's costs for execution phase as well as for future study phases.
- Sunk costs.
- Future scope changes.
- Mine closure and rehabilitation.
- Costs associated with removal of unexploded ordnance.
- Flooding delay costs or resulting construction labour stand down costs.
- Management of injuries and return to work beyond the project duration.
- Interest on capital loans.
- Taxes and duties.
- Foreign currency fluctuations.
- Foreign exchange cover.
- Standing costs.
- Project insurance cost.
- Design work completed to date.
- Carbon taxes.
- Escalation provisions.
- Contingency provisions.



## 21.3 Estimating Methodologies

This section outlines the estimating methodology adopted by Advisian.

### 21.3.1 Overall Philosophy

The general estimating philosophy that was utilized to determine the direct cost of this option was using Deterministic (measurement) estimating techniques.

This Capex Estimate was prepared in MS Excel as a flat database by Advisian.

### 21.3.2 Technical Basis

The following technical information was used by Advisian to complete the Capex estimate:

- Plot plans.
- Process Flow Diagrams (PFDs).
- Priced estimate from BRASS for the supply and installation of the slurry pipeline as well as the DSTP system.
- Conveyor mechanical equipment lists.
- Conveyor profile arrangement drawings.
- Civil design drawings.
- Piping line lists.
- Various bills of quantities from the Engineer.
- Project scope description.



### 21.3.3 Cost and Accuracy per Area

The following graphic illustration represents the major WBS areas and cost allocations (millions):

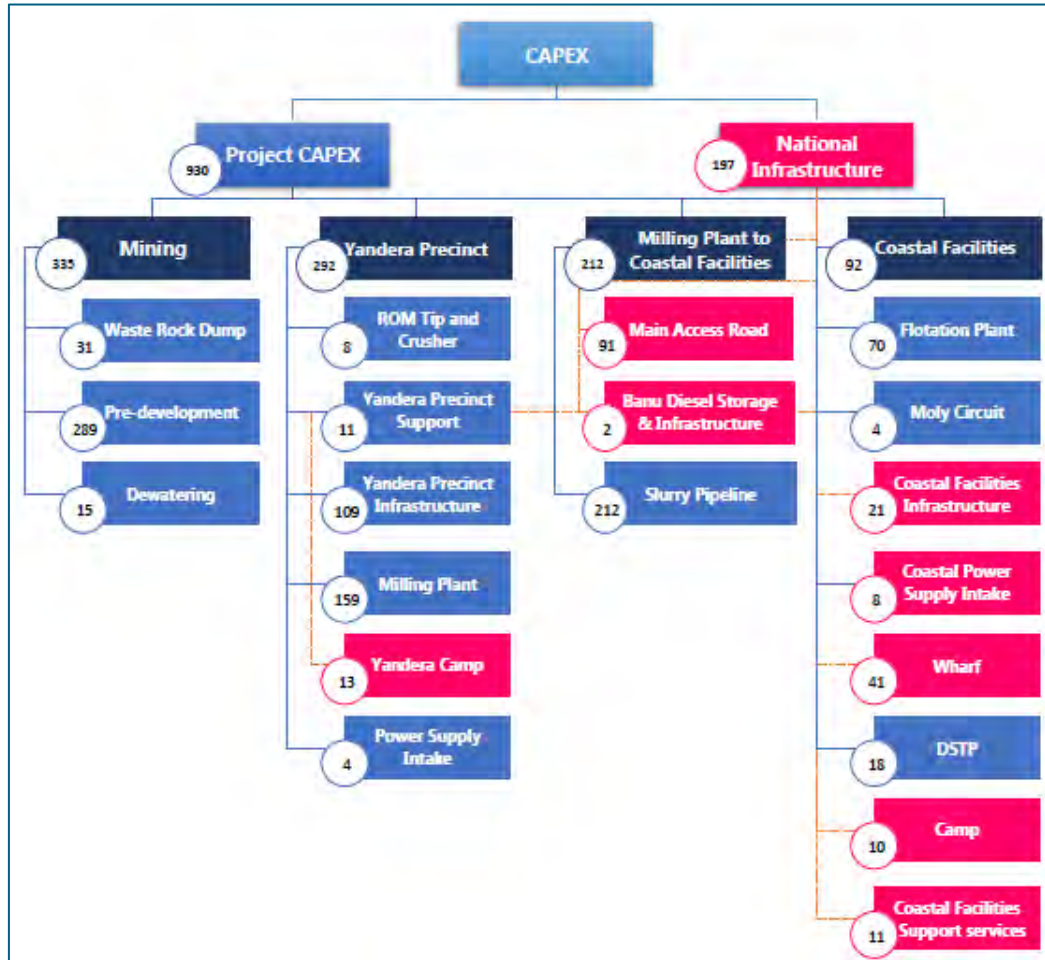


Figure 21-1: Major WBS Areas and Cost Allocations (millions)

#### 21.3.3.1 Mining

The Mining area total Capex Estimate amount of USD657million within an accuracy range of - 9.50% +18.65%, resulting in a ranged estimate from a low range of USD595million to an upper range of USD780million.

Table 21-4: Mining Capex Estimate Breakdown

Description	Estimate Total (USD Million)	Low Amount (USD Million)	High Amount (USD Million)	High	Low
Waste Rock Dump	31	27	36	-11.00%	+18.00%
Pre-Development	289	259	342	-10.38%	+18.33%
Dewatering	15	11	22	-28.20%	+46.80%
Mine Development	0	0	0	-	-
Mining Fleet	322	298	380	-7.71%	+17.71%
<b>Grand Total</b>	<b>657</b>	<b>595</b>	<b>780</b>	<b>-9.50%</b>	<b>18.65%</b>





The estimating methodology split for the mining section is illustrated in the table below.

**Table 21-5: Estimating Methodology Split for Mining Section**

Description	Estimate Total (USD Million)	Low Amount (USD Million)	High Amount (USD Million)	High	Low
Deterministic	598	549	701	-8.25%	+17.09%
Stochastic	59	46	79	-22.21%	+34.41%
<b>Grand Total</b>	<b>657</b>	<b>595</b>	<b>780</b>	<b>-9.50%</b>	<b>18.65%</b>

### 21.3.3.2 Yandera Precinct

The Yandera Precinct area total Capex Estimate amount of USD 305million within an accuracy range of -10.75% +18.41%, resulting in a ranged estimate from a low range of USD272million to an upper range of USD 361million.

**Table 21-6: Estimating Split for Yandera Precinct**

Description	Estimate Total (USD Million)	Low Amount (USD Million)	High Amount (USD Million)	High	Low
ROM Tip and Crusher	8	7	9	-9.82%	+17.26%
Yandera Precinct Support Services	11	10	14	-13.96%	+21.87%
Yandera Precinct Infrastructure	114	100	136	-11.88%	+19.75%
Milling Plant	154	139	181	-9.83%	+17.42%
Yandera Camp	13	12	15	-8.41%	+15.05%
Power Supply Intake Sub-station	4	4	5	-14.00%	+21.50%
<b>Grand Total</b>	<b>305</b>	<b>272</b>	<b>361</b>	<b>-10.75%</b>	<b>18.41%</b>

The estimating methodology split for the Yandera Precinct section is illustrated in the table below.

**Table 21-7: Estimating Methodology Split for Yandera Precinct Section**

Description	Estimate Total (USD Million)	Low Amount (USD Million)	High Amount (USD Million)	High	Low
Deterministic	264	239	308	-9.32%	+16.62%
Stochastic	41	33	53	-20.00%	+30.00%
<b>Grand Total</b>	<b>305</b>	<b>272</b>	<b>361</b>	<b>-10.75%</b>	<b>18.41%</b>



### 21.3.3.3 Milling Plant to Coastal Facilities

The Milling Plant to Coastal Facilities area total Capex Estimate amount of USD 305million within an accuracy range of -13.09% +20.44%, resulting in a ranged estimate from a low range of USD 265million to an upper range of USD 363million.

**Table 21-8: Estimating Split for Milling Plant to Coastal Facilities**

Description	Estimate Total (USD Million)	Low Amount (USD Million)	High Amount (USD Million)	High	Low
Main Access Road	91	81	107	-11.00%	+18.00%
Banu Diesel Storage & Infrastructure	2	2	3	-10.86%	+18.49%
Slurry Pipeline	212	182	258	-14.00%	+21.50%
<b>Grand Total</b>	<b>305</b>	<b>265</b>	<b>367</b>	<b>-13.09%</b>	<b>20.44%</b>

The estimating methodology split for the milling plant to coastal facilities section is illustrated in the table below.

**Table 21-9: Estimating Methodology Split for Milling Plant to Coastal Facilities Section**

Description	Estimate Total (USD Million)	Low Amount (USD Million)	High Amount (USD Million)	High	Low
Deterministic	304	265	367	-13.07%	+20.42%
Stochastic	1	0	1	-20.00%	+30.00%
<b>Grand Total</b>	<b>305</b>	<b>265</b>	<b>367</b>	<b>-13.09%</b>	<b>20.44%</b>

### 21.3.3.4 Coastal Facilities

The Coastal Facilities area total Capex Estimate amount of USD 184million within an accuracy range of -13.15% +20.92%, resulting in a ranged estimate from a low range of USD 159million to an upper range of USD 222million.

**Table 21-10: Estimating Split for Coastal Facilities**

Description	Estimate Total (USD Million)	Low Amount (USD Million)	High Amount (USD Million)	High	Low
Flotation Plant	70	62	84	-11.71%	+19.18%
Mo Circuit	4	4	5	-8.54%	+15.88%
Coastal Facilities Infrastructure	21	18	24	-11.71%	+18.85%
Coastal Power Supply Intake Sub-station	8	7	10	-14.97%	+23.58%
Wharf	41	34	51	-16.82%	+25.61%
DSTP	18	15	22	-14.00%	+21.50%
Camp	10	10	12	-9.35%	+16.12%



Description	Estimate Total (USD Million)	Low Amount (USD Million)	High Amount (USD Million)	High	Low
Coastal facilities Support services	11	10	14	-13.96%	+21.87%
<b>Grand Total</b>	<b>184</b>	<b>159</b>	<b>222</b>	<b>-13.15%</b>	<b>20.92%</b>

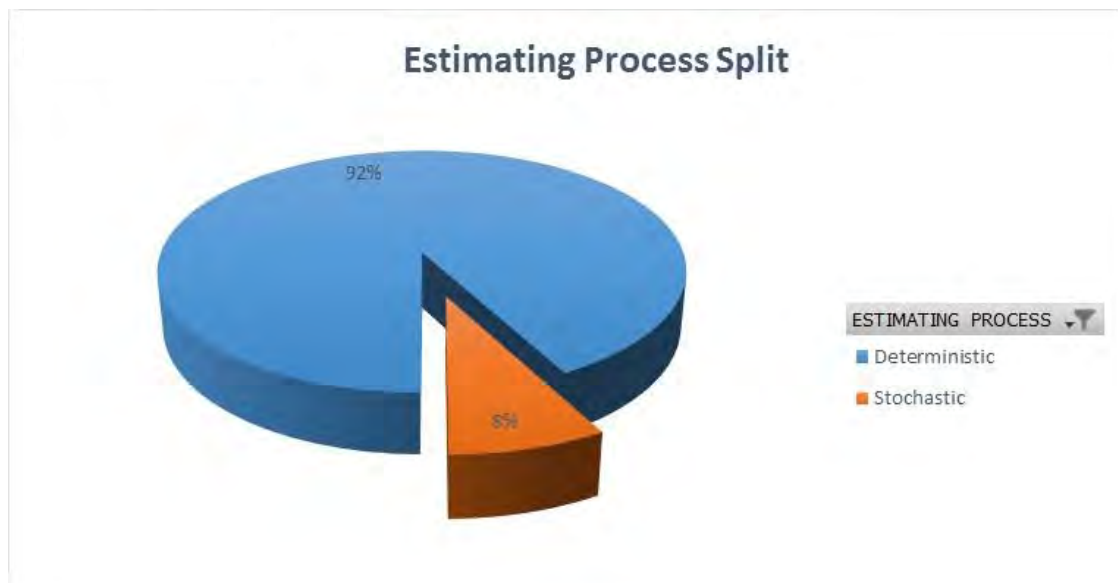
The estimating methodology split for the milling plant to coastal facilities section is illustrated in the table below:

**Table 21-11: Estimating Methodology Split for Coastal Facilities Section**

Description	Estimate Total (USD Million)	Low Amount (USD Million)	High Amount (USD Million)	High	Low
Deterministic	169	148	203	-12.56%	+20.13%
Stochastic	15	12	19	-20.00%	+30.00%
<b>Grand Total</b>	<b>184</b>	<b>159</b>	<b>222</b>	<b>-13.15%</b>	<b>20.92%</b>

### 21.3.4 Overall Estimating Methodology

The overall analysis of the Capex estimate concerning the estimating methodologies is as follows:



**Figure 21-2: Estimating Process Split**

## 21.4 Assumptions

It is assumed that the detail provided by Advisian is a true reflection of the specific scope of work portions. In addition, that the interface between all service providers has been adequately addressed as this information is the basis for the quantification of the PFS.



## **21.5 Estimating Methodologies – Yandera Copper Project**

### **21.5.1 Waste Rock Dump**

#### **21.5.1.1 Quantification**

The quantities were compiled in a bill of quantities format.

#### **21.5.1.2 Pricing**

The Direct Cost Capex Estimate for the Waste Rock Dump has been compiled from benchmark prices obtained from internal database sources for a similar project in PNG.

The bills of quantities were issued to market for pricing to several contractors, however no responses were received, with bidders stating currently workload as the major reason for declining to tender.

### **21.5.2 Haul Roads**

#### **21.5.2.1 Quantification**

The quantities were compiled in a bill of quantities format.

#### **21.5.2.2 Pricing**

The Direct Cost Capex Estimate for the Waste Rock Dump has been compiled from benchmark prices obtained from internal database sources from Worley Parsons for a similar project in PNG.

The bills of quantities were issued to market for pricing to several contractors, however no responses were received, with bidders stating currently workload as the major reason for declining to tender.

### **21.5.3 Fleet**

#### **21.5.3.1 Quantification**

The quantities were compiled in a bill of quantities format.

#### **21.5.3.2 Pricing**

The Direct Cost Capex Estimate for the Fleet has been compiled from a combination of benchmark prices obtained from internal database sources from Worley Parsons for a similar project in PNG as well as from budget quotation received from the market.

The requests for quotation were issued to market for pricing to several suppliers, however a lower response ratio was received, with bidders stating currently workload and no local support office as the major reasons for declining to tender.



## **21.5.4 Roads**

### **21.5.4.1 Quantification**

The quantities were compiled in a bill of quantities format.

### **21.5.4.2 Pricing**

The Direct Cost Capex Estimate for the Sedimentation Ponds has been compiled from benchmark prices obtained from internal database sources from Advisian for a similar project in PNG.

The bills of quantities were issued to market for pricing to several contractors, however no responses were received, with bidders stating currently workload as the major reason for declining to tender

The access roads will be owner built; therefore, ancillary fleet has been included in the estimate of the roads. The construction indirect costs have been assumed to be allowed for in the Opex estimate.

## **21.5.5 Bulk Earthworks**

### **21.5.5.1 Quantification**

The quantities were compiled in a bill of quantities format.

### **21.5.5.2 Pricing**

The Direct Cost Capex Estimate for the Bulk Earthworks has been compiled from benchmark prices obtained from internal database sources from Advisian for a similar project in PNG.

The bills of quantities were issued to market for pricing to several contractors, however no responses were received, with bidders stating currently workload as the major reason for declining to tender.

## **21.5.6 Sedimentation Ponds**

### **21.5.6.1 Quantification**

The quantities were compiled in a bill of quantities format.

### **21.5.6.2 Pricing**

The Direct Cost Capex Estimate for the Sedimentation Ponds has been compiled from benchmark prices obtained from internal database sources from Advisian for a similar project in PNG.

The bills of quantities were issued to market for pricing to several contractors, however no responses were received, with bidders stating currently workload as the major reason for declining to tender.



## **21.5.7 Civil Works**

### **21.5.7.1 Quantification**

The bulk quantities were compiled and factors were then applied from a similar project to ascertain the bill of quantities.

### **21.5.7.2 Pricing**

The Direct Cost Capex Estimate for the Civil Works has been compiled from benchmark prices obtained from internal database sources from Advisian for a similar project in PNG.

The bills of quantities were issued to market for pricing to several contractors, however no responses were received, with bidders stating currently workload as the major reason for declining to tender.

## **21.5.8 Structural Steelwork**

### **21.5.8.1 Quantification**

The bulk quantities were issued by engineers and factors were then applied from a similar project to ascertain the bill of quantities.

### **21.5.8.2 Pricing**

The Direct Cost Capex Estimate for the Structural Steelwork has been compiled from benchmark prices obtained from internal database source for a similar project in PNG as well as an internal database source from similar project (both size and complexity).

The bills of quantities were issued to market for pricing to several contractors, however no responses were received, with bidders stating currently workload as the major reason for declining to tender.

## **21.5.9 Platework**

### **21.5.9.1 Quantification**

The platework items were extracted from the Mechanical Equipment schedule issued by the engineers.

### **21.5.9.2 Pricing**

The Direct Cost Capex Estimate for the Platework has been compiled from benchmark prices obtained from internal database source for a similar project in PNG as well as Advisian's internal database sources from similar project (both size and complexity).

The bills of quantities were issued to market for pricing to several contractors, however no responses were received, with bidders stating currently workload as the major reason for declining to tender.





## **21.5.10 Piping, Fittings and Valves**

### **21.5.10.1 Quantification**

The quantities were compiled in a bill of quantities format.

### **21.5.10.2 Pricing**

The Direct Cost Capex Estimate for the Piping, Fittings and Valves has been compiled from benchmark prices obtained from internal database source for a similar project in PNG as well as Advisian's internal database sources from similar project (both size and complexity).

The bills of quantities were issued to market for pricing to several contractors, however no responses were received, with bidders stating currently workload as the major reason for declining to tender.

## **21.5.11 Mechanical Equipment**

### **21.5.11.1 Quantification**

The mechanical equipment items were extracted from the Mechanical Equipment schedule issued by Advisian.

### **21.5.11.2 Pricing**

The Direct Cost Capex Estimate for the Electrical Equipment has been compiled from a combination of benchmark prices obtained from internal database sources from Advisian for a similar project in PNG as well as Advisian's internal database sources from similar project (both size and complexity) as well as budget quotations received from the market.

The requests for quotation were issued to market for pricing to several contractors, however a low return ratio in responses was received, with bidders stating currently workload as the major reason for declining to tender.

## **21.5.12 Electrical Equipment**

### **21.5.12.1 Quantification**

The electrical equipment items were extracted from the correspondence received from Advisian.

### **21.5.12.2 Pricing**

The Direct Cost Capex Estimate for the Electrical Equipment has been compiled from a combination of benchmark prices obtained from internal database sources from Advisian for a similar project in PNG as well as Advisian's internal database sources from similar project (both size and complexity) as well as budget quotations received from the market.

The requests for quotation were issued to market for pricing to several contractors, however a low return ratio in responses was received, with bidders stating currently workload as the major reason for declining to tender.



## **21.5.13 Electrical Installation**

### **21.5.13.1 Quantification**

The quantities were compiled in a bill of quantities format.

### **21.5.13.2 Pricing**

The Direct Cost Capex Estimate for the Electrical Installation budget quotations received from the market.

## **21.5.14 Instrumentation**

### **21.5.14.1 Quantification**

The Advisian Engineer advised that the instrumentation should be factored from the mechanical equipment supply cost at a ratio of 7.5%. Furthermore, the area split was indicated as follows:

▪ Mining	7.5%
▪ Yandera Precinct	15.0%
▪ Milling Plant to Coastal Facility	57.5%
▪ Coastal Facilities	20.0%

### **21.5.14.2 Pricing**

This was factored from the priced mechanical equipment.

## **21.5.15 Wharf**

### **21.5.15.1 Quantification**

The quantities were compiled in a bill of quantities format.

### **21.5.15.2 Pricing**

The pricing was obtained from the Advisian engineers

## **21.5.16 Deep Sea Tailings Disposal**

### **21.5.16.1 Quantification**

BRASS engineers in a bill of quantities format issued the quantities.

### **21.5.16.2 Pricing**

BRASS engineers in a bill of quantities format issued the quantities.



## **21.5.17 Owners Cost and Engineering Consultant Costs**

No allowances have been made for owner's costs or consultant costs as instructed by the Client Representative.

## **21.6 Inputs to Capex Estimating**

The following inputs were received from others, which were used to complete the Capex Estimate to the targeted accuracy level. All information as listed in Section 8:

- Project Quantification Description – General.
- Plant Location – General.
- Integrated Project Plan.
- Project Master Schedule.
- Work Breakdown Structure.
- Plot Plans.
- Process Flow Diagrams (PFDs).

## **21.7 Cash Flow, Escalation and Forex Fluctuations**

### **21.7.1 Cash Flow Model**

The project cash flow model has been derived from the construction schedule applied to the Overall Project Areas. This has assumed a linear extrapolation of the total costs per area.

### **21.7.2 Project Escalation Calculation Results**

Escalation is provided for in the financial model.

### **21.7.3 Cash Flow and Escalation Exclusion**

- Time Lag impact on cost.
- Cost and Schedule Overruns.
- Change Orders.
- Contract Conditions.
- Payment Terms.

### **21.7.4 Forex Rates**

The following foreign currency exchange rates have been used in the preparation of the Capital Direct Cost Estimate.



**Table 21-12: Forex Exchange Rates used to prepare Capital Direct Cost Estimate**

Currency Code	Currency Description	ROE
-	Base Currency	-
ZAR	South African Rand	0.07
USD	United States Dollar	1.00
EUR	Euro	0.83
AUD	Australian Dollar	0.79
PGK	Papua New Guinean Kina	0.31
NZD	New Zealand Dollar	0.72

### 21.7.5 Capex of Ore Slurry Pipeline

Table 21-13 summarizes the capital cost estimate developed for the proposed ore slurry pipeline system. The scope of this estimate starts at the feed of the Inlet Station and ends at the outlet of the pipeline terminal holding tanks.

**Table 21-13: Ore Slurry Capital Cost Summary**

Component	Capital Cost (USD)
<b>Direct Cost</b>	<b>204,101,196</b>
<b>Equipment and Materials</b>	<b>126,217,329</b>
Pipeline Materials	90,454,355
Station equipment and materials	35,762,974
<b>Construction</b>	<b>77,883,867</b>
Pipeline construction	70,192,000
Station construction	7,691,867
<b>Indirect Cost</b>	<b>60,371,363</b>
Foreign Contractor Tax	7,998,444
<b>Total Slurry Capital Cost</b>	<b>212,099,640</b>

### 21.7.6 Capex of DSTP System

The estimated capital cost for the DSTP system is USD17.87million. The cost breakdown is shown in Table 21-14.

**Table 21-14: DSTP Capital Cost Summary**

Component	Capital Cost (USD)
Equipment and Materials	8,603,544
On-shore Construction	2,210,600
Off-shore Construction	6,797,000
Construction	256,000
<b>Direct Cost</b>	<b>17,867,144</b>



## **21.8 Operating Cost Estimate**

### **21.8.1 Basis of Estimation**

#### **21.8.1.1 Costing Model**

An activity-based cost model was developed to determine the working cost from first principles. The activity-based costing model uses the mine and process design criteria and production schedule inputs to derive cost rates for mining, processing and engineering activities. The derived rates are used in the model, which is driven by the production schedule to obtain the overall operating cost.

#### **21.8.1.2 Costing Base Date**

The cost estimations that form the building blocks of the operating cost model were sourced over a period of a few months during the 2017 calendar year. Additional operating costs were obtained from the relevant sub-contractors employed during the course of the Project.

#### **21.8.1.3 Activity-based Costing**

Activity-based costing is a methodology that builds costs up from all main activities and activities that constitute a process or operation. Costs are driven by their applicable cost drivers to simulate the process of individual activities, incurring costs as they are planned in the production schedule. In the model, six main activities build up the total operating cost. These activities are:

- Mining.
- Yandera Precinct.
- Milling Plant.
- Mill to Coastal Facilities.
- Coastal Facilities.
- General and Administration.

Each of these main activities consists of defined activities for which individual cost drivers are defined.

#### **21.8.1.4 Cost Elements**

The costs for the activities are driven by their defined cost drivers and are broken up into certain cost elements, which include but is not limited to the following:-

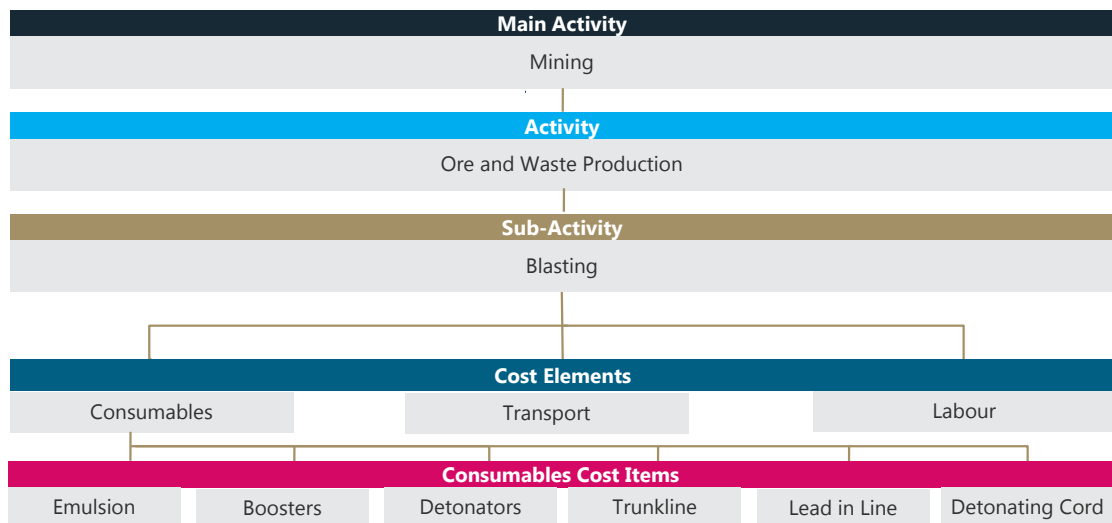
- Labour.
- Power.
- Fuel.
- Explosives.
- Maintenance and repairs.
- Ownership cost.



- Reagents and consumables.
- Contractors.
- Miscellaneous/other.

These cost elements are broken down into items, which make up the relevant costs such as renewals and repair. For example, mining as a main activity has an activity defined as ore mining. Ore mining costs are driven by ore tonnes produced and include the cost elements discussed above to perform that activity. These cost elements are made up of all the items fitting that description.

An example of these cost categorization relationships are illustrated in Figure 21-3.



**Figure 21-3: Cost Structure Example**

Costs are defined in terms of specific areas, namely ore mining, waste mining and total operation. The costs are combined to calculate the total cost of the operation.

### 21.8.2 Structure of Estimate

The mining estimate is structured to report on the defined cost elements per ore or waste tonne produced while the processing estimate is structured to report on the defined cost elements per ore tonne milled. The information and data used as the basis of the estimate are discussed in this section.

The main contributors to the direct mining cost are the following: drilling, blasting, loading, hauling, labour and engineering equipment. The main contributors to the direct processing cost are the reagents and consumables, power, maintenance, labour and engineering equipment. The assumptions and inputs considered to estimate the operating costs for these activities are detailed in the following sections.





The advantages and importance of determining costs from first principles and then crosschecking them are:

- Costs can be developed for any mining and processing equipment, not just equipment already in use on the mine or processing site.
- There is consistency between costs and estimation assumptions used and this consistency can be checked, or the assumptions modified, to generate a rough indication of cost sensitivity or assumption risks.

### 21.8.2.1 Labour Rates

The labour cost was calculated at contractor-operator rates. Advisian sourced in-house information sourced from PNG labour broker to determine the current local PNG and expatriate (“expat”) rates based on the Paterson grading system. The Paterson grading applied is illustrated in Table 21-15.

**Table 21-15: Paterson Grading – Labour Rates per Month**

Grade	Role	Local	Expats
		USD/month	USD/month
A0 Support	General Hand/ Labourer	356	
A0 Technical		410	
B1 Support	Operator L1, Admin Assistant/ Clerk/ Trainee	492	
B1 Technical		519	
B2 Support	Officer / Operator L2-3, Qualified Tradesman	875	7,688
B2 Technical		929	10,915
C3 Support	Graduate/ Senior Officer/ Operator L4/ Leading Hand	1,475	8,099
C3 Technical		1,531	8,992
C4 Support	Professional/ Supervisor	2,869	9,610
C4 Technical		3,060	11,463
D5 Support	Coordinator/ Snr Professional/ Foreman	3,880	11,670
D5 Technical		4,481	13,248
D6 Support	Superintendent/ Lead/ Principal	4,918	13,317
D6 Technical		5,684	17,160
E7 Support	Manager	7,323	19,838
E7 Technical		10,929	21,759
E8 Support	Group Manager	8,197	26,084
E8 Technical		12,022	27,457
F9 Support	General Manager	9,837	27,457
F9 Technical		13,224	30,203



## 21.8.2.2 Remuneration

The labour rates applied to the study reflects a total cost to company, which includes all cash and contributions to employee benefits such as pension, medical, group life, housing allowances, local transport and communications. Excluded are job related payments such as shift allowances or variable pay such as fly-in-fly-out travel costs, share schemes and short and long-term incentives. The labour estimate included an un-available allowance whereby the labour requirement was adjusted, as shown in Table 21-16 below.

**Table 21-16: Unavailable Allowances**

Description	Unavailable Allowance
Leave %	8%
Sick %	1%
Training %	3%
<b>Total</b>	<b>12%</b>

The additional compensation for local and expatriate personnel is shown in Table 21-17.

**Table 21-17: Additional Compensation**

Description	Personnel	Percentage
Overtime	Local & Expatriate	5%

## 21.8.3 Mining Operating Cost

### 21.8.3.1 Introduction

Mining operating costs relate to open pit ore and waste mining and materials handling of the ore to the mining precinct where the mill is situated and hauling of the waste to the waste rock dump. The mining estimate is structured to report on the defined cost elements per ore or waste tonne produced. The information and data used as the basis of the estimate are discussed in this section.

The main contributors to the direct mining cost are the following:

- Drilling.
- Blasting.
- Loading.
- Hauling.
- Auxiliary services.
- Pit dewatering.
- Grade control drilling.
- Fixed costs.

Where possible, vendor quotations were used to build up the unit rates. In the absence of vendor data, current operating costs were sourced.



### 21.8.3.2 Contractor Mining

Starting a new, mine in a remote area presents challenges to mining companies; often the local labour pool lacks the skills required to operate large specialized equipment. Contractors offer the ability to quickly deploy and supply skilled, trained, and experienced personnel from their internal human resource pool to remote locations and to support the transfer of mining skills to local personnel.

The contractor should source local people and only employ expatriate labour if the skill is unavailable. The contractor should however train local people with the main aim to reduce the required expatriate labour contingent.

Contract mining also reduces capital requirement, since the contractor's operating cost/rate is inclusive of the capital cost of the contract, thus owners are paying for the use of the contractor's capital equipment in a 'pay as you go' manner. An added advantage is that as contracting companies purchase equipment on a regular basis, they are usually able to secure better commercial terms for equipment. Contractors should also be able to deliver greater efficiencies with effective work performance, thereby providing greater value for the owner.

Due to the Project's high capital requirement and the relatively remote location of the mine, it was decided that contractor mining would likely be able to deliver greater efficiencies and work performance to the Project. An ownership charge was included in the operating cost of the equipment and a contractor margin of 10% was used as explained in more detail below. The 10% was applied to the following items:

- Contractors labour.
- Maintenance.
- Ground engaging tools (GETs).
- Tyres.
- Lubricants (hydraulic oil and engine oil).
- Repairs services.
- Ownership cost.

The owner at the original cost and all explosives costs are sourced from a separate contractor still supplies fuel and power.

### 21.8.3.3 Ownership Cost

These costs are calculated for depreciation, interest, insurance, and taxes. The delivered price less the estimated residual value results in the value to be recovered through work, divided by the total usage hours, giving the hourly cost to project the asset's value. However, replacement cost escalation is also considered. Depreciation is calculated by the straight-line method, and includes purchase price, sales tax, freight, and erection cost, with an assumed salvage value of 30%.



Average economic life in hours and average annual operating hours are shown for each size range. Replacement cost escalation is designed to augment the capital recovery, and to offset inflation and machine price increase. Interest on the investment was assumed to be 2.95% based on the Canadian bank lending rate, whereas insurance and property taxes were taken as 1% respectively.

**Table 21-18: Ownership Cost Assumptions**

Item	UoM	Percentage
Canadian Bank Lending Rate	%	2.95
Insurance Rate	%	1.00
Property Tax	%	1.00
Residual value	%	30.00

### 21.8.3.4 Contractor Margin

Contractors provide budget quote estimates when bidding for a specific mining operation and includes a contractor margin on their calculated costs. The contractor’s margin is intended to compensate for both cash and non-cash costs and risk assumption. The following items are reflected in the contractor’s margin:

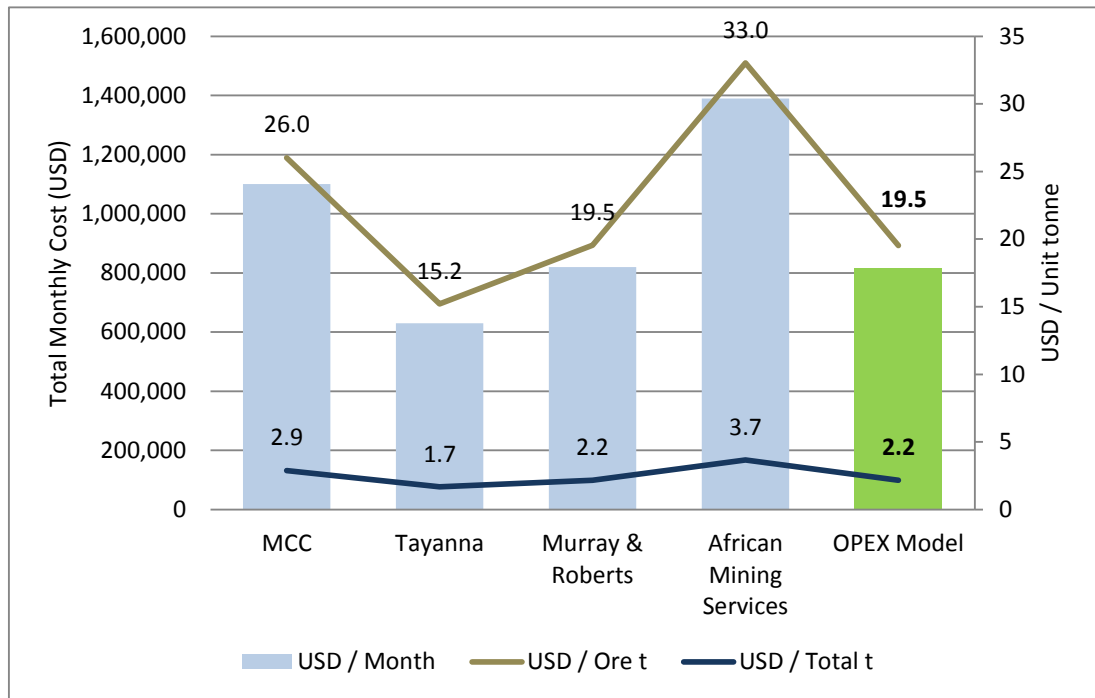
- A return on capital invested.
- Compensation for off-site overhead and other costs.
- A premium for risk assumption.

A typical contractor margin in the mining industry is 20% although there always exists certain opportunities to an actual Opex model built in a PFS.

To test and justify a margin lower than 20%, Advisian benchmarked actual budget quotations (BQ) that were received from four mining contractors in a previous feasibility study completed during 2017. During this study, a similar Opex model was developed based on first principles, which included an ownership charge and a contractor margin of 20%.

The actual BQs received from the contractors were analysed and compared to the operating cost estimation. Each individual contractor BQ includes risks, assumptions and a contractor margin, which were not disclosed, and influences the total BQ estimations.

Three of the actual contractor rates compared well to the Opex model including the 20% margin. MCC, Tayanna and M&R quotations ranges between -22% and +33% of actual Opex model. The BQs rates displayed in the figure below is the initial quotes received before opportunity for negotiation was considered.



**Figure 21-4: Actual Contractor Rates Comparison**

The lowest contractor rate as received from Tayanna was a local mining contractor and hence the lower cost by excluding costs like expats, shipping costs, duties, taxes etc. Based on the information provided, an assumption can be justified that the calculated rate could be reduced to 10% in the PFS by assuming:

- A local contractor might be cheaper.
- During the tendering process, negotiation could reduce the cost.

## 21.8.4 Mining Cost by Element

### 21.8.4.1 Drilling

The drilling operation’s cost breakdown of the different cost per total tonne including ore and waste tonnes is described in Table 21-19. The rate over the LoM amounts to USD0.100/total tonne mined. The cost includes the normal drilling as well as the pre-splitting holes to be drilled. Pre-splitting is a method of blasting in which a planar crack is propagated by blasting to determine the final shape of a rock face before holes are drilled for the final blast pattern; firing with a minimum time scatter can then be used.

**Table 21-19: Drilling Cost Calculation**

Cost Item	Unit	Cost
Labour	USD/total tonne	0.006
Fuel	USD/total tonne	0.032
Drill Tools	USD/total tonne	0.030
Contractor Margin	USD/total tonne	0.007
Ground Engaging Tools (GETs)	USD/total tonne	0.000



Cost Item	Unit	Cost
Repair Services	USD/total tonne	0.001
Maintenance Services	USD/total tonne	0.021
Ownership Cost	USD/total tonne	0.002
<b>Drilling Total</b>	<b>USD/total tonne</b>	<b>0.100</b>

### 21.8.4.2 Blasting

The blasting cost breakdown of the different cost per total tonne including ore and waste tonnes is described in Table 21-20. The rate over the LoM amounts to USD0.287/total tonne mined. Specifications of the blasting pattern and explosives used are detailed in the relevant blasting document of the PFS. The blasting was assumed to be contracted out to independent contractors.

**Table 21-20: Blasting Cost Calculation**

Cost Item	Unit	Cost
Detonating Cord	USD/total tonne	0.004
Boosters	USD/total tonne	0.005
Detonators	USD/total tonne	0.009
Explosives	USD/total tonne	0.111
Presplit Cartridges	USD/total tonne	0.066
Explosive Contractors	USD/total tonne	0.009
Transportation costs for explosives	USD/total tonne	0.003
Transportation costs for explosive accessories	USD/total tonne	0.001
Lead in line	USD/total tonne	0.003
Miscellaneous	USD/total tonne	0.074
<b>Blasting Total</b>	<b>USD/total tonne</b>	<b>0.287</b>

### 21.8.4.3 Loading

The shovel is used to load ore and waste for the Yandera open pit operation into the haul trucks. The breakdown of the different cost items per total tonne is described in Table 21-21. The rate over the LoM amounts to USD0.287/total tonne mined.

**Table 21-21: Excavator Cost Calculation**

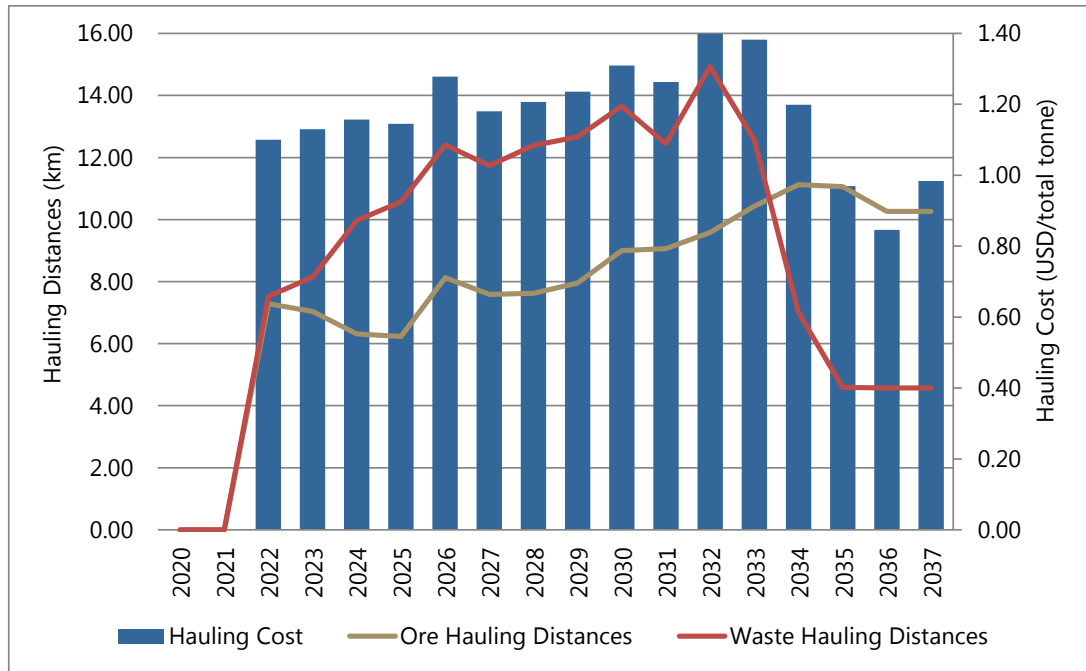
Cost Item	Unit	Cost
Labour	USD/total tonne	0.061
Maintenance Services Cost	USD/total tonne	0.074
Fuel	USD/total tonne	0.100
Lubes	USD/total tonne	0.002
Repair Services Cost	USD/total tonne	0.004
Equipment Owning Costs	USD/total tonne	0.030
Contractor Margin	USD/total tonne	0.017
<b>Loading Total</b>	<b>USD/total tonne</b>	<b>0.287</b>





### 21.8.4.4 Hauling

The cost of hauling increases with distance and depth. As the hauling distance increases, the amount of trucks also increases. The ore tonnes are transported to the crusher and conveyor situated close to the mining precinct while the waste is transported to the waste rock dump. The effect of the increase in distance on the hauling cost is displayed graphically in Figure 21-5.



**Figure 21-5: Hauling Distances and Hauling Cost**

It can be seen that the ore hauling distance gradually increase as the mining becomes deeper and the distances to the precinct further away. The waste hauling distances increases steeply because of the distance to the tipping of the waste on the waste rock dump becoming further and further away.

In 2036 there is a dip in the waste hauling distances when Gremi is mined out, which gives the potential for the other pits to dump waste directly in the mined out pit, thus decreasing hauling distances significantly. The hauling distances and travelling times of the trucks were also tested by haul infinity software. Haul Infinity is the most advanced mining haulage analysis software available, which combines cycle time simulation, 3D design, and fast reporting. Based on the outputs of haul infinity, the cycle times and distances are regarded as more than accurate for a PFS level of accuracy.

The hauling operation’s breakdown of the different cost per total tonne including ore and waste tonnes is described in Table 21-22. The rate over the LoM amounts to USD1.169/total tonne mined. These costs include the saving due to the use of trolley assist that was proposed to be used on the trucks.



**Table 21-22: Truck Hauling Cost Calculation**

Cost Item	Unit	Cost
Maintenance Services	USD/total tonne	0.215
Fuel	USD/total tonne	0.610
Lubes	USD/total tonne	0.014
Tires	USD/total tonne	0.203
Repair Services	USD/total tonne	0.011
Ownership Cost	USD/total tonne	0.066
Contractor Margin	USD/total tonne	0.051
<b>Hauling Total</b>	<b>USD/total tonne</b>	<b>1.169</b>

#### 21.8.4.5 Auxiliary Services

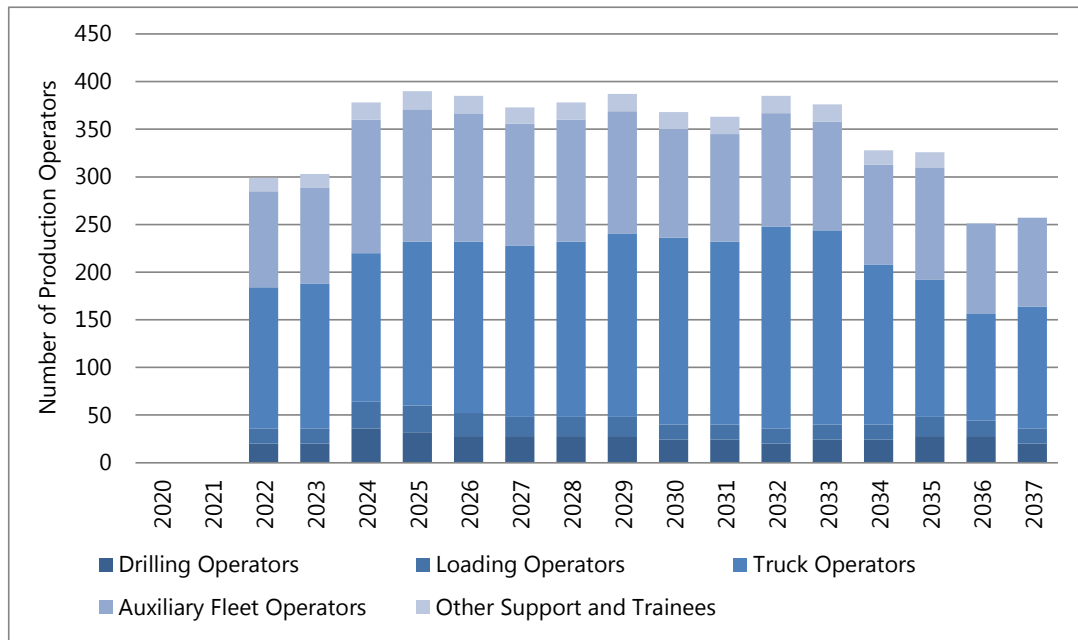
Services comprise the equipment used to assist the mining fleet. This equipment is the bulldozers, wheel dozers, diesel bowzers, water trucks, graders, lowbed trucks, backhoes, front-end-loaders (FEL) and light delivery vehicles (LDVs). This equipment forms part of the sub-activity services and the breakdown of the cost per total tonne is shown in Table 21-23 below.

**Table 21-23: Auxiliary Services Cost Calculation**

Cost Item	Unit	Cost
Labour	USD/total tonne	0.027
Fuel	USD/total tonne	0.123
Tires	USD/total tonne	0.034
Contractor Margin	USD/total tonne	0.044
GETs	USD/total tonne	0.014
Repair Services	USD/total tonne	0.002
Maintenance Services	USD/total tonne	0.263
Ownership Cost	USD/total tonne	0.010
Miscellaneous	USD/total tonne	0.017
<b>Auxiliary Total</b>	<b>USD/total tonne</b>	<b>0.534</b>

#### 21.8.4.6 Production Labour Complement

The labour complement contributing to the variable cost per sub-activity is shown in Figure 21-6. The labour complement is based on four crews per machine working on a 4x4-shift regime. The cost of this labour complement is included in the breakdown per mining activity discussed above.



**Figure 21-6: Production Labour Complement**

### 21.8.4.7 Dewatering

The dewatering cost has two main components namely the power cost associated with operating the pumps as well as the cost to service the pumps every 2,500 hours of operation. The total cost is relatively small compared to the total mining cost and amounts to USD0.021/total tonne.

**Table 21-24: Dewatering Cost Calculation**

Cost Item	Unit	Cost
Power	USD/total tonne	0.009
Maintenance	USD/total tonne	0.012
<b>Dewatering Total</b>	<b>USD/total tonne</b>	<b>0.021</b>

### 21.8.4.8 Fixed Costs

The total workforce for the open pit operation excluding the production labour amounts to approximately 53 people. The labour requirements were determined by engineering judgment based on similar projects. The labour cost amounts to USD2.68million per annum.



Table 21-25 shows the breakdown of the total fixed costs over the LoM. The minor supplies include the software licenses and safety wear. Other mobile equipment includes the cranes, lightning towers, service trucks and other engineering equipment. The total fixed costs amount to approximately USD0.062/total tonne over the LoM.



**Table 21-25: Fixed Costs Breakdown over LoM**

Cost Item	Unit	Cost
Fixed Labour	USD/total tonne	0.038
Minor Supplies	USD/total tonne	0.011
Mobile Equipment	USD/total tonne	0.007
Roads Maintenance	USD/total tonne	0.004
Other External Services	USD/total tonne	0.002
<b>Fixed Cost Total</b>	<b>USD/total tonne</b>	<b>0.062</b>

### 21.8.5 Mining Operating Cost Summary

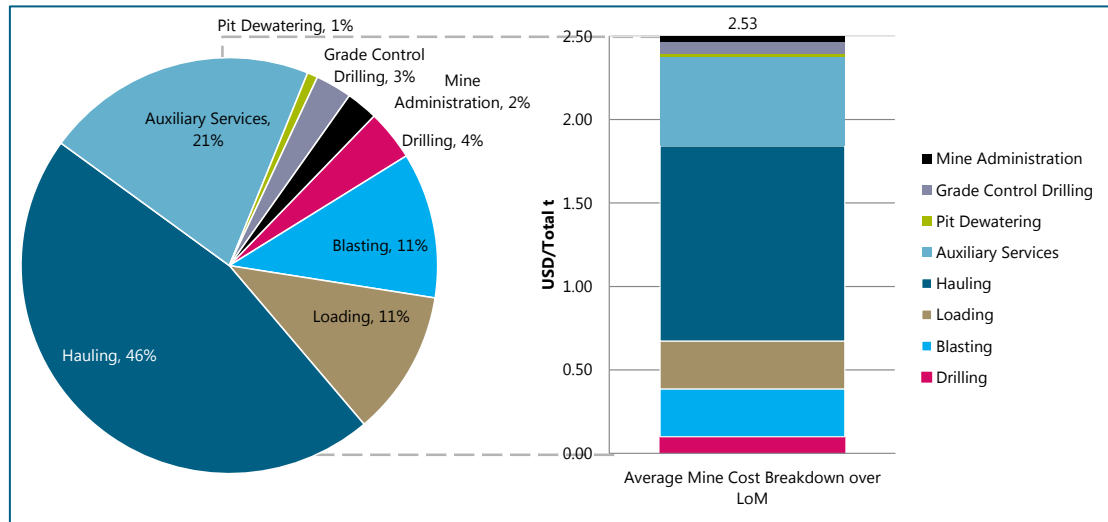
The operating cost breakdown in Table 21-26 indicates the average main cost activities per total tonne mined over the LoM for the contractor operated mine. These main activities were broken down into distinct activities each with its own unit of measure as described in detail in Section 1.1.1.6. The average total cost amount to USD2.53/total tonne mined (ore and waste) over the LoM, which relates to USD5.87/milled tonne.

**Table 21-26: Mining Operating Cost Breakdown**

Cost Item	Cost (USD/ total tonne)	Cost (USD/milled tonne)
Drilling	0.10	0.23
Blasting	0.29	0.67
Loading	0.29	0.66
Hauling	1.17	2.71
Auxiliary Services	0.53	1.24
Pit Dewatering	0.02	0.05
Grade Control Drilling	0.07	0.17
Fixed Costs	0.06	0.14
<b>Total</b>	<b>2.53</b>	<b>5.87</b>



The contribution to the operating cost by each cost element over the LoM is illustrated in Figure 21-7.



**Figure 21-7: Mining Cost Contribution by Element**

The hauling contributes the most to the operating cost at 46% followed by the auxiliary services at 21%.

## 21.8.6 Accuracy of Mining Cost Estimation

### 21.8.6.1 Introduction

The level of confidence for the actual un-escalated operating cost estimate in terms of US dollars per tonne for the Project has been determined by applying a confidence level from Table 21-27 to each unit cost and rate applied in the operating cost model.

**Table 21-27: Level of Confidence**

Level of Confidence Scale		
1	First Principals using Actual Cost	5%
2	Suppliers/Manufacturer Rate	10%
3	Benchmarked from Previous Project (Related Size)	20%
4	Benchmarked from Previous Project (Scaled Size)	25%
5	Estimation	30%

### 21.8.6.2 Level of Accuracy

According to the mining reporting codes, a PFS should have an accuracy range between 15% - 25%. The weighted average level of confidence was determined per as activity and sub-activity by assigning the scale described in Table 21-28.





This scale is applied per activity and sub-activity whereby a weighted average was calculated as per Table 21-28.

**Table 21-28: Level of Accuracy**

Activity	Accuracy	Cost Weighting	Weighted Accuracy
Drilling	21.7%	3.9%	0.9%
Blasting	25.0%	11.3%	2.8%
Loading	21.2%	11.3%	2.4%
Hauling	19.0%	46.2%	8.8%
Auxiliary Services	19.8%	21.1%	4.2%
Pit Dewatering	25.0%	0.8%	0.2%
Grade Control Drilling	25.0%	2.8%	0.7%
Fixed Costs	13.2%	2.4%	0.3%
<b>Grand Total</b>		<b>100.0%</b>	<b>20.3%</b>

From Table 21-28 it can be seen that the level of accuracy overall is 20.3% which is within PFS limits of 15% - 25%.

## 21.8.7 Processing Costs

### 21.8.7.1 Introduction

The treatment operating costs relate to the RoM treated tonnes. Treatment operating costs cater for the milling plant situated at the mining precinct as well as the flotation plant located at the coastal facilities. The molybdenite recovery circuit is reported separately from the copper recovery circuit.

Treatment operating costs were developed using the following inputs:

- Process Design Criteria.
- Electrical load list.
- Equipment operating hours and number of units.
- Labour forecast.
- Capital cost estimate for mechanical equipment.

Where possible, vendor quotations were used to build up the unit rates for consumables supply. In the absence of vendor data, benchmark-operating costs were sourced. Maintenance costs for conveyors, ball mill and other fixed equipment were determined using a percent of the equipment capital cost based on subject matter expert experience and judgement.

The cost of the first fills for reagents and grinding media was included in the capital estimate and does not form part of the Opex.



## 21.8.7.2 Reagents and Consumables

The reagent schedule for both the flotation plant as well as the milling plant have been completed and Advisian have send out the lists to producers in PNG for quotations on the prices. The reagent schedule for the milling plant and flotation plant displayed in the following tables were calculated at steady state steady state production of 30Mtpa of ore.

The reagent and consumable costs per material and chemical are based on vendor quotes received from various suppliers. The quotes were received based on either: cost, insurance and freight (CIF) or cost and freight (CFR) at whichever the port of Lae or Port of Moresby (PoM). Separate quotes were then received for the transport of the reagents and consumables to the relevant quotations and displayed separately in the tables to follow. This was used in the final calculation of the reagents and consumables per tonne milled. All costs displayed in the tables below are based on a steady state ore production rate of 30Mtpa.

The costs are split between the milling, flotation plant for oxides and sulphides and the moly circuit (Yandera Process Consumables Cost Schedule, C00651-0000-PR-LST-0003).

### 21.8.7.2.1 Milling Plant Cost

The transport distance of all reagents and consumables is based on the distance of 306km from the port to the precinct at an average elevation of 1,540mamsl. The total cost of the milling plant consumables and reagents were calculated to be USD1.01/t milled during steady state. The breakdown of the cost is displayed in Table 21-29.

**Table 21-29: Milling Plant Reagents and Consumables Cost**

Name	Consumption Rate (tpa)	Wharfage Cost (USD/t)	Transport Cost (USD/annum)	Supply Cost (USD/t)	Supply Cost Basis	Total Cost (USD/t milled)
Flocculant (milled slurry)	450	11.20	34,920	3,000	CFR PoM	0.05
Coagulant	300	11.20	23,280	3,000	CFR PoM	0.03
Grinding Balls (125-150mm)	9,600	11.20	744,960	955	CIF Lae	0.33
Grinding Balls (65-80mm)	12,000	11.20	931,200	865	CIF Lae	0.38
Mill Liners	1,500	11.20	116,400		CIF Lae	0.22
<b>Total Cost</b>						<b>1.01</b>

It is assumed that these goods are imported duty free, in accordance with the latest published PNG Customs tariffs, and that a charge of USD11.20/t wharfage cost will be incurred. Costs for shipping delivery to Madang are assumed to be similar to PoM.



### 21.8.7.2.2 Flotation Plant Cost

The flotation cost per tonne is split between the flotation cost of the sulphides and the oxides. The transport cost was calculated based on a barging cost of 54km to site. The supply cost basis is CFR PoM for all reagents and consumables. The cost to treat the sulphides was calculated to be USD0.33/sulphide tonne milled as described in Table 21-30.

**Table 21-30: Sulphide Flotation Plant Reagents and Consumables Cost**

Name	Consumption Rate (tpa)	Transport Cost (USD/annum)	Supply Cost (USD/t)	Total Cost (USD/t milled)
Collector PAX	1,500	198,856	2,133	0.11
Frother – MIBC	1,200	159,085	3,036	0.13
Flocculants (tailings)	450	59,085	3,000	0.05
Flocculants (Cu concentrate)	7.3	966	3,000	0.00
Coagulant	300	39,771	1,920	0.02
Grinding Beads (3-12mm)	578	76,615	899	0.02
<b>Total Cost</b>				<b>0.33</b>

The cost to treat the oxides was calculated to be USD1.85/oxide tonne milled as described in Table 21-30. The increase in the cost compared to the sulphide cost is due to higher consumption rates of PAX and additional reagents that are required (NaHS and an oxide collector (OX-100)).

**Table 21-31: Oxide Flotation Plant Reagents and Consumables Cost**

Name	Consumption Rate (tpa)	Transport Cost (USD/annum)	Supply Cost (USD/t)	Total Cost (USD/t milled)
Collector PAX	6,000	795,424	2,133	0.46
NaHS	19,500	2,585,129	445	0.38
Collector (oxide) – OX-100	3,000	397,712	10,500	1.17
Frother – MIBC	1,200	159,085	3,036	0.13
Flocculant (tailings)	450	59,657	3,000	0.05
Flocculant (Cu concentrate)	6.5	856	3,000	0.001
Coagulant	300	39,771	1,920	0.02
Grinding Beads (3-12mm)	903	119,711	899	0.03
<b>Total Cost</b>				<b>1.85</b>

It is assumed that these goods are imported duty free, in accordance with the latest published PNG Customs tariffs, and that a charge of USD14.58/t wharfage cost will be incurred.



### 21.8.7.2.3 Mo Circuit Plant Cost

The cost of the Mo circuit as an add-on to the flotation plant was calculated to be USD0.0063/t milled as described in Table 21-32. The transport cost was calculated based on a barging distance of 54km to site. The supply cost basis is CFR PoM for all reagents and consumables.

**Table 21-32: Mo Circuit Plant Reagents and Consumables Cost**

Name	Consumption Rate (tpa)	Transport Cost (USD/annum)	Supply Cost (USD/t)	Total Cost (USD/t milled)
NaHS	308	40,805	455	0.0061
Kerosene	6.5	859	719	0.0002
Flocculants (Mo concentrate)	0.11	15	3,000	0.0000
<b>Total Cost</b>				<b>0.0063</b>

### 21.8.7.3 Processing Labour

The manning estimate for the milling and flotation plant is described in detail in the following tables. The grade per position is based on typical rates for the type of position in the industry as per the Patterson grading system. The treatment labour cost is fixed, as no additional positions are required to process the increased feed over the life of the mine.

#### 21.8.7.3.1 Milling Plant Labour

The following assumptions were made about the milling plant situated at Yandera:

- Two shifts per day (12 hours per shift).
- No allowance for G&A staff - this is process plant labour only.
- No allowance for Assay laboratory staff - assumed to be contracted out to an independent operator.
- Specialist services e.g. analyser maintenance and mill relining also contracted out.
- Includes crusher area.
- Includes all operations and maintenance staff for process plant function.
- Excludes slurry pipeline operation and maintenance - provided by BRASS Engineering.
- Maintenance planning function catered for under flotation plant.
- Process and Engineering Management catered for under flotation.
- Training Roles catered for under flotation.
- Senior Plant Metallurgist catered for under flotation.

The total number of employees for the milling plant was calculated to be 72 of which the majority (85%) would be locals. The positions of the plant metallurgist and production superintendent in training are assumed to replace the expats after 3 years of production.



### 21.8.7.3.2 Flotation Plant Labour

The following assumptions were made concerning the flotation plant and Mo circuit situated at Cape Rigny:

- Two shifts per day (12 hours per shift).
- No allowance for G&A staff - this is process plant labour only.
- Cape Rigny camp maintenance catered for, camp management contracted out.

The total number of employees for the flotation plant was calculated to be 143 of which the majority (87%) would be locals.

The total cost per annum for the labour of the milling plant amounts to USD3.13million per annum, which equals USD0.10 per milled tonne at steady state. The total cost per annum for the labour of the flotation plant amounts to USD5.56million per annum, which equals USD0.19 per tonne, milled at steady state. A breakdown summary of the processing labour cost per division is displayed in Table 21-33.

**Table 21-33: Plant Labour Cost Summary**

Division	Unit	Amount
Management	USDm	1.84
Operations	USDm	1.16
Technical Services	USDm	0.83
Maintenance	USDm	4.85
<b>Total Plant Labour Cost</b>	<b>USDm</b>	<b>8.69</b>

### 21.8.7.4 Maintenance Costs

The maintenance costs of the processing plants displayed below were based on a percentage of the capital expenditure and are described in Table 21-34.

**Table 21-34: Plant Maintenance Cost per Annum**

Item	% of Capital	Unit	Amount
Milling Plant	3.0%	USDm	3.78
Flotation Plant	2.5%	USDm	1.52
Mo Circuit	3.0%	USDm	0.11

Maintenance costs for the first year of operation are excluded from the operating cost estimate as provision is made in the capital cost estimate for critical, commissioning and 12months operational spares.

### 21.8.7.5 Power Costs

The power cost of the plants is based on the power consumption of each of the circuits at a rate of USD0.13/Kwh. The power cost per tonne milled during steady state is described in Table 21-35.



**Table 21-35: Plant Power Cost Tonne Milled**

Item	Unit	Amount
Milling Plant	USD/tonne milled	2.98
Flotation Plant	USD/tonne milled	0.33
Mo Circuit	USD/tonne milled	0.01

### 21.8.7.5.1 Miscellaneous Costs

Miscellaneous costs contribute 4% to the overall processing costs. Items covered in this category include:

- Filter cloths (based quoted costs from a similar project).
- Assay fees based on contract management of laboratory (benchmarked against quoted rates for a similar project, and adjusted for increased sample quantity).
- Note that assay costs include for mine grade control at 116 samples per day, metallurgical samples for metal accounting and process control at 54 per day, and environmental monitoring and water quality at 40 samples per day.
- Contractors for maintenance of plant analysers and mill relining (based quoted costs from a similar project).
- Plant mobile fleet maintenance and fuel costs (based on the Yandera plant mobile fleet selected and calculated running costs from a similar project).
- An allowance is also included for miscellaneous consumables.

Miscellaneous costs are allocated equally between the milling and flotation plants.

**Table 21-36: Miscellaneous Cost per Annum**

Item	Unit	Amount
Milling Plant	USD/tonne milled	3.41
Flotation Plant	USD/tonne milled	3.41

### 21.8.7.5.2 Processing Cost Summary

The summary of the milling, flotation and Mo circuit is described in Table 21-37. The total cost amounts to USD5.49 per tonne milled.

**Table 21-37: Processing Cost Summary**

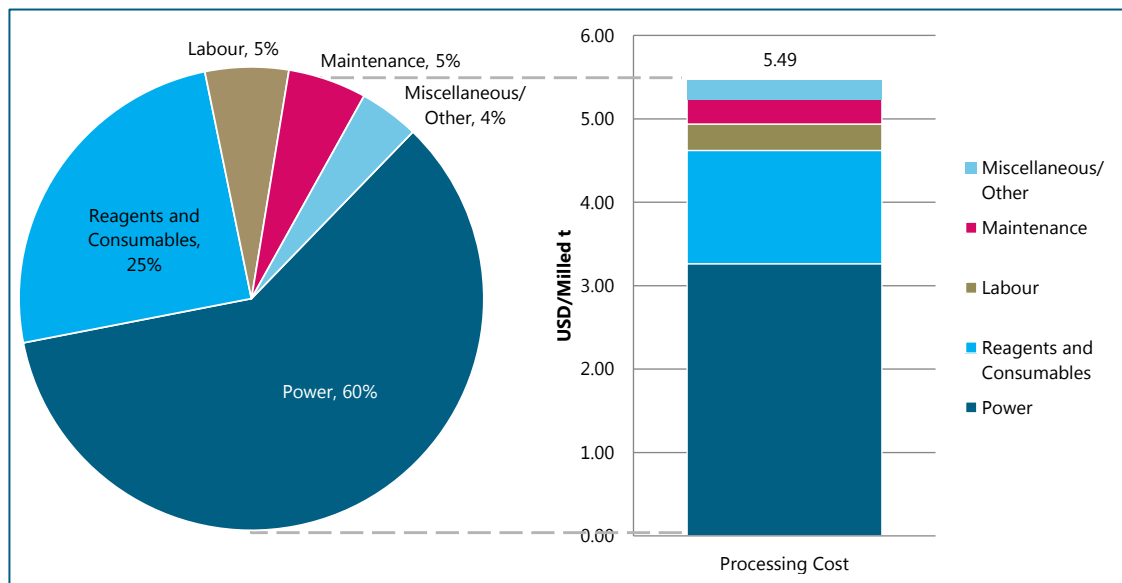
Processing Activity	Item	Amount
Milling Plant and Mine Support Infrastructure	Power	2.98
	Labour	0.10
	Maintenance	0.22
	Reagents and Consumables	1.01
	Miscellaneous/ Other	0.11
<b>Milling Plant Sub-Total</b>		<b>4.42</b>





Processing Activity	Item	Amount
Flotation Plant	Power	0.33
	Labour	0.19
	Maintenance	0.08
	Reagents and Consumables	0.34
	Miscellaneous/ Other	0.11
<b>Flotation Plant Sub-Total</b>		<b>1.04</b>
Mo Circuit	Power	0.01
	Maintenance	0.00
	Reagents and Consumables	0.01
<b>Mo Circuit Sub-Total</b>		<b>0.03</b>
<b>Total Processing Cost</b>		<b>5.49</b>

The majority of the cost (60%) is power cost followed by reagents and consumables contributing to 25% of the total processing cost. A breakdown of the total processing cost is displayed graphically in Figure 21-8.



**Figure 21-8: Processing Cost Breakdown**



## 21.8.8 Accuracy of Processing Cost Estimation

### 21.8.8.1 Introduction

The level of confidence for the actual un-escalated operating cost estimate in terms of US dollars per tonne for the Project has been determined by applying a confidence level as described.

### 21.8.8.2 Level of Accuracy

According to the mining reporting codes, a PFS should have an accuracy range between 15% - 25%. The weighted average level of confidence was determined per as activity and sub-activity by assigning the scale described in Table 21-38. This scale is applied per activity and sub-activity whereby a weighted average was calculated as per table below.

**Table 21-38: Level of Accuracy**

Activity	Accuracy	Cost Weighting	Weighted Accuracy
Labour	20.0%	5.3%	1.1%
Maintenance	25.0%	5.4%	1.4%
Reagents and Consumables	15.0%	24.7%	3.7%
Miscellaneous	30.0%	4.1%	1.2%
Power	15.0%	60.4%	9.1%
<b>Grand Total</b>		<b>100.0%</b>	<b>16.4%</b>

From Table 21-38 it can be seen that the level of accuracy overall is 16.4% which is well within PFS limits of 15% - 25%.

## 21.8.9 Other Costs

### 21.8.9.1 General and Administration

The General and Administration (G&A) operating costs relate to support services for security, human resources, travelling costs, occupational health and safety, commercial, supply and logistics, information technology and communications, environmental and community affairs. The G&A costs were based on a similar mine feasibility study in PNG and deemed as sufficient for the PFS.

### 21.8.9.2 Assumptions

The following assumptions were made as per general and administration cost item:

- Community affairs cost is based on fixed costs per year that have been extrapolated from community affairs capital estimate.
- Commercial cost consists of legal, auditing, taxation bank fees and insurance. Costs are based on scaled Hidden Valley current costs (except insurance). Property damage insurance included in the model is based on an annual cost of USD3.4million per year along with additional in country insurance.



- The Fly-In-Fly-Out (FIFO) and Drive-In-Drive-Out (DIDO) travel costs are calculated using the total headcount and the applicable travel rates as supplied by the WGJV for DIDO and current Morobe Mining Joint Ventures (MMJV) pricing for FIFO based on the current MMJV Group pricing agreement.
- Human resources cost is calculated using the total headcount and unit rates from current Hidden Valley operations.
- Information technology costs are based on a zero-base capital and operating cost estimate.
- Occupational health and safety is based on current Hidden Valley operations adjusted for the Yandera PFS.
- The security for the mines, plant and port was assumed to be contracted out to the Asset Protection Department (APD) in PNG. The APD is contracted out to similar mining operations in PNG and their functions are:
  - Physical security from mine to port.
  - Reserve Royal Papua New Guinea Police Constabulary duties.
  - Community policing.
  - Internal investigations.
  - Community, government, police and industrial liaison.
  - Fire suppression, safety, detection, prevention and maintenance.
  - Land, sea, and air rescue.
  - Crisis/disaster management and response.
- Yandera will have social responsibility programmes that include recruiting from local areas wherever possible, engaging local business for contract services and developing partnerships with the local communities, governments and business in order to improve long-term social and economic development.

### 21.8.9.3 General and Administration Labour

Labour costs for G&A accounts for the staff required to provide support services to the total mining and treatment operations. The activities included in the labour estimate are displayed in Table 21-39 and amounts to a total labour complement of 299 over the LoM. The total cost amounts to USD7.2million per annum.

**Table 21-39: General and Administration Labour Breakdown**

Activity	UoM	Rates UoM	Cost Type	LoM Average
Security	no	USD/month	Fixed	102
Financial and Commercial	no	USD/month	Fixed	19
Community Affairs	no	USD/month	Fixed	17
Environment	no	USD/month	Fixed	12
Human Resources	no	USD/month	Fixed	27
IT and Communication	no	USD/month	Fixed	8
Management	no	USD/month	Fixed	3



Activity	UoM	Rates UoM	Cost Type	LoM Average
Occupational Health and Safety	no	USD/month	Fixed	58
Supply & Logistics	no	USD/month	Fixed	53
<b>Total Labour Complement</b>				<b>299</b>

#### 21.8.9.4 General and Administration Cost Summary

The total cost for the general and administration was calculated to be USD23.34million per annum, which amounts to USD0.91/t milled during steady state.

**Table 21-40: General and Administration Cost per Annum**

Item	Unit	Amount
Labour	USDm/annum	6.58
Financial and Commercial	USDm/annum	5.67
Community Affairs	USDm/annum	0.59
Environment	USDm/annum	0.71
Human Resources	USDm/annum	3.00
IT and Communication	USDm/annum	5.50
Occupational Health and Safety	USDm/annum	0.46
Supply & Logistics	USDm/annum	0.82
<b>Total Cost per Annum</b>	<b>USDm/annum</b>	<b>23.34</b>

#### 21.8.9.5 Accommodation Camp Costs

Accommodation camp costs have been calculated based on current contract rates, rosters and headcount. The total accommodation camp costs amounts to USD6.8million per year, of which USD4.6million is attributable to the campsite at the Yandera precinct and USD2.3million attributable to the camp at the coastal facilities.

#### 21.8.9.6 Road Maintenance

The road maintenance costs were benchmarked from in-house data of a project situated in PNG. The cost amounts to USD488/km of roads per annum and was applied to all the applicable roads of the Project.

#### 21.8.10 Opex for Ore Slurry Pipeline System

The calculated annual operating cost is USD8.91million. The transportation cost is USD0.30/t at annual throughput of 30Mt. The cost breakdown is shown in Table 21-41 below.



**Table 21-41: Ore Slurry Pipeline Operating Cost**

Item	Description	Amount (USDm per annum)
<b>Total Operating Cost</b>		<b>8.91</b>
1	Power Cost	0.27
2	Water Cost	2.51
3	Manpower, Vehicles and Plant Cost	0.73
4	Pipeline and Right-of-Way Maintenance Cost	5.41

### 21.8.11 Opex for DSTP System

The annual operating cost for the DSTP system is USD1.93million. The breakdown of the cost is listed in Table 21-42 below.

**Table 21-42: DSTP Operating Cost**

Item	Description	Amount (USDm per annum)
<b>Total Operating Cost</b>		<b>1.93</b>
1	Power Cost	0.001
2	Manpower, Vehicles and Plant Cost	0.08
3	Environmental Monitoring Cost	0.25
4	Outfall Replacement Cost	1.60

#### 21.8.11.1 Other Maintenance

The maintenance cost of various other items displayed below was based on a percentage of the capital expenditure and is described in Table 21-43

**Table 21-43: Other Maintenance Cost per Annum**

Item	% of Capital	Unit	Amount
Yandera Precinct Support Services	2%	USDm	0.18
Yandera Precinct Infrastructure	2%	USDm	1.67
Power Supply Intake Sub-Station	2%	USDm	0.52
Banu Diesel Storage and Infrastructure	2%	USDm	0.01
Coastal Facilities Infrastructure	2%	USDm	0.40
Coastal Facilities Support Services	2%	USDm	0.48

The majority of the other costs described in this section were either benchmarked from previous projects or estimated with an accuracy range of between 20% – 30%.



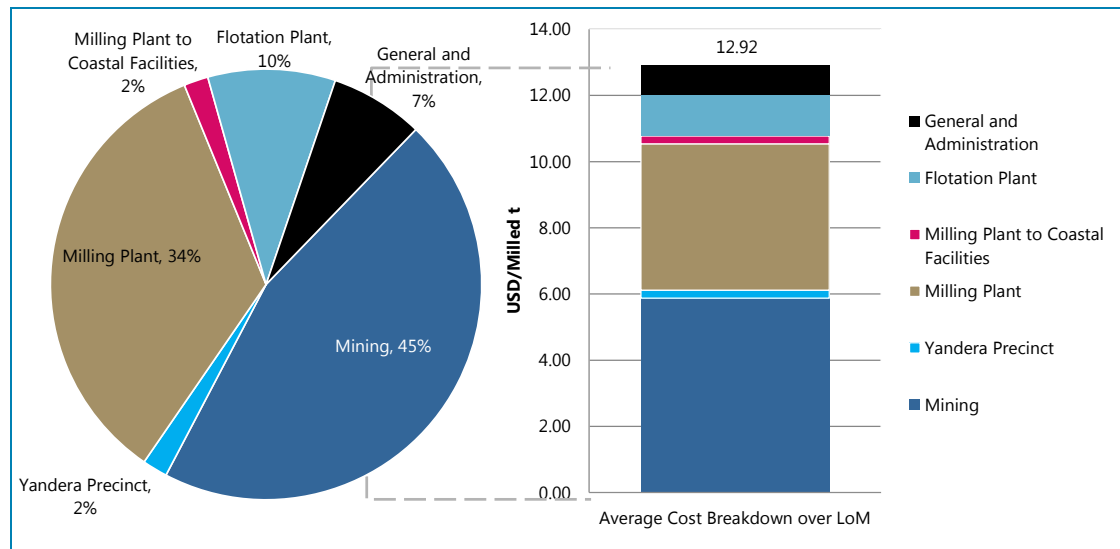
### 21.8.11.2 Opex Summary

The average total cost amounts to USD12.92/milled total tonne milled over the LoM as described in Table 21-44.

**Table 21-44: Operating Cost Breakdown**

Cost Item	Unit	Cost
Mining	USD/milled tonne	5.87
Yandera Precinct	USD/milled tonne	0.24
Milling Plant	USD/milled tonne	4.42
Mill to Coastal Facilities	USD/milled tonne	0.24
Coastal Facilities	USD/milled tonne	1.24
General and Administration	USD/milled tonne	0.91
<b>Total Opex</b>	<b>USD/milled tonne</b>	<b>12.92</b>

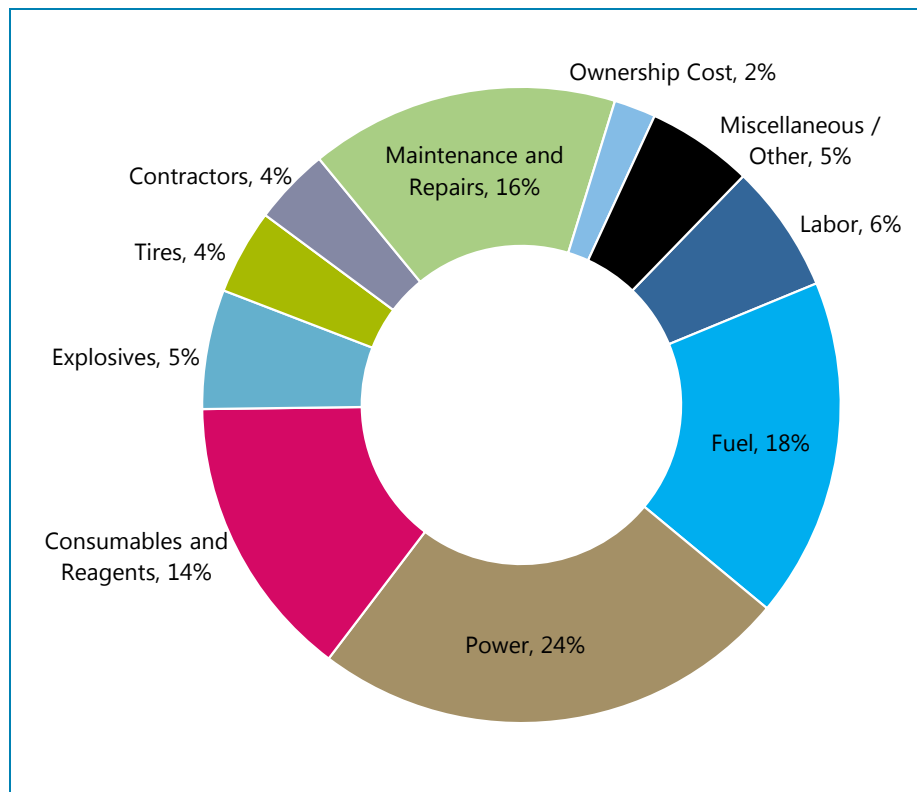
The contribution to the operating cost by each cost element over the LoM is illustrated in Figure 21-9



**Figure 21-9: Total Cost Contribution by Element**

The mining contributes the most to the operating cost at 45% followed by the milling and flotation plant contributing another 44%. A breakdown of the cost by sub-activity is described in Figure 21-10. The major contributors to the cost are power and fuel.





**Figure 21-10: Cost Breakdown per Sub-activity**

The operating expenditure (Opex) DNA was structured according to the following breakdown as indicated in Figure 21-11

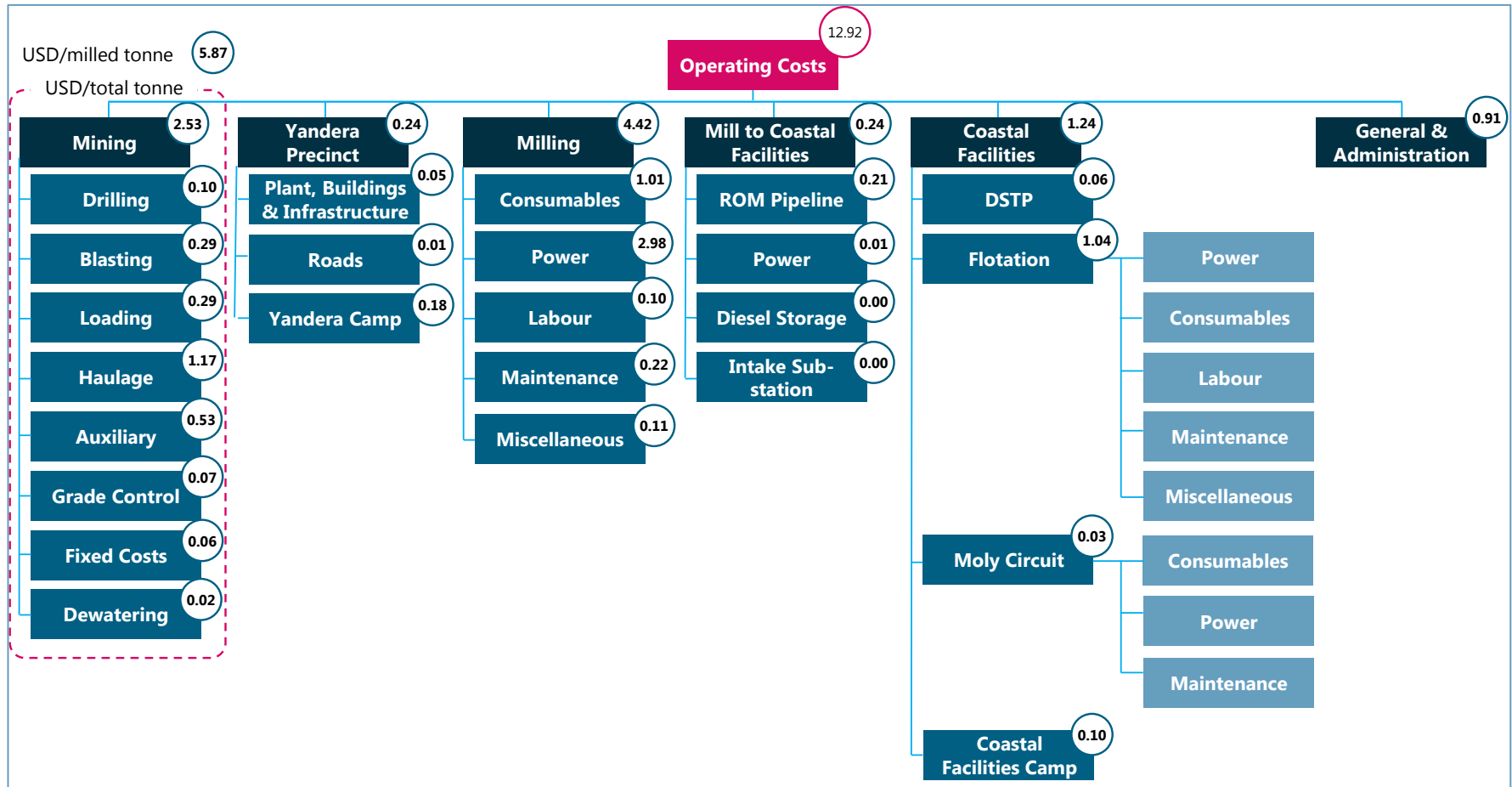


Figure 21-11: Opex DNA Summary



## 22 Economic Analysis

---

The economic analysis describes the assumptions and methodology that was applied to evaluate the feasibility of the Yandera project. This section should not be read in isolation, as there are various technical and non-financial considerations that the reader should consider.

### 22.1 Key Project Variables

The key project variables for the business case consist of macro-economic assumptions, production statistics and cost related inputs. Macro-economic inputs refer to commodity price forecasts, realization charges or selling expenses, and escalation and de-escalation rates. Production related inputs comprise of production profiles for Gremi, Omora, Imbruminda, Dimbi, Gamagu, South 1 and South 2 pits. These profiles include the following information for copper, gold and molybdenum, for each pit that will be mined:

- Grade (above and below cut-off material).
- Waste tonnes.
- Ore tonnes.
- Oxides, sulphides and transition material.

Cost related inputs are categorized into:

- Project- and sustaining capital;
- Mining, Yandera precinct, milling. plant to coastal facilities, coastal facilities, general and administration, and mine rehabilitation costs; and
- Income tax.

The key project variables form the base of the financial model and are used to determine the Project's free cash flow and valuation metrics, such as NPV, IRR, payback period and other relevant metrics. Figure 22-1 lists the key variables and other drivers, which influence the project returns.

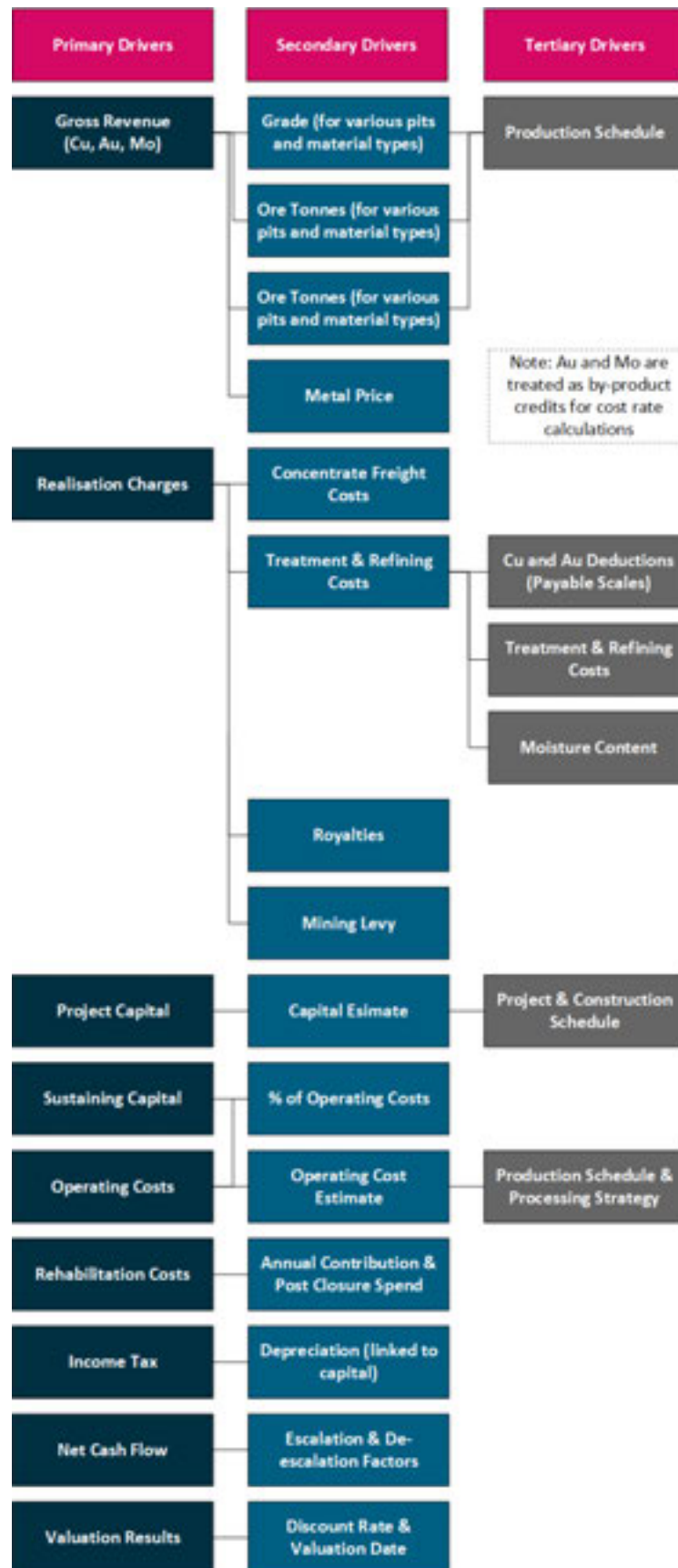


Figure 22-1: Key Project Variables



## 22.2 Assumptions and Investment Evaluation Practices

The following valuation approaches are three internationally accepted methods of valuing projects (see Table 22-1). Valuation methods are, in general, subsets of valuation approaches:-

- **Cost Approach:** includes the Appraised Value method which is widely used and the Multiple of Exploration Expenditure which is used to value early-stage exploration properties. The valuation is dependent on the historical and future exploration expenditure, as this approach is based on the principle of contribution to value.
- **Market Approach:** used to value exploration and development properties, based on the relative comparisons of similar properties for which a transaction is available, in the public domain. The comparable transaction method approach, which is the most widely used, relies on the principle of “willing buyer, willing seller” and requires that the amount obtainable from the sale of the Copper asset is determined as if in an arm’s-length transaction.
- **Income Approach:** the discounted cash flow (“DCF”), Monte Carlo Analysis and Option Pricing are amongst the methods included under this category. The DCF is widely used and generally used to value development and production properties in the production phase. This method relies on the “value-in-use” principle and requires determination of the present value of future cash flows over the useful life of the mineral asset.

**Table 22-1: Acceptable Methods of Mineral Project Valuation**

Valuation Approach	Exploration Properties	Development Properties	Production Properties	Dormant Properties	
				Economically Viable	Not Viable
Income	Not generally used	Widely used	Widely used	Widely used	Not generally used
Market	Widely used	Less widely used	Quite widely used	Quite widely used	Widely used
Cost	Widely used	Not generally used	Not generally used	Not generally used	Less widely used

The DCF valuation is based on future free cash flow discounted to present value. This analysis is widely used within investment banking and company valuation. The DCF is based on the Production Schedule and all costs associated to develop, mine and process the Reserve. Relevant taxation and other operating factors, such as recoveries and stay-in-business costs are incorporated into the valuation to produce a cash flow over the life cycle of the project.

The DCF method was applied to evaluate the Yandera project as it is widely accepted to be the preferred method for development properties at PFS level.



A detailed financial model was developed to analyse the economic viability of the Project. The model forecasts both real and nominal, pre- and post-tax, free cash flows, which were discounted to determine the project returns. The business case financial model assumptions are listed in Table 22-2 and Table 22-3.

**Table 22-2: Valuation Assumptions**

Description	Assumption
Method of analysis	Discounted cash flow
Cash flows	Real and Nominal
Evaluation start date	01 January 2019
Internal Rate of Return (IRR)	Based on undiscounted free cash flow (post tax)
Net Present Value (NPV)	Based on undiscounted cash flow (post-tax)
Payback period	Based on cumulative undiscounted free cash flow (post tax)
Discount rates	10% Nominal 7.8% Real
Revenue escalations	Compounded at US CPI over the LoM; January 2017 base date.
Capital escalations	Compounded at US CPI over the LoM; January 2018 base date.
Operating cost escalations	Compounded at US CPI over the LoM; June 2017 base date.

Life cycle costing principles were applied to ensure that cash flows for the entire life of mine (LoM) were considered, and a discounted cash flow analysis was performed to determine the project NPV. The discounted cash flows were determined by escalating the base cash flows by the applicable escalation rates, and then de-escalating it by a consumer price index (CPI) factor for the relevant year.

An incremental costing methodology was adopted for the Greenfields project. Incremental, in this context, refers to any additional in- or outflows of cash, which will realise as a direct result of the Project being approved and implemented. Alternatively, stated, incremental cash flows are income and expenses, which will be avoided if the Project does not progress any further.

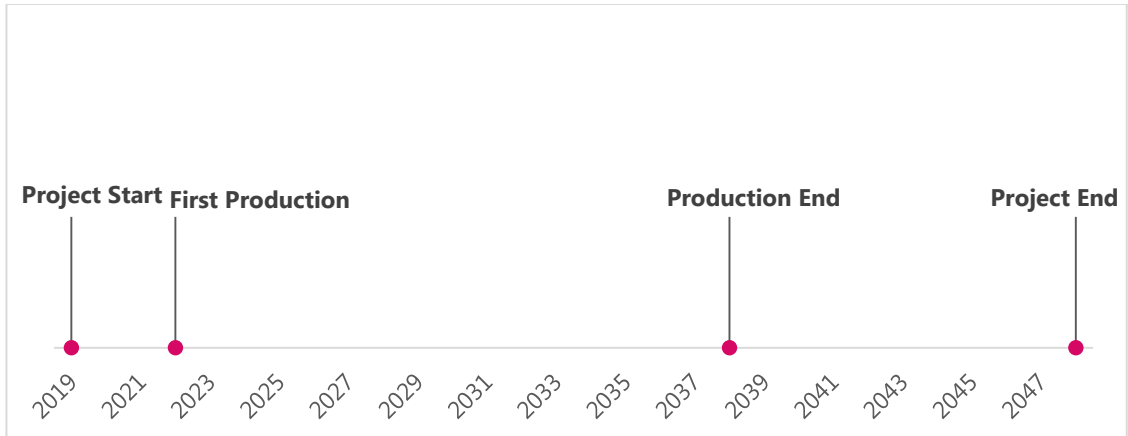
The accuracy and completeness of the financial model was ensured as follows:

- Two Advisian employees who were not involved in the development and population of the financial model performed a Competent Independent Review (CIR).
- Regularly testing financial assumptions with the broader project team and client.
- Reconciling (keeping track of) all changes in the financial model and reporting regularly on these variances. The logic and reasoning behind the changes were discussed and tested for reasonability.
- Spending time with various project disciplines to ensure that the information obtained from their workstream was interpreted and imported correctly.





Important dates in the Project’s LoM are shown in Figure 22-2 below:

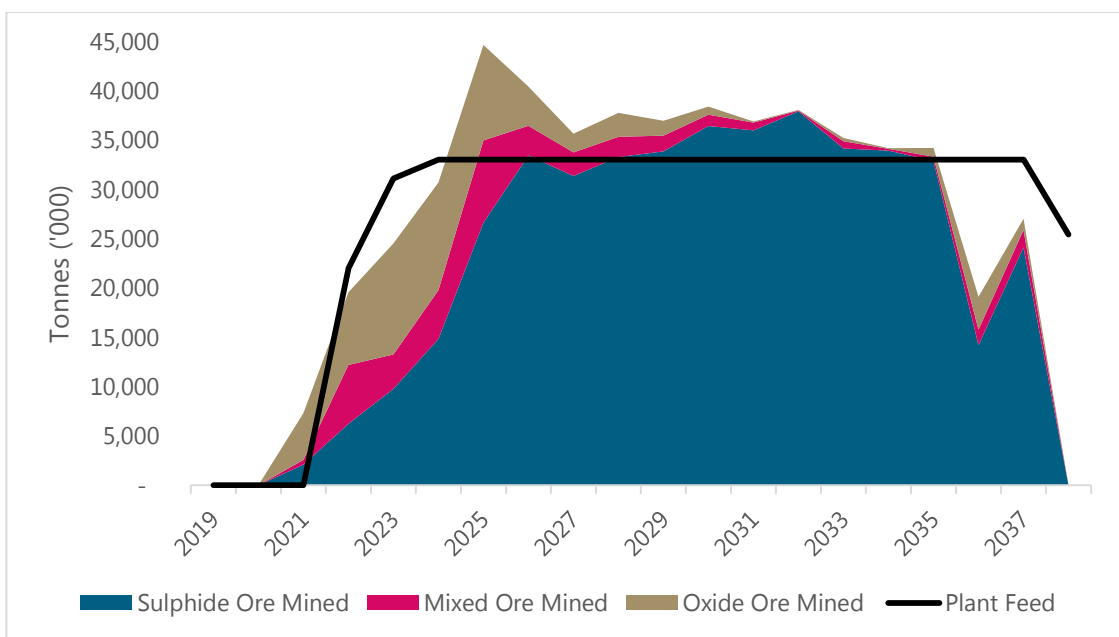


**Figure 22-2: Key Valuation Dates**

Figure 22-2 shows that project development will commence in January 2019, whilst first production and first revenue will be obtained in April 2022. The last year of production will be in 2038, which equates to a 20-year LoM from project start date and a 17-year LoM from first production. The project end date is 10 years after the production end date (2048) to account for an environmental rehabilitation and mine closure period.

### 22.2.1 Production Schedule and Processing Strategy

Mining operating costs are driven by total tonnes mined in the production schedule, whilst the plant feed profile influences most of the remaining operating costs e.g. milling and flotation. Figure 22-3 below illustrates the mining profiles for sulphides, mixed ore and oxides; together with the plant feed profile. Plant feed is capped at 33Mpta and additional ore is stockpiled until it can be utilised. Stockpiled below CoG sulphides attract a re-handling cost of USD1.0 per tonne throughout the LoM and stockpiled oxides between 2036 and 2038.

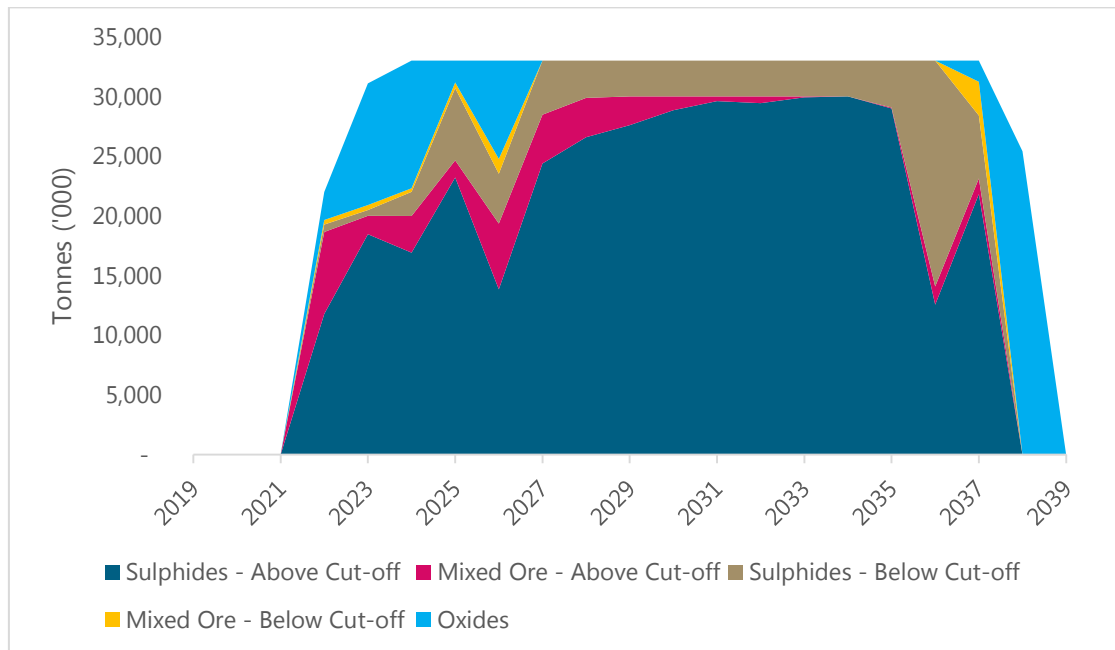


**Figure 22-3: Production Schedule and Plant Feed**



Mined ore is prioritised as follows for milling (see Figure 22-4):

- Sulphide ore above cut-off grade
- Mixed ore above cut-off grade
- Sulphide ore below cut-off grade
- Mixed ore below cut-off grade
- Oxide ore



**Figure 22-4: Prioritised Ore Feed**

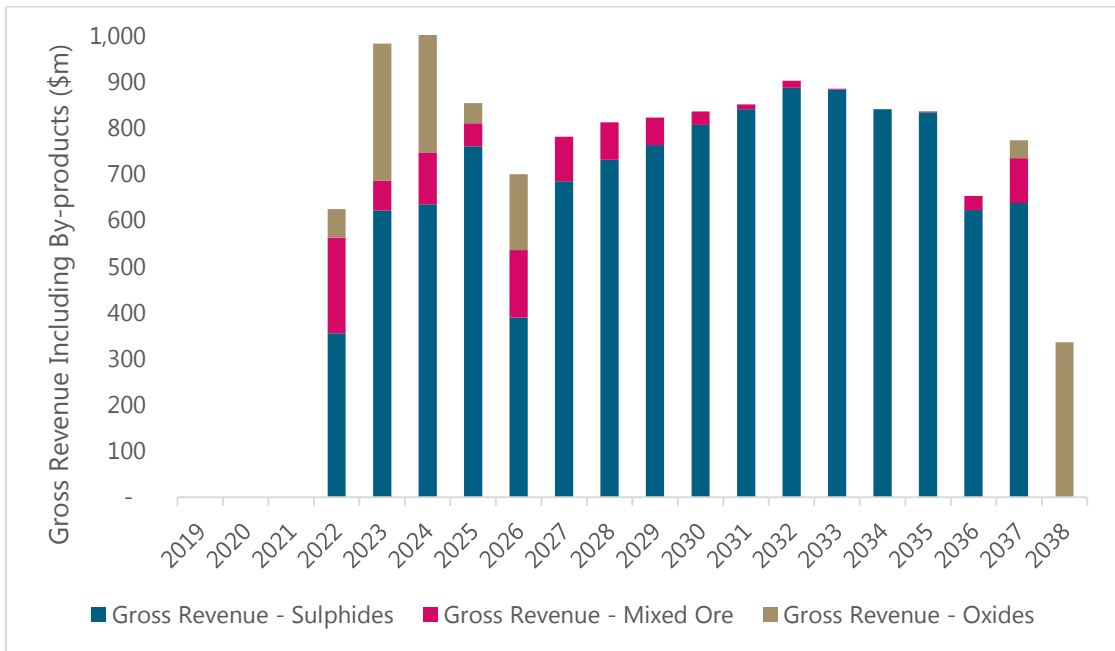
### 22.2.2 Revenue

Revenue calculations are based on plant feed tonnes, grades, recoveries, and commodity prices. The financial model tracks the grade and recovery associated with each tonne mined, for each geological domain, and each ore type. The characteristics of Cu, Au and Mo, for sulphide, transition and oxide ore therefore “follows” each ore tonne e.g.:

- Pit to plant.
- Pit to stockpile.
- Stockpile to plant.
- Stockpile closing and opening balances.

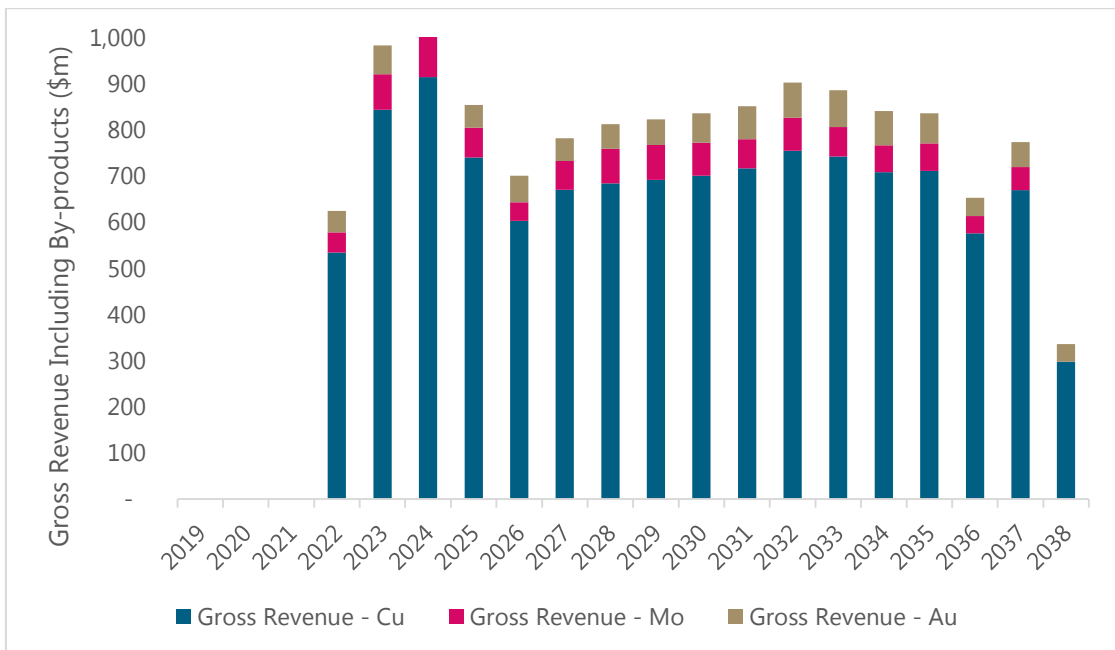
In addition, the financial model accounts for above- and below cut-off grade profiles. Please refer to Section 19 for commodity price and realisation assumptions.

Figure 22-5 below shows Yandera’s gross revenue, including by-products, over the LoM. The most revenue is generated by sulphide ore, followed by oxides and mixed ore.



**Figure 22-5: Gross Revenue including By-products**

Figure 22-6 shows the gross revenue per commodity type, over the LoM.



**Figure 22-6: Gross Revenue per Commodity Type**

### 22.2.3 Project- and Sustaining Capital

The basis of estimate for project capital is described in Section 21.1.

The valuation assumes that some of the Project capital will be funded by the PNG government or by other third parties. These costs are referred to as National Infrastructure and were excluded for valuation purposes.



**Table 22-3: Capital Estimate used for Valuation Purposes**

Description	Capital Excluding National Infrastructure (USD million)	Capital Including National Infrastructure (USD million)
Waste Rock Dump	30.7	30.7
Pre-development	289.3	289.3
Dewatering	14.6	14.6
ROM Tip & Crusher	8.1	8.1
Precinct Support Services	11.3	11.3
Precinct Infrastructure	109.0	109.0
Milling Plant	159.0	159.0
Yandera Camp	13.1	13.1
Power Supply - Intake Sub-station	4.2	4.2
Main Access Road	90.6	90.6
Diesel Storage Infrastructure	2.3	2.3
Slurry Pipeline	212.1	212.1
Flotation Plant	70.2	70.2
Mo Circuit	4.1	4.1
Coastal Facilities Infrastructure	20.6	20.6
Coastal Power Supply - Intake Sub-station	8.1	8.1
Wharf	40.9	40.9
DSTP	17.9	17.9
Camp	10.5	10.5
Coastal Facilities - Support Services	11.3	11.3
<b>Total</b>	<b>930.4</b>	<b>1,127.8</b>

Sustaining capital was calculated at 5% of total operating costs, excluding:

- Mining operating costs, as a contractor mining philosophy was applied.
- Milling and flotation costs, as these operating costs make provision for maintenance and minor replacements.

#### 22.2.4 Operating Costs

The basis of estimate for operating costs is described in Section 21.2.

A contractor mining philosophy was assumed for mining activities. Fixed and variable costs were accounted for in the financial model. Fixed costs will be incurred irrespective of production activities and variable costs will fluctuate in line with production.



## 22.2.5 Rehabilitation Costs

Mine total closure and rehabilitation costs are expected to amount to USD 107.16m over the LoM. An annual contribution will be made into a rehabilitation trust fund until production ends. The cumulative balance of allocated funds, together with additional costs, will be utilised for 10 years after mine closure.

The NPV is relatively insensitive to changes in rehabilitation costs as the costs are spread over the LoM. As an example, the NPV will only decrease by 2.2% if the closure cost estimate doubles.

## 22.2.6 Income Tax

Income tax was calculated in nominal terms, at a tax rate of 30%. A depreciation allowance of 25% per year was applied for allowable capital expenditure (ACE).

Tax losses may be carried forward for a period of 20 years; unlimited for primary production losses. Pre-production losses of USD 250m, before January 2019, were included in the tax calculation together with tax losses made before first revenue. It is expected that Yandera will start paying income tax in 2025.

## 22.3 Valuation Results

Four valuation scenarios were created, as shown in Table 22-4.

- Project, excluding National Infrastructure (Base)
- Project, including National Infrastructure (Base + NI)
- Applying spot commodity prices, excluding National Infrastructure (Spot)
- Applying spot commodity prices, including National Infrastructure (Spot + NI)

The following spot rates were applied in the valuation (16 October 2017):

- Cu USD3.23 /lb
- Au USD1,295.10 /lb
- Mo USD7.14 /lb

**Table 22-4: Valuation Results**

Valuation Metric	UoM	Project	Base + NI	Spot	Spot + NI
<b>NPV</b> <sub>7.8%</sub> (Real)	USD million	<b>1,038</b>	832	654	441
<b>IRR</b> (Real)	%	<b>23.5</b>	18.6	17.6	13.5
<b>Payback</b> (Real)	Years	<b>5yrs 8mths</b>	6yrs 6mths	8yrs 0mths	9yrs 4mths
<b>Project Capital</b>	USD million	<b>930</b>	1,128	930	1,128
<b>Cumulative Maximum Negative Cash Flow</b> (Nominal)	USD million	<b>896</b>	1,101	896	1,101
<b>C1 Cash Cost – LoM</b> (Real)	USD/lb	<b>1.99</b>	2.03	2.09	2.13
<b>C1 Cash Cost – First 5 years</b> (Real)	USD/lb	<b>2.20</b>	2.23	2.29	2.33



Valuation Metric	UoM	Project	Base + NI	Spot	Spot + NI
<b>Reserve</b>	million tonnes	<b>540</b>	540	540	540
<b>Cu Grade (LoM Average)</b>	%	<b>0.34</b>	0.34	0.34	0.34
<b>Au Grade (LoM Average)</b>	g/t	<b>0.07</b>	0.07	0.07	0.07
<b>Mo Grade (LoM Average)</b>	ppm	<b>102</b>	102	102	102
<b>Strip Ratio (LoM Average)</b>	ratio	<b>1.36</b>	1.36	1.36	1.36

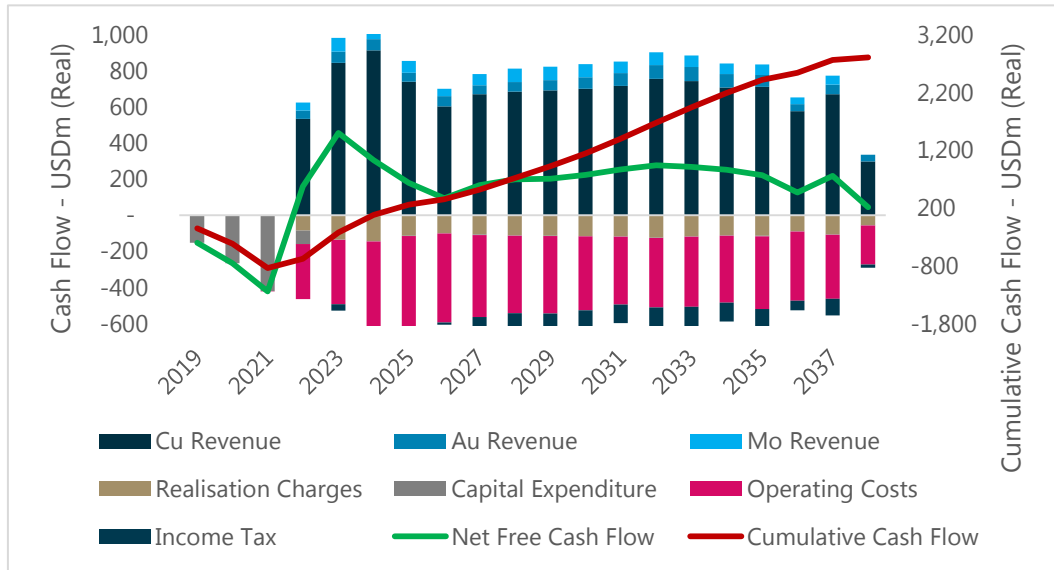


Figure 22-7: Annual Cash Flow

## 22.4 Sensitivities Analysis

The sensitivity analysis (see Figure 22-8) illustrates the impact on the NPV when an input is adjusted by 5% and 10%, whilst keeping other model inputs constant. The project NPV is the most sensitive to changes in revenue drivers e.g. commodity price, grade and recovery.

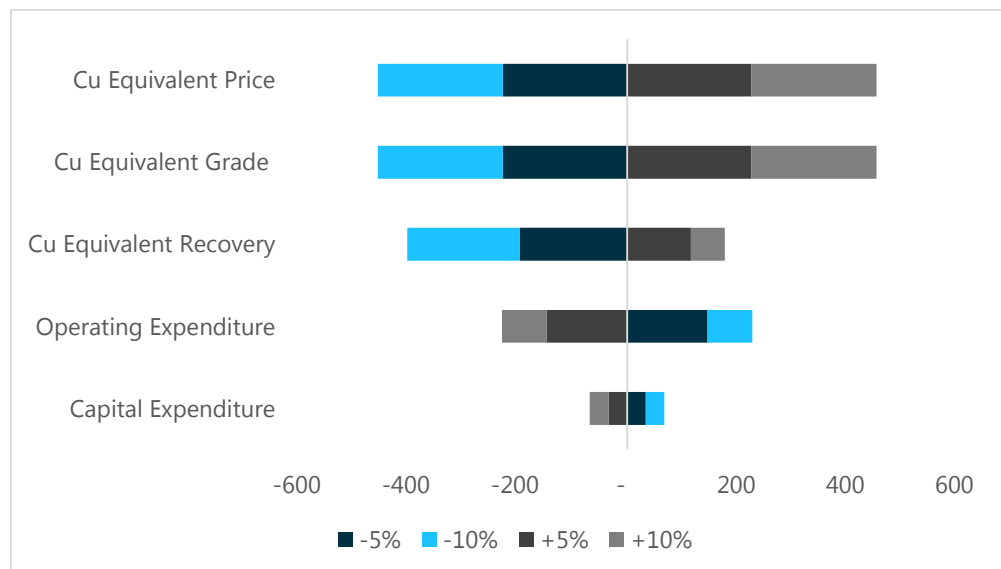






Figure 22-8: Sensitivity Analysis

## 22.5 Scenario Analysis

The valuation metrics are quite sensitive to changes in financial model inputs, due to the scale of the Project and grade of the deposit. This section explores an upside and a downside scenario, which could realise in future. It is unlikely that downside or upside conditions will apply for the entire life of mine, and as such, the scenarios only considered changes for a short period.

### 22.5.1 Upside Scenario

Table 22-5: Upside Scenario

Scenario Description	Scenario Assumption	Original Assumption	Impact on NPV (USD million)
The market analysis shows that there will be a period of short supply between 2022 and 2025, which will result in increased copper prices during this period. This scenario assumes that higher prices will be experienced for four additional years before it reverts back to the long-term mean of USD 3.30/lb.	Average of USD 3.72/lb between 2022 and 2029. USD 3.30/lb from 2030 onwards.	Average of USD 3.70/lb between 2022 and 2025. USD 3.30/lb from 2026 onwards.	+ 121
The study's market analysis showed that the gold price would fluctuate between USD 1,200/oz and USD 1,400/oz. Assume that USD 1,400/oz will apply for the first 5 years of production.	USD 1,400 for first 5 years of production; USD 1,300/oz thereafter	USD 1,300/oz for the entire LoM	+ 9
Assume that a more favourable solution is found for oxide ore and that copper recoveries will increase from 55 % to 60 %.	60 %	55 %	+ 28
Assume "China Inc." can reduce capital expenditure by 5 %.	5 % reduction in capital	-	+ 34
Assume "China Inc." can reduce mining Opex by 5 %.	5 % reduction in mine Opex	-	+ 57
<b>Combined Saving</b>			<b>+ 249</b>
<b>NPV Result</b>			<b>1,287</b>



## 22.5.2 Downside Scenario

**Table 22-6: Downside Scenario**

Scenario Description	Scenario Assumption	Original Assumption	Impact on NPV (USD million)
The market analysis shows that there will be a period of short supply between 2022 and 2025, which will result in increased copper prices during this period. Assume that additional supply from brownfields expansions will satisfy the increased demand and that the copper price remains at USD3.30/lb between 2022a and 2025.	Average of USD 3.30/lb between 2022 and 2025. USD 3.30/lb from 2026 onwards.	Average of USD 3.70/lb between 2022 and 2025. USD 3.30/lb from 2026 onwards.	-166
Assume that molybdenum prices will remain at the current spot price for the first 5 years of production.	USD 7.14/lb for first 5 years of production; USD 13.30/lb thereafter	USD 13.30/lb for the entire LoM	-63
Assume that favourable recoveries are not obtained for oxide ore.	Applied a 30% recovery for Cu oxides for the entire LoM	55% Cu oxide recovery	-132
Assume that capital expenditure increases by 5%	5% increase in capital	-	-36
Assume that only half of the National Infrastructure can be funded	Half of national infrastructure is funded by the project	-	-112
Assume that contract miners struggle with the operating conditions, resulting in an increase in mining cost	5% increase in mine Opex	-	-62
<b>Combined Saving</b>			<b>-571</b>
<b>NPV Result</b>			<b>467</b>



## 23 Adjacent Properties

---

There has been no exploration of interest in the properties adjacent to the Yandera EL 1335, in which the deposit has been modelled. The nearest mining activity is Ramu NiCo, a nickel-laterite operation also located in Madang Province approximately 25km north of Yandera. Ramu NiCo has its own coastal facilities at Basamuk. There is potential to share infrastructure with Ramu NiCo if Yandera advances to mining status.



---

## 24 Other Relevant Data and Information

---

There is no other data or information beyond that which has been described herein, which is relevant to this Report.



## 25 Interpretation and Conclusions

This section provides a summary of the relevant results and interpretations of information reported on in the PFS. Certain risks or uncertainties were identified that could affect the reliability and confidence of the information presented herein. An impact assessment of these risks on the project's viability was completed and mitigating factors were applied to manage these.

Results of this PFS demonstrate that the Yandera Project warrants development to a DFS stage to ensure that investment opportunities presented for approval are well defined, risks appropriately considered and that sufficient work has been completed to allow the investment to ultimately move into implementation.

It is the conclusion of the QP's that the PFS summarized in this technical report contains adequate detail and information to support a pre-feasibility level analysis.

The report authors are unaware of any unusual or significant risks, or uncertainties that would affect Project reliability or confidence based on the data and information made available. The path going forward must continue to focus on the acquisition of missing survey data, drilling and geotechnical investigation activities as well as obtaining the necessary permitting and land use approvals, while concurrently advancing key activities in the DFS that will reduce project execution time.

### 25.1 General

There are logistical, environmental and socio-political challenges for constructing and operating a mine in the remote highlands of PNG; including, steep terrain, high rainfall, poor infrastructure or the lack of access thereto, and private land ownership. The steep terrain and remote location pose both challenges and opportunities for mine development that will be addressed as the Project advances.

There are no material technical, environmental or socio-political obstacles to project development.

### 25.2 Mineral Resource

The estimate of Measured and Indicated Resources for the Yandera deposit in the highlands of PNG is approximately 728Mt at a grade of 0.39% CuEq, with contributions to the CuEq coming from low-grade Mo and Au. There is an additional 230Mt at 0.32% CuEq reported as Inferred Resource. The resource is reported within a potentially mineable open pit configuration. The majority of the resource is in sulphides, which recent metallurgical test work demonstrates is recoverable by conventional flotation to produce a concentrate. Of the total resource, approximately 8% of the tonnes reside in oxide, which is expected to have lower recoveries for each of the economic metals. Exploration is ongoing at Yandera, as well as further metallurgical, geotechnical and environmental characterization to advance the Project. In the author's <sup>(20)</sup> opinion Yandera is a project of merit warranting further study.

---

<sup>20</sup> Jay Pennington



## 25.3 Geotechnical

The main findings in the geological and rock engineering investigations that influenced mine design are discussed below:

- The general geotechnical conditions are suitable for the planned infrastructure and the soil and rock is capable of supporting the planned structures.
- The geotechnical database was adequate for this level of study but of insufficient depth and accuracy to base future work on.
- PNG is an area that experiences seismicity. This was taken into account for the pit slope design as well as the waste rock dump design.

## 25.4 Hydrology/Water Management

All three-project areas (mine area, Yandera to Cape Rigny Link, and Cape Rigny) receive between in the order of 3m to 5m of rainfall per year. This very high rainfall means that excess water needs to be managed in the pit and the WRD facility at the mine site. Measures also need to be implemented to prevent soil erosion and maintain land stability especially at the mine, WRD, along the link, as well as to limit exposure to or runoff from concentrate stockpiles at Cape Rigny port site facilities.

The mine area is located in an area of high relief with deeply incised and steeply sloping river channels. The primary source of water to be managed within the project area is from rainfall runoff. Groundwater is also a potential source of water, although the hydraulic properties of the bedrock in the area mean that the quantities available are expected to be relatively small.

The catchments of the Dengru and Mogoro Creeks, as well as the Yewago and Upper Tai-Yor Rivers are anticipated to be the most impacted, due to the concentration of mining and waste rock dumping activities in this area. For this reason, it is best for the water from these catchments to be used for make-up supply. Under exceptional dry climatic conditions, the make-up demand is greater than the supply; hence, all of the water will be used. However, under normal rainfall conditions some of the water will be excess to requirement and will require discharge to the environment following appropriate treatment to meet discharge standards

## 25.5 Mining Methods and Mine Design

Mining of the Yandera, copper deposit will be by surface mining. Blasting will be employed to break waste, ore, and electric shovels and diesel-electric trucks will be used for hauling.

The mine design and production schedules presented are deemed as reasonable for a PFS level of confidence. It is the view of the project study team that the layouts and schedule rates are appropriate.

## 25.6 Mineral Reserve

The confidence of the modifying factors applied to convert the geological resources into a reserve estimate, is at the level of a PFS.

In addition, the test work on oxide ore recoveries yielded inconclusive results.



These factors combine to result in the declaration of all the reserves in the reserve estimate as probable. When all the modifying factors are at a level of confidence representative of a DFS, the opportunity exists to convert the measured geological resources to proven reserves.

The Probable Mineral Reserves Estimate for the Project as at 27 November 2017 is summarized in the table below. The Mineral Reserves were determined in accordance with the requirements of the NI 43-101 Standards.

**Table 25-1: Total Probable Mineral Reserves Estimate**

Material	Probable Reserve Ore (kt)	Cu Grade (%)	Mo Grade (%)	Au Grade (ppm)	Pit Estimates (kt)
Oxide Ore	60,482	0.3365	0.0057	0.0819	
Sulphide Ore	441,040	0.3325	0.0107	0.0683	
Transitional Ore	38,975	0.3625	0.0107	0.0885	
<b>Total Ore</b>	<b>540,497</b>	<b>0.3351</b>	<b>0.0102</b>	<b>0.0713</b>	
<b>Total Waste</b>					<b>733,772</b>
<b>Total</b>					<b>1,274,269</b>
<b>Stripping Ratio</b>					<b>1.36</b>

## 25.7 Metallurgy and Processing

It is the opinion of the qualified person responsible for Section 13 of the technical report, Mr Marek Dworzanowski, that sufficient test work to support the Yandera PFS has been undertaken.

Bench scale test work conducted, on sulphide ore has demonstrated that a saleable concentrate containing at least 28% Cu can be produced. No deleterious elements are expected whilst Cu recoveries in excess of 93% are possible. Oxide ore is recoverable to a lesser extent by flotation and benchmarking is the primary source of recovery data for this study.

Sufficient test work has been undertaken to demonstrate sulphide recovery and to support sizing of major equipment components. The flowsheet selected is typical for similar ore types in the region.

## 25.8 Infrastructure

The Project requires both regional and local infrastructure to support mine development and operations. The main infrastructure requirements are access roads, a wharf at Cape Rigny, an ore slurry pipeline, tailings disposal, water management, power supply, waste rock dump, camp sites and local infrastructure to support the mine and milling precinct as well as the process plant and associated works to service and treat the targeted mine production.





Solutions have been identified to provide access during operations and construction, as well as provision for all facilities required to support the operations. A solution for power and water supply is identified as well as for export of product.

- Site access - approximately 50km of new or upgraded roads to be constructed as well as various new bridges at river crossings. Access to the coastal facilities at Cape Rigny is by purpose built barge and concentrate export will be done through a new wharf facility.
- Bulk Water Supply - The Yandera water balance indicates the Project water demand can be met from the surface catchments surrounding the mining infrastructure for a normal range of climatic conditions. Under drought conditions there may be a shortfall during the summer months, which can be mitigated. Bulk water supply to Cape Rigny operations assumes that sufficient volumes of raw water can be recovered from the slurry transportation pipeline for partial treatment and release for industrial use in the Cape Rigny operations. Potable water for Cape Rigny demands will be sourced from local ground water supplies.
- Power Supply - The bulk electricity supply for the Project is planned to cater for production rates up to 33Mtpa, which corresponds to an electrical load up to 225MVA. Temporary electrical supplies are planned for the construction stage at the respective construction sites. Permanent electrical power will be supplied by an Independent Power Generating (IPG) authority, which will also transmit the power to the Coastal and Mine Precinct respectively.
- Ore Slurry Pipeline - Pipeline transportation of the slurry from the Yandera mill to the Cape Rigny flotation plant is technically feasible. It has been proven that the system is reliable and environmental risk is manageable. Both capital cost and operating cost estimated in this Report indicate that, the large diameter slurry pipeline (approximately 146km long) is also economically viable.
- Deep Sea Tailings Placement – Although an environmentally sensitive option, the DSTP is a technically and economically feasible method for Yandera tailings disposal. The slope of the seafloor and the depth of the Vitiaz Basin provide unique technical advantages to minimize the impact of tailings disposal on the marine environment.

## 25.9 Environmental and Socio-economic Aspects and Permitting

Considerable environmental and socio-economic data and information have been collected for the project area in the last decade, considerably more than might be expected to be available at the stage of a project. This information, together with data collected from additional DFS proposed environmental and social studies will address significant data gaps and inform the preparation of the EIS for the Project. The EIS is required to obtain an environment permit for the Project.

Environmental values vary across the project area. Some sites, such as the mine area, have relatively low biodiversity values, due to a history of ongoing human disturbance. Socio-economic aspects in this area will need to be carefully addressed. Other areas of proposed project activity such as the access road and pipeline alignments would pass through relatively uninhabited areas that are sites of high biodiversity value, in particular the relatively intact forest of the foothills and Ramu River Valley.



The primary environmental and socio-economic aspects for the Project are:

- management of a very large volume of waste rock in a geo-technically stable facility;
- management of potentially acid forming material and AMD risks;
- sediment-laden runoff into the Tai-Yor catchment and subsequent downstream impacts to aquatic ecosystems and water resource use, particularly at Yandera village;
- opposition to DSTP at Cape Rigny from some stakeholders (e.g., coastal communities and NGOs);
- the environmental and socio-economic impact on the Yandera village;
- obtaining approval of the project EIS; and
- the granting of an environment permit with impractical and/or unachievable conditions.

## 25.10 Marketing and Contracts

The Yandera Project will develop a new and long-term copper resource that can supply both copper and molybdenum concentrates to world markets and thereby creating a platform for economic growth in Papua New Guinea. The project will have direct access to Asian markets as it is in relative proximity to Chinese ports from Madang.

The copper and molybdenum concentrates produced at Yandera is expected to be marketable and will have average to above average copper concentrate grades, low impurities, and payable precious metal credits.

A detailed market entry strategy will be developed during DFS. Offtake agreements will also be finalised as the Project matures during future study phases.

Various contracts should be in place before the property could be developed. Examples of possible contracts include construction, mining, concentrating, smelting, refining, transportation, handling, sales etc. Various government and landowners' agreements might also have to be in place. The DFS will unpack the detail of these contracts and will indicate possible timelines and stages of negotiation.

## 25.11 Financial Evaluation

### 25.11.1 Operating Cost

The operating cost estimate for the Project is done to an accuracy level that is acceptable for a PFS level. The average total cost amount to USD 12.92 per total tonne milled over the LoM of which the mining (including waste handling) contributes the most to the operating cost at 45% followed by the milling and flotation plant contributing another 44%. A breakdown of the cost by sub-activity determined that the major contributors to the cost are power and fuel.

### 25.11.2 Capital Cost

The Direct Cost Capital Estimate amount of USD 930 million to a PFS accuracy range of +19.26% to -10.98%. This estimate has been calculated without any indirect costs (contingency, insurances, EPCM costs, owner's costs, and forward cover).



### 25.11.3 Business Case

The Yandera project is expected to realise an NPV and IRR of USD 1,038m and 23.5% respectively, in real terms. A capital investment of USD930m is required, which will be paid back after 5 years and 8 months.

The financial returns will only be realised if National Infrastructure of USD 197m can be funded outside of the project (off the balance sheet); and if project development can commence in January 2019, to ensure that the mine can produce ore in the anticipated high-price cycle (2022 to 2025).

## 25.12 Risk

As part of the PFS project risk management process, a risk workshop was held to identify and assess risks related to the Project.

The key risks potentially impacting the achievement of the project objectives were identified, together with their root causes and potential consequences. Primary mitigating strategies currently in place to address the risks were documented and where the current risk rating was considered unacceptably high, additional action items agreed to reduce it to an acceptable level.

The objectives of the risk assessment workshop were to:

- validate the key risks associated with the PFS;
- discuss the risks identified and ensure common understanding of these risks amongst participants;
- prioritise the key risks using agreed criteria;
- Review mitigation actions for the key risks validated i.e. High or Extreme; and
- Identify potential new key risks associated with the PFS.

The risk workshop was structured around the following areas:

**Table 25-2: Risk Breakdown Structure**

Environmental	External	Project Management	Technical	Organizational	Occupational Risk	Sustainable Development
Biophysical – Air, Land, Water, Biodiversity, Economic Permitting	Legal Economic Regulatory Regulatory Geographic Local Infrastructure incl. Political and Country	Project Scope Cost Schedule/Time Human Resources Integration Communication Procurement Stakeholder Management Quality	Methods Construction Complexity Design Site Location Performance Technology	Strategic Financial Organization Resources Commercial	Safety Health Event	Social Culture Employment Community Land Owners Stakeholders CSI Heritage Sites Local Business



Environmental	External	Project Management	Technical	Organizational	Occupational Risk	Sustainable Development
		Risk Financial Contract Management Engineering Health & Safety	Operational Readiness			

Detailed operational risks associated with the engineering design e.g. Hazops and Design for Safety were excluded from the scope due to it being assessed via the normal project design review activities.

A total of 41 risks were identified to be assessed. Inherent risk ratings resulted in 4 Extreme risks, 18 High risks, 15 Medium and 4 Low risks. Key controls were put in place, and residual risk ratings resulted in 19 medium risks, 20 low risks and 1 risk was not assessed in more detail due to inherent low risk rating.

**Table 25-3: Overview of the Risk Categories of the Yandera Project**

Risk Categories	No. of Risks
Competition	
Customers	
Finance	6
Procurement	3
Operations	20
Risk & Compliance	1
Communication	
SHEQ	8
Human Resources	1
IT	
Fraud	
Legal	2
Emerging risk	
Not selected	
Reputation	
Project Team	
Resources	
<b>Total</b>	<b>41</b>

No risks had a residual Extreme or High Risk rating. The residual risk ratings all fell within the Medium or Low categories, thus requiring no further actions at this stage of the Project



### 25.12.1 Risks Identified

A risk workshop was facilitated with the project team to quantify identified risks. The highest ranking risks identified during these workshops together with the recommended following controls were defined as follows:

**Table 25-4: Highest Identified Risks**

Risk #	Risk Name	Root Causes to the Risk	Inherent Risk Exposure	Key Controls	Residual Risk Exposure
1	Extreme nature incidents	<ol style="list-style-type: none"> <li>Excessive rainfall</li> <li>Seismic event</li> </ol>	Extreme	<ol style="list-style-type: none"> <li>Monitoring</li> <li>Flood barrier</li> <li>Safe design</li> <li>Evacuation planning</li> <li>Safe Operational slope angle</li> <li>Detailed Geotechnical studies &amp; risk modelling</li> </ol>	Medium
2	Inability to meet early works construction schedule	<ol style="list-style-type: none"> <li>Duration for legal permitting</li> <li>Duration for Client / Project approval</li> <li>Contractor interfacing</li> <li>Change in funding or Strategy</li> <li>Materials/ equipment unavailability</li> <li>Inclement weather</li> <li>Incorrect scope</li> <li>Stakeholder engagement</li> </ol>	Extreme	<ol style="list-style-type: none"> <li>Selection of competent/approved contractors for tender purposes</li> <li>Effective contractor management</li> <li>Realistic planning rates</li> <li>Performance KPIs (Key Performance Indicators)</li> <li>Procurement Strategy</li> <li>Operational Readiness Plan</li> <li>PEP (Project Execution Plan)</li> <li>Early stakeholder engagement</li> <li>Continuous monitoring of permitting requirements e.g. EMP (Environmental Management Plan), SML (Special Mining Lease)</li> </ol>	Medium
3	Transporting of abnormal loads associated with local infrastructure	<ol style="list-style-type: none"> <li>Lack of a project logistics study</li> <li>Existing infrastructure</li> <li>Site location</li> <li>Magnitude of equipment of designs</li> <li>Size and weight of components to be transported</li> </ol>	Extreme	<ol style="list-style-type: none"> <li>Logistics study</li> <li>Equipment to be manufactured in a knockdown form</li> <li>Scheduling transport around dry season</li> </ol>	Medium
4	Risk associated with DSTP (Deep Sea Tailings placement)	DSTP (Deep Sea Tailings placement)	Extreme	<ol style="list-style-type: none"> <li>Stakeholder engagement</li> <li>Design compliance</li> <li>Use of reputable consultants</li> <li>EIA (Environmental Impact Assessment) and associated studies</li> </ol>	Medium
5	Sensitivity to other C1 cost drivers as a result of the project physical attributes of the metal grades, location and topography.	<ol style="list-style-type: none"> <li>Low grade</li> <li>Remote location</li> <li>Complex topography</li> </ol>	High	<ol style="list-style-type: none"> <li>Grade control</li> <li>Smart scheduling</li> <li>Continued exploration</li> </ol>	Medium



Risk #	Risk Name	Root Causes to the Risk	Inherent Risk Exposure	Key Controls	Residual Risk Exposure
6	Less favourable macro- economic conditions	1. Exchange rate 2. LME prices 3. Market position e.g. supply and demand	High	Forward hedging	Medium
7	Lower than anticipated recoveries	1. Lower than anticipated head grade 2. Oxidized RoM (Transition between oxidized ore and sulphide - definition & classification) 3. Changes in ore mineralogy 4. Fluctuation in head grades or process tonnage 5. Inefficiencies in processing plan	High	1. Flexibility in plant design incl. Modern equipment 2. Plant Operation i.e. training 3. Process control incl. grade control / ore type control 4. Possible blending of the ore 5. Continual communications with Mining & Geotech 6. Additional test work 7. Review plant design for ability to treat oxide sulphite blend	Medium
8	Milled slurry pipeline failure	Failure of the slurry pipeline system incl. all aspects of the pipeline due to technical or natural causes	High	1. Inspections 2. PM (Preventative Maintenance) 3. Spares holding 4. Geotechnical monitoring and assessments	Medium
9	Potential scarcity of mining contractor and rates	1. Remote location 2. Market supply and demand 3. Scale of the contract	High	1. Early engagement with potential Mining firms 2. Making use of the one belt, one road initiative 3. Practicality of access, mine design and production schedule	Medium
10	Congestion on site (construction)	1. Multiple contractors 2. Restricted work space 3. Tight schedule 4. Topography	High	1. Forward planning & scheduling 2. Early Contractor engagement 3. Contracting philosophy	Medium
11	In-migration of additional people	Perceived work opportunities	High	1. Social compact study 2. Stakeholder engagement 3. SIA (Social Impact Assessment)	Medium
12	Sediment / pollution risks downstream at Yandera mine	1. Mining operations 2. Uncontrolled runoffs 3. Spillage from various sources	High	1. Pollution control systems 2. EIS (Environmental Impact Studies) 3. Stakeholder engagement 4. Planning of site components 5. Drainage / diversion 6. SIA (Social Impact Assessment)	Medium
13	Exposure to emissions e.g. dust, noise, traffic	1. Construction activities 2. Operation activities	High	1. EMP (Environmental Management Plan) 2. Stakeholder engagement 3. Design 4. Monitoring systems 5. Compliance to COPs (Codes of Practice) and SOPs (Standard Operating Procedures)	Medium



Risk #	Risk Name	Root Causes to the Risk	Inherent Risk Exposure	Key Controls	Residual Risk Exposure
				6. TMP (Traffic Management Plan) 7. SIA (Social Impact Assessment)	
14	Land owner claims and disputes	Legacy issues	High	1. Stakeholder engagement	Medium
15	Not obtaining Environment permits or permit delays	<ol style="list-style-type: none"> <li>Changes in legislation</li> <li>Inadequate baseline data collection</li> <li>Engineering design changes during EIS process</li> <li>Disruptions due to landowner disputes and local community dissatisfaction with project</li> <li>Negative perceptions of DSTP</li> <li>Impractical permit conditions by Regulators</li> </ol>	High	<ol style="list-style-type: none"> <li>Appointing experienced Environmental consultants to manage approvals</li> <li>Conduct frequent Government &amp; Agency consultation</li> <li>Implement stakeholder engagement plan</li> </ol>	Medium
16	Lack of footprint area for spoil for external road construction	<ol style="list-style-type: none"> <li>Topography</li> <li>Large volume of surplus cut material</li> </ol>	High	<ol style="list-style-type: none"> <li>Identification of suitable spoil areas</li> <li>Stakeholder engagement</li> <li>EIA (Environmental Impact Assessment)</li> </ol>	Medium





## 26 Recommendations

---

The QP's have the following recommendations:

- Progress the Project to the DFS stage, during which the designs and cost estimates will be developed further to improve confidence and reduce risk.
- The DFS should take approximately 12 months and will prepare the Project for permitting and execution.
- Through a limited resource-to-reserve drilling and conversion programme, the mine life and project value could be significantly increased.
- Continue with stakeholder engagement at national and regional level to unlock infrastructure development synergies between the Project and national interest.
- Take cognisance of the forward work plans identified in this study to incorporate in the DFS.

### 26.1 Recommended Work Programmes

This section contains particulars of the recommendations for future work and a breakdown of costs where available.

#### 26.1.1 Exploration

##### 26.1.1.1 Resource Expansion

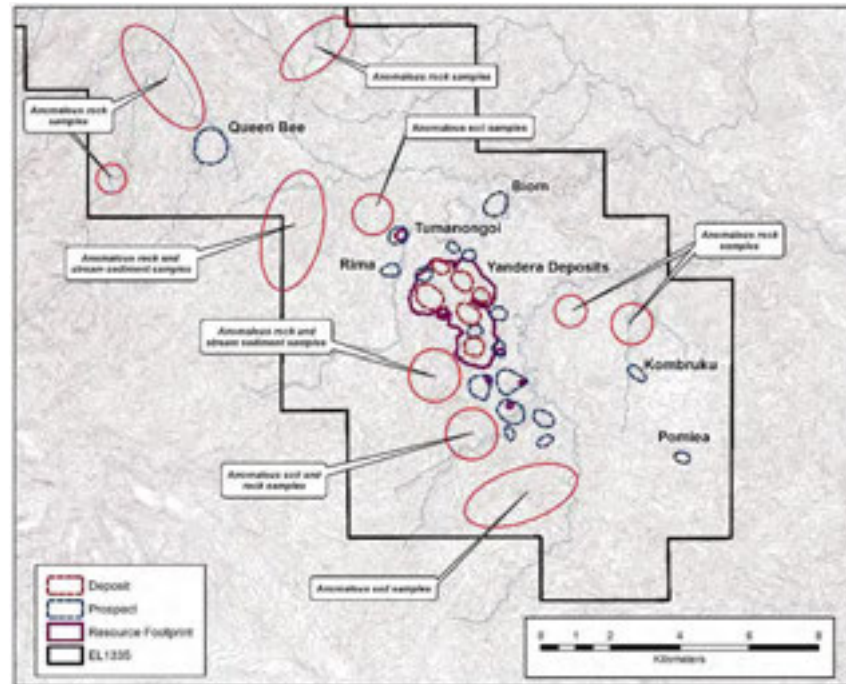
A number of areas have been identified within the potential future mining footprint that would benefit from additional drilling. These "conversion" targets have potential to improve economics at the next level of study by converting mineralized material to Resources or Resources to Reserves.

##### 26.1.1.2 Regional Exploration

Era is recommended to continue to carry out work on district exploration prospects to expand the resource. District exploration includes known prospects such as Rima and Frog. In parallel, Era could consider continuing to develop grass-roots exploration prospects through traditional targeting, mapping, sampling and drilling. Identified grass-roots prospects include Pomiea, Biom and Queen Bee.



Regional exploration targets are presented in Figure 26-1 below:



**Figure 26-1: Resource Potential along the North West / South East Strike**

## 26.2 Geotechnical

Based on the geotechnical report completed during the PFS, the following recommendations are made:

- Additional geotechnical information and geohydrological information is required to define the geotechnical constraints on the design at a level suitable for a DFS.
- A number of dedicated vertical boreholes should be drilled along the pit perimeter in areas where there is limited information and be geotechnically logged. In addition, a Standard Penetration Test (SPT) should be performed in the upper portions of the hole up to SPT refusal at intervals of no more than 3m to provide the required additional geotechnical parameters to optimize the design of the pit slopes in the oxidized zone.
- Packer tests (Lugeon or positive displacement) should be conducted in the boreholes to determine the permeability of the rock mass and, where possible, fracture zones that are intersected.

As part of the DFS, Packer testing should be conducted on selected boreholes close to the final pit positions defined in the PFS. The geology team on site is capable of conducting geotechnical logging; therefore, all boreholes drilled during the DFS campaign should be logged.



## 26.3 Hydrological Consideration

To address uncertainties in quantification of groundwater inflows to the open pits, the following works are recommended:

- Field studies to improve definition of rock and fault zone hydraulic properties, piezometry, and water quality.
- Refine groundwater inflow estimates for the LoM using numerical groundwater flow modelling.

Outputs from the numerical modelling can be used to provide pore pressure data for geotechnical modelling.

It is recommended that rainfall data and streamflow data continue to be collected at the site throughout all phases of the Project to support update of the rainfall statistics and design flood estimates. During next project phase, more detailed hydrological analysis should be undertaken to develop flood hydrographs for the catchments and model flood extents, depths and velocities. This information can be used to inform a project flood risk assessment and to design any necessary flood protection measures and river diversions.

To improve confidence in the water supply potential, it is recommended that more detailed rainfall-runoff models be developed for the contributing catchments and a dynamic water balance be developed to appraise water supply potential over the life of the Project, including water requirements during construction and commissioning. The impacts of climate change and extended drought periods should be incorporated into the dynamic water balance analysis.

## 26.4 Mining Methods and Mine Design

A number of optimization opportunities were tested during the PFS, including reducing the initial pit size to limit waste mining in the early years of the LoM and to access the relatively high grade ore as soon as possible. At PFS level, the three dimensional deployment strategy was planned, scheduled and proven to be practical via the block by block XPac animation.

The practicality of the production ramp-up between 2023 and 2024 needs to be confirmed to the appropriate level of detail in the next phase of study to confirm that the increase in financial benefits can be realised at DFS level.

Proving the practicality of executing this ramp-up is not perceived as a material risk to project's business case, as the mining operating costs for peak production years have been increased to mitigate the cost risk. In addition, the initial base case mining profile, with a more conventional ramp-up showed financial results to within 5% of the final evaluation.

To confirm the practical achievability of the PFS production profile for the initial years, it is recommended that a congestion simulation be conducted using haul road designs into the smaller pit footprints together with animated simulation to confirm the mining tonnage profile during DFS.



## 26.5 Mineral Reserve

Complete test work on oxide ore recoveries.

Get all the modifying factors to a level of confidence representative of a DFS, in order to convert the measured and indicated geological resources to proven reserves.

## 26.6 Metallurgical Processing

### 26.6.1 Sulphide and Mixed Ore Test Work

The objective of DFS test work is to obtain a thorough appreciation of the variability across the ore body and provide confirmation that the proposed process flowsheet is robust enough to cater for variability in the ore body and produce the required target concentrate grades and recoveries.

Key metallurgical drivers for economic recovery of revenue metals from the sulphide zone are Cu mineral species and pyrite distribution in the ore body. The forward work plan will aim to establish how these drivers will influence and impact upon minerals processing in the context of the LoM plan.

The impact of variation of copper concentrate grade on toll smelting due to variation in copper concentrate grade as a result of copper mineralogy variation and variability of pyrite content needs to be determined during feasibility phase. The same exercise will need to be done for the molybdenum concentrate.

The variability test work programme should include assessment of the correlation between recovery and ore type, and this needs to inform ore classification in the geological block model.

New metallurgical drilling will focus on Imbruminda as this is a large contributor to the resource and has limited existing drilling. The balance of samples required for the test work will be sourced from the existing core shed. Close interaction with geology and mining will be required to select samples which will provide “snap shots” of various time frames in the mining operation, and would include samples at various locations, depths and at various head grades. Additional scope of work will have the following objectives:

- Further Comminution studies.
- Ore characterization.
- Flotation characterization.
- Update recovery and concentrate grade models.

### 26.6.2 Oxide Ore Test Work

The objective of DFS test work is to obtain a thorough appreciation of the variability across the ore body and provide confirmation that the proposed process flowsheet is robust enough to cater for variability in the ore body and produce the required target concentrate grades and recoveries.



In the case of the oxide ore, understanding of mineralogical variability within this zone will be the most significant outcome of the Project, specifically as the presence of non-floatable copper may influence the potential to extract Cu economically.

The forward work plan includes:

- Ore characterization.
- Comminution studies.
- Flotation characterization.

A detailed work programme is included in Section 13.

### **26.6.3 Concentrator Design**

A number of value improvement opportunities have been identified during the PFS and should be considered as trade-off studies during the DFS stage.

#### **26.6.3.1 Optimized Mill Throughput**

The mill selection is based on the 80<sup>th</sup> percentile hardness data. When softer material is treated, there is an opportunity to increase mill throughput. The value of additional metal recovered would need to be traded off against the incremental capital needed to de-bottleneck other sections of the plant. The ore hardness variability per year should be linked to the mine plan and a review done of maximum throughput attainable per unit operation.

The effect on concentrate mass pull when operating the rougher circuit at higher density needs to be evaluated relative to the cost for additional cells.

#### **26.6.3.2 Slurry Pipeline Surge Tanks**

The current design makes no allowance for slurry storage should the slurry pipeline need to be drained in the event of an unplanned stoppage of the flotation plant. The current design considered bypass of the flotation plant directly to the DSTP system in the event that the pipeline requires draining. The cost of ownership of the surge tanks should be evaluated against the revenue loss and anticipated number of unplanned stoppages over the life of the mine.

## **26.7 Infrastructure**

### **26.7.1 Roads**

The following details the tasks that should be undertaken during the DFS design phase:

- Road Corridor Review – Further value engineering and consideration of an optimized corridor and road alignments for the access and haul roads may provide for a more viable and economical solutions.
- Topographic Survey Validation and Additional Topographic Data – The accuracy of the supplied LIDAR data is unknown and the data are incomplete or not readily available for use along parts of the road corridors. Additional LIDAR information should be acquired to fill the gaps in the currently available LIDAR database. Ground verification and field survey (especially at proposed bridge locations) should be undertaken at several locations



to establish the reliability and adequacy of the data. Full or partial ground surveys may be required depending on the quality of the available terrain data. It is anticipated that a number of detailed ground surveys will be also required in various locations to obtain additional and more detailed survey data where significant retaining structures appear necessary.

- Geotechnical and Materials Investigation – Comprehensive geotechnical and materials investigations should be undertaken as soon as possible along the entire length of the road corridors, at proposed bridge sites, at the proposed plant and precinct, at the wharf, at the proposed quarry sites, at potential borrow pit locations and at the two campsite locations to establish material properties, quantities and qualities to inform geotechnical and foundation designs, material type availability, construction cost, construction methodologies and schedules as all these matters are highly dependent on accurate geotechnical information.
- Seismic Assessment and Design – All proposed bridges, structures, retaining walls, cut and fill slopes and drainage components will need to undergo seismic assessment during the DFS to allow for the development of appropriate seismic risk design parameters for structural designs.
- Geotechnical Design – Geotechnical design of structures and slope stabilization is required during the DFS to allow reliable estimates to be prepared and a safe design to be prepared.
- Value Engineering of Selected Alignments – Despite a number of design iterations conducted, coupled to the inaccuracy of available topographical survey information, in many locations the proposed designs still require high structural retaining walls or extensive earthworks. In the DFS design phase, the horizontal and vertical alignments should be adjusted to reduce these where possible. Adjustment of the road geometry to facilitate cross-drainage of the road profile will also be incorporated in the value engineering study.
- Road Design refinement – Geometry, pavement type, road configuration, drainage and road furniture to a DFS level of detail and accuracy.
- Ramu River Migration Study – A detailed hydrology and river migration study is required to confirm the site selection process for the proposed bridge sites as well as the road horizontal alignment along the Ramu River floodplains.
- Hydrology studies – Detailed hydrological studies are required of all the major catchment areas along the route of the main access road to inform bridge and drainage structure designs.

## 26.7.2 Port

Given the lack of geotechnical information and the associated uncertainty on required depth of piled foundations as well as the most suitable construction technique, the conceptual design has been based on a set of assumptions based on experience with similar projects and will need to be reviewed when this information becomes available. A geotechnical offshore survey complementing the current one is needed in order to provide sufficient data for the detailed design.



### 26.7.3 Ore Slurry Pipeline

The following activities are recommended for further work of the ore slurry pipeline project:

- Slurry laboratory test to verify the assumed ore slurry properties
- Pipeline route reconnaissance and geotechnical survey for the sections away from Ramu Pipeline.
- Revisit the pipeline alignment and hydraulics when the mine access road design is finalized and pipeline geotechnical survey is completed.
- Field confirmation of the constructability of the choke stations and the pressure monitoring stations.
- More detailed engineering and cost estimate.

### 26.7.4 Deep Sea Tailings Placement

The following activities are recommended for the DFS of the DSTP project:

- Slurry laboratory test to verify the assumed tailings slurry properties.
- Detailed swath bathymetry on identified routes to finalize the route selection for DSTP outfall pipelines.
- Geotechnical survey at the mixing tank location to confirm constructability of the tanks and the spill containment pond.
- More detailed engineering and cost estimate.

### 26.7.5 Power Supply

Investigate opportunities of power regeneration from the High Angled Conveyor (HAC) and trolley-assist systems. Refine the power reticulation for the in-pit areas taking into account pit development stages throughout the LoM.

### 26.7.6 Water Supply and Management

To improve confidence in the water supply potential, it is recommended that more detailed rainfall-runoff models be developed for the contributing catchments and a dynamic water balance be developed to appraise water supply potential over the life of the Project, including water requirements during construction and commissioning.

The requirement for supplementary water sources and storage as well as water treatment for surplus water prior to discharge should be determined and incorporated into the design in the DFS stage.

### 26.7.7 Environmental Work Programme

This section outlines the recommended forward works programme to be conducted as part of the preparation of the EIS to address the environmental and social issues identified in Section 20. The objectives of each aspect of the programme are summarized, as well as the scope, timing and estimated costs for each of the studies in the works programme.





The additional studies will seek to address many of the identified uncertainties and gaps in the existing environmental and social data sets and will include:

- Building on the geochemical assessment of waste rock and ore to identify clearly the potential for AMD and its release to watercourses, and assessing the extent of potential downstream impacts of AMD on biodiversity values and water users.
- Characterizing the water quality and aquatic values of the receiving watercourses, particularly those draining from the mine area, in the Ramu River valley and along the Rai Coast, to understand the nature of potential impacts and required mitigation measures.
- Addressing the real and perceived impacts of DSTP on the marine environment through studies to characterize the existing environment and nature and behaviour of the DSTP discharge.
- Studies to document the nearshore and fringing reef condition, and to then assess the nature and extent of potential impacts on this nearshore environment.
- Confirming the biodiversity values of terrestrial habitats, particularly where project infrastructure passes through undisturbed primary mixed hill and mixed alluvium forest in the foothills and Ramu River valley.
- Further surveys to characterize potentially affected communities and identify potential for impacts such as the loss of land due to the location of project infrastructure, changes to watercourses downstream of the Project, reduced amenity from changes to air quality and increased noise, and in-migration to the project area.
- Development of a conceptual plan for the successful and safe rehabilitation and closure of the mine, with closure objectives developed in consultation with stakeholders.

The additional studies and assessments summarized above will be essential to providing sufficient information and evidence for regulators and other stakeholders to understand fully the potential environmental and social consequences of the Project and the measures to be implemented to avoid and reduce significant impacts.

### **26.7.7.1 Surface Water Quality**

The objectives of this study are to:

- Characterize the range of background water quality conditions in surface waters in order to inform an impact assessment.
- Establish the background range of suspended sediment concentrations and their variation with flow given that significant quantities of project-derived material are likely to report to the streams (due to the steep terrain at the mine site), particularly during construction. This will provide a basis for the prediction and assessment of load increases due to the Project.
- Characterize stream bed sediment quality in the potentially impacted areas.
- Provide a baseline against which future water and sediment quality conditions can be compared.



- The study scope includes the following tasks:
  - Continue the ongoing water and sediment sampling programme currently underway.
  - Conduct a “once-off” characterization survey along the infrastructure corridor downstream of the Ramu River confluence and from Ato to Cape Rigny at several representative locations. The survey will:
    - Take estimates of stream flow rates and hydrology characteristics.
    - Ask local residents about uses of water resources in the area.
    - Review Ramu Nickel mine monitoring data to assist with the characterization of these streams (if available).
    - Interpret the results including comparison with other relevant studies (especially monitoring results from previous monitoring for the Project between 2007 and 2011) and water quality standards/guidelines, and prepare a baseline water and sediment quality report.
    - Provide the findings as an input into the downstream impact assessment.

#### **26.7.7.2 Hydrology and Meteorology**

The objectives of this study are to:

- Characterize stream flow in the project areas and downstream.
- Build a suitable hydrological database for use in planning the project’s water supply and the mine’s water management scheme.
- Use the hydrological data to develop understanding of the assimilative capacity of the river systems in relation to contaminants that may be discharged from the mining operations and to inform the EIS downstream impact assessment.

This scope has commenced with monthly monitoring of hydrology and meteorology underway.

The study scope includes the following tasks:

- Continue the ongoing hydrology and meteorology monitoring programme.
- Provide the data as an input to the downstream impact assessment.

#### **26.7.7.3 Geochemical Characterization of Mine Wastes and Ore**

The objectives of this study are to:

- Geochemically characterize mine waste rock, tailing and ore, and determine the potential for acid generation and dissolution of contained metals.
- Determine the likely quality of leachate from waste rock dumps and ore stockpiles over time, including pH neutral drainage.
- Determine the need for selective handling and management measures for waste rock.
- Assess the suitability of waste materials to be used as an acid neutralizing resource and a substrate for revegetation.



- Identify implications for the Project associated with the management of acid and/or neutral mine drainage.
- Assess the quality of water seepage from the pit voids during operation and closure.
- Model the downstream water quality during project operations and post closure.

Between August and November 2017, a study was conducted in collaboration with SRK to investigate the acid generating potential of waste rock from the Dimbi and Gamagu pits. This will inform the DFS, in particular the cost implications for waste rock handling, waste rock dump construction and closure.

Further geochemistry investigations will be conducted as part of the EIS. This will include acid base accounting on selected ore, waste rock and tailing samples as well as geochemical modelling of downstream water quality.

#### **26.7.7.4 Oceanographic Profiling**

The objectives of this study are to:

- Define the natural range of the surface mixed layer and euphotic zone thickness (this is critical to determining the required depth of DSTP discharge).
- Determine whether upwelling occurs and, if so, the base of wind-driven upwelling at the site of the possible future DSTP outfall.

The study scope includes the following tasks:

- Continue the monthly upper ocean profiling (CTD monitoring) programme offshore from Cape Rigny.
- Conduct an upwelling assessment and determine the depth of the surface mixed layer and euphotic zone thickness based on the review of satellite imagery and the updated dataset of CTD data suitable for inclusion in the EIS.

#### **26.7.7.5 Characterization of Tailing Discharge**

The objectives of this study are to:

- Determine the characterisation of the tailing sample to biota in the water column and on the seafloor.
- Measure the physical properties of the tailing sample so its behaviour in seawater can be subsequently modelled.

Further laboratory test work will be required if newly proposed discharge scenarios differ significantly from that assessed previously.

The scope includes the following tasks:

- Liaise with Era and the DFS team to check whether the previously assessed tailing sample is still representative and relevant to the current project.
- Liaise with Era and the DFS team to determine whether any additional DSTP discharge scenarios are to be investigated compared to the 2012/13 flotation tailing sample (e.g., if the DSTP system is to accommodate mine water, tailing from a different processing



method, or if the representative orebody is significantly different to that assessed previously).

- If additional discharge scenarios are to be investigated, then:
  - Review the mass balance for the additional scenario and obtain a sample that is representative of the mass balance.
  - Engage a laboratory to analyse the physical and chemical properties of the sample (solids and liquids) (including after mixing with seawater – i.e., elutriate tests).
  - Compare the chemistry of the filtrate to PNG water quality criteria and international water quality guidelines.
  - Compare the chemistry of the solids (and pore waters) to sediment quality guidelines.
  - If the chemical analysis shows toxicants to be exceeding PNG criteria in the liquor, then conduct an eco-toxicological characterization programme that repeats the approach taken in 2012/13, whereby a suite of sensitive biota from a range of trophic levels (eight bioassays) are exposed to the sample.
  - If the chemical analysis shows toxicants to be exceeding guideline levels in the solids, then conduct an eco-toxicological characterization programme that repeats the approach taken in 2012/13, whereby chronic toxicity and bioaccumulation of the solids was tested by exposing benthic biota to the sample.
  - Prepare a report that presents and interprets the physical, chemical and eco toxicological results.

The nominal timing for this study is January to March 2018 in order for the findings to feed in to the EIS.

#### **26.7.7.6 Soil Characterization and Rehabilitation**

The objectives of this study are to:

- Characterize soils in the project area so that the need for selective handling and management of soil (including acid sulphate soils) can be determined and additional measures to avoid, minimise or mitigate adverse impacts upon soils and landform can be identified.
- Assess project impacts on landform and soil and outline a monitoring regime and conceptual rehabilitation plan to manage the impacts.

Scope

- The scope includes the following tasks:
  - Conduct desktop assessment of areas not previously assessed, including ASS desktop investigation along the Rai Coast catchment.
  - Conduct a field study to address any gaps from the desktop review. This will include sampling along the section of the corridor that is shared with the Ramu Nickel Project and assessment of soils, landform and geology along the Rai Coast between Ato and Cape Rigny.



- Prepare a soils and rehabilitation report and conceptual rehabilitation plan based on the 2012 report, updated mapping (to extend to the Rai Coast [Ato to Cape Rigny]) and any additional field investigations.

### **26.7.7.7 Sediment Characterization and Transport**

The objectives of this study are to:

- Predict mine-derived incremental increased loads to total suspended solids concentrations during construction, operations and post-closure.
- Predict mine-derived bed sedimentation in the downstream drainage and the nature and extent of its impact with respect to associated beneficial values.
- Assist in developing management and mitigation measures for identified impacts.

The scope includes the following tasks:

- Model the sediment generated from the waste rock storage area either by direct runoff, runoff from upstream catchments or as the result of handling and weathering of material in the dumps.
- Conduct waste rock weathering trials.
- Determine the volume, rate and characteristics of mine-induced sediment reaching the river system from all sources. Model the material released, particularly during pre-strip operations.
- Assess sediment transport potential of the rivers draining the impacted areas downstream of the mine (i.e., Tai-Ayo, Imbrum and Ramu rivers).
- Use the results from the sediment characterization and waste rock studies and assess the risk of particulate metal exposure to aquatic organisms (i.e. sediment metal bioavailability).
- Use these results and other data and observations to interpret the fate of mine and waste rock induced sediment in the river system and report the outcomes.
- Propose mitigation measures to manage fugitive sediment and sediment impacts. This will include developing a strategy (with timeframes) to store, handle and manage incompetent waste rock over the life of the Project and post-closure.

### **26.7.7.8 Downstream Impact Assessment**

The objective of this study is to assess the likely impacts of the Project on downstream surface water bodies within the project's area of influence, taking into account physical, chemical and biological considerations, and including socio-economic aspects where relevant.



The scope includes the following tasks:

- Identify the project component activities that are potential sources of impact and the issues associated with these impacts. This is to include consideration of potential stressors on receiving waters, i.e., their source, nature, concentration/load and mode of action, taking into account construction, operations and closure. Potential impacts to be considered include:
  - Physical impacts to aquatic ecosystems/biota (and associated resource use) due to TSS and in-stream sedimentation from disturbed soils and similar material.
  - Toxicological impacts to people and aquatic ecosystems/biota (and associated resource use) due to metals associated with disturbed soils and similar material.
  - Toxicological impacts to people and aquatic ecosystems/biota (and associated resource use) due to discharges of contaminated groundwater, pit water or other.
  - Impacts on aquatic ecosystems/biota (and associated resource use) due to altered hydrological regime as a consequence of the construction and operation of the tailing storage facility (if constructed) and other project components.
  - Additional impacts on riverine and lacustrine beneficial values that might be associated with other project components as agreed with Era.
- Identify the appropriate assessment framework, e.g., PNG regulatory requirements, IFC performance standards and/or Australian ambient water quality guidelines, and assessment end-points, i.e., the beneficial values of surface waters, which are to be protected.
- Collect and collate information relevant to the assessment, including sediment transport studies, groundwater studies, acid rock drainage studies (geochemical), soil analyses, water use studies, downstream water quality modelling results, metallurgical studies and data from on-going ambient water quality monitoring and aquatic biota monitoring.
- Describe the measures to avoid, minimise or mitigate potential impacts to receiving waters.
- Assess the residual impacts that the Project will have on receiving waters with respect to identified issues and beneficial values, taking into consideration management and mitigation measures.
- Outline locations and requirements of a monitoring programme to evaluate the success of mitigation measures and further inform the ESIA (if required).

#### **26.7.7.9 Groundwater**

The objectives of this study are to:

- Predict project-derived changes to local groundwater (i.e., depth, flow and quality) and the nature and extent of impacts on associated beneficial values.
- Assess residual impacts to groundwater associated with the Project.



The scope includes the following tasks:

- Review the following information (which is typical of the level of information required for EIS purposes) provided by groundwater specialists as part of the mining FS:
  - Groundwater quality and quantity.
  - Groundwater model for the Project. The predictive model scenarios will be designed to estimate: ranges of groundwater inflow to the project area as a function of mine position and timing for operational and post mining phases; the extent of the zone of depressurization and drawdown; recovery of the groundwater system post mining; and the behaviour of waste rock storages/stockpiles and their influence on the surrounding groundwater systems.
- Identify beneficial uses and values associated with groundwater.
- Predict the potential impacts to groundwater beneficial uses and environmental values.

#### **26.7.7.10 Freshwater Aquatic Ecology**

The objectives of this study are to:

- Characterize the existing freshwater ecology environment downstream of the Project.
- Assess the likely impacts to beneficial values associated with the freshwater environment.

The scope includes the following tasks:

- Conduct a brief desktop study of freshwater ecology in those areas not assessed in previous work in 2012/13.
- Conduct a targeted field survey to characterize freshwater aquatic ecology in areas not investigated previously (i.e., from Ato to Cape Rigny).
- Prepare an impact assessment report suitable for inclusion in the EIS.

#### **26.7.7.11 Terrestrial Ecology**

The objective is to determine whether the construction and operation of the Project will affect:

- Terrestrial or riparian fauna species or faunal habitats of conservation significance or of significance to the local communities.
- Floristic and structural composition, areas of uncommon vegetation, or the ability of the local communities to exploit bushland resources.
- The scope includes the following tasks:
  - Conduct desktop review of any terrestrial ecology surveys between Ato and Cape Rigny conducted by others.
  - Conduct a targeted field survey campaign to address any areas not covered by previous flora and fauna assessments by 3D Environmental or other consultants for the Ramu Nickel Project or information from literature. Any field survey should focus on recording areas of ecological sensitivity and endangered flora and fauna.





- Characterize vegetation diversity and cover in the region from Ato to Cape Rigny along the Rai Coast.
- Prepare a Terrestrial Vegetation, Fauna Study and EIA suitable for inclusion in the EIS.

### **26.7.7.12 Noise and Vibration**

The objective of this study is to determine the impacts of the Project with respect to noise, ground vibration and blast overpressure both during construction and operations.

This scope will include preparing a report that largely draws upon the existing assessment (from 2013) to:

- Reflect any changes to the previously modelled noise emissions because of the new project description.
- Assess noise impacts due to additional sources and additional locations compared to the previous assessment (i.e., from Ato to Cape Rigny) and conduct noise modelling for the processing plant at Cape Rigny.
- Reflect the current project information (e.g., equipment, mining methods, infrastructure locations, and construction activities) with regard to noise and vibration sources and emissions.
- Incorporate findings of a desktop review to obtain any existing ambient noise data relevant to the Ato to Cape Rigny area (including data from baseline monitoring conducted by others at other coastal villages in PNG).
- Assess the option of using previously obtained SLR ambient noise data as the basis for characterizing the Ato to Cape Rigny area in terms of baseline noise levels.
- Update the noise modelling and the calculations of ground vibration levels and revise the impact assessment.

### **26.7.7.13 Air Quality and Greenhouse Gas**

The objectives of this study are to:

- Describe the existing air quality of the Project footprint and surrounds, including the sensitivity of receptors.
- Determine potential, credible air quality impacts associated with all phases of the Project.
- Identify appropriate management and mitigation measures and assessed credible residual impacts.
- Estimate greenhouse gas emissions for the revised project description.

The scope includes the following tasks:

- Review the revised project description to identify changes in the potential air emissions sources and compile the relevant activity data to enable the emission estimates to be revised.
- Review the latest climate data to see if any model parameters (e.g., wind direction and speed) need to be updated.



- Review the sensitive receptors (46 sensitive villages) against which impacts were previously assessed and confirm relevance with new project and any demographic changes.
- Investigate whether the existing ambient air quality data for the Project can be used to characterize the ambient air quality along the pipeline route from Ato to Cape Rigny and the project area at Cape Rigny. Alternatively, characterize the ambient air quality by using data from baseline monitoring conducted by others at other coastal villages in PNG.
- Estimate the air emissions from project activities and revise the atmospheric dispersion modelling to simulate the dispersion of these emissions downwind (taking into account the local topography and meteorology) in order to estimate maximum ground level concentrations at nearby sensitive receptors.
- Recalculate greenhouse gas emissions based on the revised project description to account for changes in disturbed areas, fuel consumption, waste generation, etc.
- Prepare an air quality impact assessment report based on the above factors and the new project concept.

#### **26.7.7.14 Archaeology and Cultural Heritage**

The objectives of this study are to:

- Characterize the archaeology and cultural heritage of the project area.
- Determine related sites or values that may impose constraints on the location of project facilities or may be impacted by project activities.
- Develop management and mitigation measures for archaeology and cultural heritage.

Revise the preliminary cultural heritage survey report by:

- Conducting a desktop review of previous archaeological, anthropological, linguistic, environmental and geographical records pertinent to understanding the archaeology and cultural heritage of the current project area that was not assessed in the previous work. This area is likely to be only the infrastructure corridor between Ato and Cape Rigny. Cape Rigny itself was assessed previously. The desktop review will also include reviewing the archives and associated documentation in the PNG National File of Traditional and Prehistoric Sites.
- Characterizing the archaeology and cultural heritage of the project area between Ato and Cape Rigny and determining related sites or values that may impose constraints on the location of project facilities, via a desktop study.
- Conduct an archaeology and cultural heritage impact assessment, which outlines mitigation and management measures for the avoidance and management of archaeological and cultural heritage arterial for inclusion in a project CHMP.

The scope of work does not include "pre-clearance" surveys, which will be required prior to project construction.



### 26.7.7.15 Land and Water Resource Use

The objectives of this study are to:

- Characterize land use by local people near, and downstream of, project facilities.
- Identify the range of bush materials that are used by local communities.
- Determine whether the Project will significantly affect the ability of the local community to exploit resources.
- Assess how demographic changes and project activities may influence the availability of resources.
- Rate the relative importance to local people of each resource.
- Accurately understand land ownership and use, and connection to land in the project area to identify potential project impacts and sensitivities about land ownership and use, and to assist with the siting of project facilities and land access arrangements.

Note: This assessment may also contribute to land negotiations and inform impact mitigation, compensation and community development strategies, in addition to options for the potential relocation of housing and settlements (i.e., processes outside those under the Environment Act 2000).

The scope includes the following tasks:

- Conduct a marine resource use survey at Cape Rigny. This will include interviews with locals and visits to local markets to determine fish species traded.
- Review any relevant land and water resource use survey information from the Ramu Nickel Project along the Rai Coast from Ato to Cape Rigny.
- Review how demography may have changed in the Cape Rigny area due to influences such as the Ramu Nickel Project – in particular, employment opportunities, changes to populations and gender ratios.
- Revise the existing Coffey 2012 report to include the findings from the additional marine resource use survey data at Cape Rigny, land and resource use data collected by Era, the land and water resource use data collected at Lila in 2011; information from the “once-off” water and sediment characterization survey and the fisheries assessment.

The nominal timing for this study is January to March 2018 in order for the findings to feed in to the EIS.

### 26.7.7.16 Landscape and Visual Amenity

The objectives of this study are to:

- Characterize the existing landscape character and visual amenity at key project locations after the identification of nearby sensitive receptors and key attributes of the landscape and amenity of affected areas.
- Identify potential impacts on sensitive receptors as they relate to landscape character and visual amenity associated with construction and operation of the Project.
- Assess residual impacts on landscape character and visual values associated with construction and operation of the Project.



Using the previous assessment as a basis, prepare an updated assessment by conducting the following tasks:

- Review the new project layout including facilities at Cape Rigny.
- Liaise with Era and project engineers to obtain data concerning final landforms (e.g., pit, processing plant, mine waste dumps, port facilities and pipeline).
- Prepare visual modelling (computer-generated photomontages) for the project facilities, illustrating how they would be seen from selected viewpoints (likely about six viewpoints) over time. The visual modelling should be in a format suitable for stakeholder consultation presentations (government departments (provincial and national) and local communities).

### **26.7.7.17 Health Impact Assessment**

The objectives of this study are to:

- Describe the environmental health risks of the Project.
- Assess residual environmental health risks to communities associated with the Project (i.e., impacts that remain following the effective implementation of management/mitigation measures).

The scope includes the following tasks:

- Review any relevant data from Era health and safety reports including any data from the Yandera health clinic.
- Review any new data from Era Community Affairs team regarding any recent social surveys in relation to health survey information.
- Conduct a health and dietary habits survey along the Rai Coast from Ato to Cape Rigny.
- Conduct a desktop review of health studies for other DSTP projects.
- Conduct a brief desktop literature review to check for any recent changes to guidelines, terms or reference or health statistics.
- Examine the human exposure to contaminants in food as a result of DSTP, drawing upon the findings of such relevant studies as:
  - Deep slope fish survey (and market fish survey) and tissue analysis.
  - Marine resource use survey.
  - Chemical characterization of tailings.
  - Dispersion modelling of tailings plumes and deposition.
  - Socio-economic baseline study.
- Identify food contaminants of concern.
- Develop a deterministic pathway model for human exposure (i.e., bioaccumulation of contaminants via the food chain and subsequent consumption).
- Prepare a health impact assessment technical report for inclusion as an appendix to the EIS.



### 26.7.7.18 Socio-economic Impact Assessment

The objectives of this study are to:

- Characterize the existing socio-economic environment.
- Identify the social factors that may pose constraints in terms of the siting of project facilities and/or which may otherwise require particular management.
- Identify the potential negative social impacts associated with the Project and develop methods for managing these risks.
- Identify the potential positive socio-economic benefits resulting from the Project and develop strategies for maximizing those benefits, primarily for project-affected stakeholders.
- Inform the proponent of opportunities to achieve optimal socio-economic development outcomes.
- Assist decision-makers and project stakeholders to assess whether the changes that the Project will bring to the social environment are acceptable and, if the Project proceeds, to ensure it does so in a way that results in lasting benefit for local communities.

To update the socio-economic impact assessment the required tasks are:

- Liaise with Era Community Affairs team to obtain any social survey data collected since 2012.
- Collate and review the social survey data collected at Lila.
- Review the other updated relevant studies that inform the SIA (health and nutrition study and resource use study).
- Collect additional data on landowner groups; including village statistics, cultural, social and economic data cultural heritage relating to Kurumbukari and along the pipeline/road route, particularly in the Rai Coast area.
- Conduct a macro-economic impact study. This should discuss the economic aspects of the Project and how they relate to drivers (direct and indirect) in the local, provincial, regional and national economies. The study should also assess potential direct and indirect economic impacts on the local, provincial, regional and national economies during the course of construction, operation and post-operation phases of the Project.
- Revise the existing SIA to reflect:
  - New project description.
  - New project location and impacted receptors.
  - Updated findings from the updated health and nutrition study; and the updated land, freshwater and marine resource use survey.
  - The findings of the macro-economic impact assessment.
  - Any additional social data provided by the Era Community Affairs team.



### 26.7.7.19 Assessment of Land-based Tailing

The objective of this study is to assess the suitability (from a feasibility and environmental and social impact perspective) of an on-land tailing storage option.

The scope includes the following tasks:

- Liaise with Era and its DFS team to ensure that sufficient investigation is conducted into on-land tailing storage options to support the inclusion of an ESIA of these options in the EIS.
- Review the on-land tailing storage investigations (including FSs and geochemical characterization of tailing) from the current phase of work along with previous work and describe the findings in the EIS document (project description section).

### 26.7.7.20 Conceptual Mine Closure and Rehabilitation Plan

The objective of this study is to formulate a conceptual mine closure and rehabilitation plan that is:

- Both technically and economically feasible and addresses the process by which stakeholders can comment and have input into the closure planning process.
- A basis for subsequent reviews and updates throughout the project life, culminating in a detailed closure plan as mine closure draws near.

The scope involves the review of the current project description and updating of the existing draft report by conducting the following tasks:

- Reviewing the latest policy, legislation, standards and guidelines regarding mine closure and developing appropriate standards that are consistent with leading practice, based on this review.
- Revising the preliminary end use objectives for the study area, with particular focus on the waste rock dumps and the project infrastructure from the perspective of potential beneficial uses for stakeholders post-closure (as far as is practicable).
- Revising the conceptual mine closure plan that addresses, in particular, the following:
  - A conceptual mine closure schedule.
  - Materials management, e.g., stockpiling and land forming.
  - Infrastructure decommissioning and removal.
  - Recommended stakeholder involvement in the closure planning process.
  - Modelling of final pit water quality, with a focus on whether water treatment is likely to be required post-closure to meet ambient water quality criteria.
  - Identification of the key issues for closure of the Project (both biophysical and socio-economic) that are consistent with the project's EIS. An action plan to address the risks and meet objectives will also need to be developed.
  - Preliminary end use objectives (as identified above) and indicators to meet these objectives.



- Post-closure residual impacts of the mine and other project infrastructure on the biophysical and social environments, assuming the implementation of mitigation and management measures agreed with project engineers.
- Ongoing post-closure management and monitoring programme for the Project (both for the biophysical and social environments).
- A preliminary estimate of mine closure costs and details of assumptions underlying the mine closure cost estimate (noting that this will not be reported in the EIS, but in the DFS).
- Revising the recommendations for management measures to reduce impacts on the biophysical and social environments post-closure of the Project. In particular, provide early advice on the arrangement and design of the Project that may assist with the closure planning process, and take into consideration the need for progressive rehabilitation where possible.

### 26.7.7.21 Ocean Current Measurements

The objective of this study is to measure the ocean currents near the DSTP outfall to inform outfall design and plume dispersion modelling.

No additional site-specific data collection is proposed for this scope. The scope of the long-term ocean current measurement programme involves the following tasks:

- Review the databases from the previous ADCP monitoring programme offshore from Cape Rigny and determine/measure the following:
  - Horizontal currents near the outfall terminus to determine current forces on the pipeline (for use in outfall design).
  - Bottom currents in the region of probable tailing deposition and determine whether the currents are sufficiently strong to resuspend deposited tailing (based on the results of the physical tailing test work described in Section 20.1.112, or new test work if required).
  - Vertical currents throughout the water column and assess the possibility of tailing rising through the surface mixed layer and potentially to the surface.
  - Horizontal currents throughout the water column and determine whether current shearing occurs, and provide a basis for detailed modelling of post-discharge dispersion and dilution of the tailing.
- Update the relevant sections of the Preliminary Oceanographic Analysis prepared by Coffey in May 2011.

Given the monitoring work completed to date and the fact that ocean currents are not expected to change vastly over time, this study is limited to a desktop review and compilation of existing ADCP data.





### 26.7.7.22 Nearshore Marine

The objectives of this study are to:

- Characterize the existing conditions of water, sediment, habitats and any environmental sensitivities within the potential area of impact in the nearshore marine environment.
- Assess project impacts to the nearshore marine environment at Cape Rigny.

The scope includes the following tasks:

- Review the existing coral reef and fish transect data held by Coffey.
- Review the land and water resource use database (held by Coffey) to obtain any information relevant to marine resource use at the nearshore marine environment at Cape Rigny.
- Conduct a field study to collect measurements of nearshore water quality and sedimentation and to assess the condition of fringing reefs. Era personnel will continue ongoing monitoring and data collection.
- To support the assessment, review the findings from the marine resource use survey proposed in Section 20.1.122.
- Prepare, directly into the EIS document, a characterization of the nearshore marine environment at Cape Rigny and assessment of potential impacts.

### 26.7.7.23 Fisheries Assessment

The objectives of this study are to:

- Assess the fish and fisheries resources that may be affected by the Project.
- Quantify the metals content of the fish tissue. This will provide a basis against which operations monitoring can be compared in order to detect impacts.

The tasks associated with these two scopes of work are summarized below:

- Fisheries assessment
  - Review the findings from the 2011 marine resource use interviews at Lila and Cape Rigny.
  - Review the land and water resource use study and database (held by Coffey) to obtain any information relevant to marine resource use at Cape Rigny.
  - Conduct a desktop assessment of the main marine zones, identification of existing and potential fisheries, identification of recreational dive sites and sensitive locations/habitats including those of endangered marine wildlife.
  - Supplement the assessment with opportunistic interviews and observations the marine resource use survey and deep-sea fish survey.



- Deep-sea fish sampling
  - During the marine resource use survey (see Section 20.1.122), obtain samples of fish sold at the market and analyse tissue for metals content.
  - Conduct a deep-sea fishing survey (to about 800m depth) offshore from Cape Rigny, which will:
    - Record actual catch rates (including catch per unit of effort and total numbers).
    - Record vertical distribution of fish catch.
    - Photograph, identify and weigh fish samples.
    - Measure the fish tissue (muscle and liver) metal content of a range of fish species (heavy metals per unit fish weight).
  - Compare data to food standards.
  - Compare findings to other DSTP deep slope fish studies and trophic ecology studies.
  - Prepare a summary report suitable for impact assessment purposes and to support the EIS.

#### **26.7.7.24 Ocean Floor Sediment**

The objective of this study is to characterize the ocean floor sediments so that impacts to benthic biota can be assessed and a baseline established against which future monitoring can be compared to measure impacts.

Ocean floor sediment was collected offshore from Cape Rigny in January 2012. The sampling included sites within potential DSTP deposition zones as well as reference sites away from these zones. This scope does not propose more sampling.

The task will be to update the existing Coffey deep-sea sediment-sampling survey report to incorporate the findings from a desktop review of findings from other benthic assessments of DSTP projects (including studies conducted by SAMS).

#### **26.7.7.25 Dispersion Modelling**

The objective of this study is to model the behaviour and dimensions of the DSTP discharge density current, subsurface plumes and deposited tailings in the marine environment over the mine life.

The work requires data review and modelling. The following data will need to be reviewed and inserted into the model:

- Oceanographic studies – ocean profiling (including the upwelling assessment) and ADCP current measurements.
- Meteorological data.
- Bathymetry data.
- Physical (including settling rates, re-suspension behaviour, specific gravity of liquors and particle characteristics), chemical (i.e., physico-chemistry, metals and ions) and eco toxicological tailings investigations.



- Mass balance information on the proposed DSTP discharge scenario(s).
- DSTP engineering design and the required mass balance inputs.

The model will then need to be developed and tested and will include the following tasks:

- Test the model (including sensitivity analyses) by conducting preliminary density current flow-path modelling.
- Validate the model (flow path and deposition) using known results from other projects.
- Run the dispersion model (including near field and far-field modelling) and determine the point at which the required number of dilutions will be met to meet PNG (or other) water quality criteria.
- Prepare a report that describes the method, inputs, assumptions, results and interpretation of the modelling of the DSTP plumes, density current and tailing deposition.

**Note:** DFS-level engineering design and costing of the DSTP system must be done before this modelling can be completed.

#### 26.7.7.26 DSTP Impact Assessment

The objectives of this study are to:

- Demonstrate that the oceanographic setting within the Vitiaz Basin is sufficiently well understood so that avoidable problems with the construction, operation and management of the DSTP system have been comprehensively anticipated and pre-empted by appropriate engineering design and the proposed DSTP system can be constructed and operated both safely and reliably over its expected design life.
- Assess the physical and chemical impact of the proposed DSTP discharge on the ecology and resources of the deep sea (including demersal fishery resources), the ocean water column (including pelagic and deep-sea fishery resources) and the benthic environment (including benthic biota and any benthic-pelagic coupling).

The scope includes the following tasks:

- Review the PFS-level DSTP design information.
- Review all the relevant baseline and impact assessment reports, including the tailing characterization data (physical, chemical and eco-toxicity studies), oceanographic findings (ocean profiling, upwelling and currents), modelling results, deep slope fish and resource use, and ocean floor sediment characterization.
- Collate all the findings and present them in a comprehensive impact assessment report that addresses PNG requirements, IFC guidelines (where applicable), SAMS guidelines and any other relevant criteria. Findings from the report will be used with the EIS document.
- Investigate deposition footprint of DSTP discharge and determine if it overlaps with the Ramu Nickel Project.



## 26.8 Financial/Business Case

The project returns are very sensitive to fluctuations in copper equivalent prices. Due to the project scale and ore grade characteristics, a reduction in the price received will have a significant impact on the valuation metrics. A high-price cycle is expected in the early years of ore production (2022 to 2025) and it is imperative that ore is produced in this period. Operational- and construction readiness programmes are recommended to ensure that the Project can start in January 2019, as a delay in the start date could mean that the price peak opportunity could be missed.

The ability to fund National Infrastructure “off the balance sheet” is also important, as the inclusion thereof will increase the funding requirements by USD197m. Early and active stakeholder engagement initiatives are recommended to increase the likelihood that these costs can be funded externally.

Lastly, it is recommended that the feasibility study explore offtake agreements and property development contracts in more detail.

## 26.9 Operating Cost

It is recommended that actual budget quotations from mining contractors be sourced during the DFS to increase the confidence in the mining operating cost calculated in the PFS.

## 26.10 Capital Cost

The following work streams should be conducted in the project DFS, which will provide further certainty and improve the overall project accuracy,

- Detailed procurement process including all procurement and construction packages.
- Sufficient time needs to be allocated to the sourcing of pricing from the market.



## 27 References

- HAINES, A. and TERBRUGGE P.J. (1991) Preliminary estimation of rock slope stability using rockmass classification systems. Proceedings of the 7<sup>th</sup> International Congress. International Society of Rock Mechanics. Aachen. Balkema, Rotterdam. 2, 887-892.
- LAUBSCHER, D. H. (1990). A geomechanics classification system for the rating of rockmass in mine design. Journal of South African Institute of Mining and Metallurgy. 90, 257-273.
- LILLY, P.A. (1986). An empirical method of assessing rockmass blast-ability. The Australian IMM. Large Open-pit Mining Conference. Newman Combine Group, October 1986, 89-92.
- SRK (2017) NI 43-101 Technical Report, Updated Resource Estimate, Yandera Copper Project, Papua New Guinea, for Era Inc, by SRK Consulting (US) Inc, Effective Date December 15, 2016, Report Date February 1, 2017,. 139p.
- READ, J. and P. STACEY (2009) Guidelines for open pit slope design. CSIRO Publishing, Canberra.
- "Pre-feasibility Study Report, Ore Slurry Pipeline System, BBL010.9-B-DC001", prepared by BRASS (Beijing) Pipeline Technologies, Ltd, dated Sept 8, 2017.
- "Pre-feasibility study Report, Deep Sea Tailings Placement System, BBL010.9-B-DC002", prepared by BRASS (Beijing) Pipeline Technologies, Ltd, dated Sept 8, 2017.
- 3D Environmental. 2012. Terrestrial Vegetation, Fauna Study and Environmental Impact Assessment. Yandera Copper–Molybdenum–Gold Project. August. Prepared by 3D Environmental Pty Ltd in association with Natural Resource Assessments Pty Ltd and Common Scents Wildlife Tracking Pty Ltd for Coffey Environments and Era Mining Pty Ltd.
- ANZECC/ARMCANZ. 2000. Australian and New Zealand Guidelines for Fresh and Marine Water Quality. Chapter 3: Aquatic Ecosystems: Water Quality Guidelines for Toxicants. Prepared by Australian and New Zealand Environment and Conservation Council and Agriculture and Resource Management Council of Australia and New Zealand, Canberra, ACT.
- CAO. 2008. Advisory note: A guide to designing and implementing grievance mechanisms for development projects. A WWW publication accessed on 6 September 2017 at <http://www.cao-ombudsman.org/howwework/advisor/documents/implemgrieveng.pdf>. Compliance Advisor/Ombudsman, Washington DC USA.
- Coffey. 2010. Yandera Copper-Molybdenum-Gold Project. Single Beam Bathymetric Survey Report. July. Prepared by Coffey Environments Australia Pty Ltd.
- Coffey. 2012a. Yandera Copper-Molybdenum-Gold Project. Data Review Report. May. Prepared by Coffey Environments Australia Pty Ltd for Era Mining.
- Coffey. 2012b. Yandera Copper-Molybdenum-Gold Project EIS. Deep Sea Sediment Sampling Survey Report. June. Prepared by Coffey Environments Australia Pty Ltd for Era Mining.
- Conton, L. 1996. Usino. Pages 360-363. In Hays, T. E. (ed.), Encyclopaedia of World Cultures. Volume 2: Oceania. Boston, USA.
- DEC. 2004a. Guideline for conduct of environmental impact assessment and preparation of environmental impact statement. Department of Environment and Conservation, Papua New Guinea.



- DEC. 2004b. Social impact assessment guideline. Draft. Department of Environment and Conservation, Port Moresby.
- DOR. 2007. Security Calculation Procedure – Advisory Note AA7-013. Northern Territory Government Department of Resources. November 2007.
- DOR. 2009. Security Calculation Spreadsheet – AF7-010. Northern Territory Government Department of Resources. 1 September 2009.
- EGi. 2011. Yandera Copper-Molybdenum-Gold Project. Column Leach Testing of Composite Waste Rock Samples – 18 Month Progress Report. June. Prepared by Environmental Geochemistry International Pty Ltd for Coffey Environments Pty Ltd.
- EGi. 2013. Yandera Copper-Molybdenum-Gold Project. Column Leach Testing of a Laboratory Prepared Tailings Sample. February. Prepared by Environmental Geochemistry International Pty Ltd for Coffey Environments Pty Ltd.
- EPFI. 2013. Equator Principles Financial Institutions. The “Equator Principles”: A financial industry benchmark for determining, assessing and managing social and environmental risk in project financing. June. A WWW publication accessed on 12 September 2017 at: [http://www.equator-principles.com/resources/equator\\_principles\\_III.pdf](http://www.equator-principles.com/resources/equator_principles_III.pdf)
- GHD. 2012. Yandera Copper-Molybdenum-Gold Project EIS. Aquatic Biodiversity Study. Final Report. August. Prepared by GHD for Coffey Environments Australia Pty Ltd.
- Hammermaster, E. T., Saunders, J. C. 1995. Forest resources and vegetation mapping of Papua New Guinea. Canberra, Australia.
- IAIA. 2003. International principles for social impact assessment. International Association for Impact Assessment. Impact Assessment and Project Appraisal, volume 21, number 1, March 2003, pages 5–11, Beech Tree Publishing, 10 Watford Close, Guildford, Surrey GU1 2EP, UK. A WWW publication accessed 6 September 2017 at <https://www.iaia.org/uploads/pdf/IAIA-SIA-International-Principles.pdf>.
- IFC. 2003. Good practice note: addressing the social dimensions of private sector projects. International Finance Corporation World Bank Group. Washington, D.C. A WWW publication accessed on 6 September 2017 at [http://www.ifc.org/wps/wcm/connect/topics\\_ext\\_content/ifc\\_external\\_corporate\\_site/sustainability-at-ifc/publications/publications\\_gpn\\_socialdimensions\\_wci\\_1319578072859](http://www.ifc.org/wps/wcm/connect/topics_ext_content/ifc_external_corporate_site/sustainability-at-ifc/publications/publications_gpn_socialdimensions_wci_1319578072859).
- IFC. 2007a. Stakeholder engagement: a good practice handbook for companies doing business in emerging markets. A WWW publication accessed on 6 September 2017 at [http://www.ifc.org/wps/wcm/connect/938f1a0048855805beacfe6a6515bb18/IFC\\_StakeholderEngagement.pdf?MOD=AJPERES](http://www.ifc.org/wps/wcm/connect/938f1a0048855805beacfe6a6515bb18/IFC_StakeholderEngagement.pdf?MOD=AJPERES).
- IFC. 2007b. International Finance Corporation. Environmental, Health, and Safety General Guidelines. April. A WWW publication accessed on 12 September 2017 at: <http://www.ifc.org/wps/wcm/connect/554e8d80488658e4b76af76a6515bb18/Final%2B-%2BGeneral%2BEHS%2BGuidelines.pdf?MOD=AJPERES>
- IFC. 2007c. International Finance Corporation. Environmental, Health and Safety Guidelines for Mining. December. A WWW publication accessed on 12 September 2017 at: <http://www.ifc.org/wps/wcm/connect/1f4dc28048855af4879cd76a6515bb18/Final++Mining.pdf?MOD=AJPERES>
- IFC. 2012. Performance standards on social and environmental sustainability. International Finance Corporation, Washington, DC.



- Independent State of Papua New Guinea. 2010. Papua New Guinea's Fourth National Report to the Convention on Biological Diversity.
- Löffler, E. 1977. Geomorphology of Papua New Guinea. CSIRO in association with Australian National University Press, Canberra, Australia.
- McAlpine, J. R., Keig, G., & Falls, R. 1983. Climate of Papua New Guinea. The Australian National University, Canberra Australia.
- Pacific Climate Change Science Program partners. 2011. Current and future climate of Papua New Guinea. A WWW publication accessed on 15 September 2017 at: [http://www.pacificclimatechangescience.org/wp-content/uploads/2013/06/14\\_PCCSP\\_PNG\\_8pp.pdf](http://www.pacificclimatechangescience.org/wp-content/uploads/2013/06/14_PCCSP_PNG_8pp.pdf).
- Simpson et al. (2013). Revision of the ANZECC/ARMCANZ Sediment Quality Guidelines. Simpson, S.L., Batley, G.E., Chariton, A.A. CSIRO Land and Water Science Report 08/07. May 2014. Prepared for the Department of Sustainability, Environment, Water, Population and Communities.
- SLR. 2012. Environmental Impact Assessment Air Quality and Greenhouse Gas Impact Assessment Yandera Copper-Molybdenum-Gold Project. September. Prepared by SLR Consulting Australia Pty Ltd for Coffey Environments Australia Pty Ltd.
- World Bank. 2008. Pacific Catastrophe Risk Financing Initiative Country Risk Profile Papua New Guinea. A WWW publication accessed on 15 September 2017 at: [http://siteresources.worldbank.org/INTEAPREGTOPRURDEV/Resources/PCRFdraftBrochure\\_PNG\\_September2008.pdf](http://siteresources.worldbank.org/INTEAPREGTOPRURDEV/Resources/PCRFdraftBrochure_PNG_September2008.pdf).
- Zimmer-Tamakoshi, L. 2008. 2007 Yandera survey / census. Report prepared for Era Mining Ltd, Perth, Australia.
- Zimmer-Tamakoshi, L. 2009. 2007 Yandera and 2008 Gegeru and Karizoko survey/censuses. Report prepared for Era Mining Ltd, Perth, Australia.
- Zimmer-Tamakoshi. 2010. 2010 Banu-Imbrum Hydro-Rai Coast Survey Census. May. Prepared by Zimmer-Tamakoshi, L., for Era Mining Limited.
- Advisian, 2017a. Yandera Project Pre-Feasibility Study – Climate and Hydrology
- Advisian, 2017b. Yandera Project Pre-Feasibility Study – Preliminary Water Balance
- Advisian, 2017c. Yandera Project Pre-Feasibility Study – Hydrogeological Conceptualisation and Open Pit Water Management.
- Keane Associates Ltd. (2016): Yandera Cu-Mo-Au Project – Report on Hydrology Site Visit, 19-23 September 2016
- BME, 2016. Blasting Guide for Surface Mining. Source: <http://www.bme.co.za/resources/brochures/category/2-brochures> (accessed 17 July 2017)
- Yandera Ore Characterisation and Flotation Testwork for Marengo Mining, AMDEL MINERAL LABORATORIES, Project No 2504, July 2007
- Metallurgical Testwork Conducted Upon Samples of Copper Drill Core from the Yandera Copper Project for Marengo Mining (PNG) Limited, ALS-AMMTEC. Report No 11129, June 2008.
- Drop weight and SMC Test Report on Twenty Five Samples From Yandera Cu-Mo Project, JKTech.Pty Ltd, Job No 08001, June and November 2008.





- Yandera Cu-Mo Project, Metallurgical Testwork Report, GRD Minproc Limited, Report No 600010-000021-002-005, June 2009.
- Metallurgical Testwork Conducted Upon Yandera Cu/Mo Ore for Marengo Mining Limited, ALS-AMMTEC . Report No 12188, October 2010.
- Metallurgical Testwork Conducted Upon Samples of Ore from the Yandera Copper /Molybdenite Project for Marengo Mining Limited/GRD MINPROC LTD, ALS-AMMTEC . Report No 12188, January 2011
- Flotation Testwork Conducted upon Yandera Copper/Molybdenite Samples of Ore Marengo Mining (PNG) Limited, ALS-AMMTEC . Report No 11545, January 2011
- Test Report on Mineral Processing of Yandera Cu & Mo Ore, BGRIMM report Cy201119690000001, April 2012
- Verification Test Report on Mineral Processing of Four Samples Yandera Cu & Mo Ore, BGRIMM report ky201220560000001, April 2012
- Yandera SAC and SABC Assessment for Arccon (WA) Pty Ltd, Orway Mineral Consultants, Report No 8887.3 rev B, June 2012
- Thickening Testwork on Yandera Final Copper Concentrate , Outotec (Australasia), Report No. S11738
- Thickening Testwork on Yandera Final Copper Tailings, Outotec (Australasia), Report No. S1173TA
- Filtration Testwork on Yandera Final Copper Concentrate , Outotec (Australasia), Report No. 102059.
- Transportable Moisture Limit, Angle of Repose. Moisture Content and Bulk Density, Microanalysis Australia Pty Ltd, October 2012
- A13914 Yandera Project Locked Cycle Report Conducted Upon Yandera Samples for Marengo Mining, ALS-AMMTEC . Report No 13914, February 2013.
- Flotation Testwork Conducted upon Yandera Copper/Molybdenite Samples of Ore Marengo Mining (PNG) Limited, ALS – AMMTEC . Report No 13914, January 2013.
- Section 5:-Metallurgical Processing: - 30 MTPA Feasibility Study Report, Arcon, 2013.



## 28 Glossary

---

- Dendritic submarine canyons – a canyon system having a branching structure similar to the branching of a tree, with numerous smaller canyons branching into main canyons
- Graben – a depression of the earths' crust bounded by geological fault lines on either side



## 29 Date and Signature Page

### 29.1 Certificate of Qualified Person – T. le Roux

I, Tertius le Roux, do hereby certify that:

- a) I am a Principal Consultant, Mining Engineering at WorleyParsons (Pty) Ltd trading as Advisian, 39 Melrose Boulevard, Melrose Arch, Johannesburg, 2076, South Africa.
- b) This certificate applies to the report titled: Independent Technical Report on the Yandera Project Pre-feasibility Study – Project Areas located on the southwestern portion of the Province of Madang in Papua New Guinea for ERA Resources Inc. with effective date 27 November 2017.
- c) I graduated with a Master’s Degree, Magister in Mineral Resource Management from the University of the Free State in 2005 and a B Degree, Baccalareus Technologiae Mining Engineering from the University of Johannesburg in 2008. In addition, I obtained a National Diploma in Coal Mining and a National Higher Diploma in Mining from the Technikon Witwatersrand in 1994 and 1995 respectively. In 1996 I was awarded a Mine Managers Certificate from the Department of Mineral and Energy Affairs.

I have worked in the mining industry for more than 25 years, specialising in mine design, mine planning, strategic scenario testing, mineral reserve estimation and management of technical personnel across the entire mining value including at executive level. I have extensive open pit hard rock experience. Operational exposure includes polymetallic mining (Ni/Cu as main commodity) and other multi-pit operations in iron ore and coal. I have worked as consultant on multiple PFS and DFS studies for various commodities, including disseminated sulphide ore bodies, using approaches described by the Canadian Code for reporting of Resources and Reserves – National Instrument 43-101 (Standards of Disclosure for Mineral Projects).

I am a member/fellow of the following professional associations, which meet all the attributes of a Professional Association or a Self-Regulatory Professional Association, as applicable (as those terms are defined in NI 43-101):

Class	Professional Society	Year of Registration
Fellow	Southern African Institute of Mining and Metallurgy. FSAIMM - 704147	2017

I am a qualified person for the purposes of NI43-101.

- d) I inspected the property during a 5-day period from 23<sup>rd</sup> to 28<sup>th</sup> July 2017 as part of the QP’s Site Visit to the Yandera Project footprint area to gain insight into the pit locations, environmental, social, topo-graphical, logistical and general conditions. Visual inspection was conducted of the proposed mining and milling precinct and Waste Rock Dump locations as well as an on foot excursion to various drill sites, the Gremi pit area and Dengru River.
- e) I am jointly-responsible for Sections 1, 2, 3, 18, 19, 21, 22 24, 25, 26 and 27 of the Qualified Person’s Report titled the Independent Technical Report on the Yandera Project Pre-feasibility Study Project - Areas located on the Southwestern Portion of the Province of Madang in Papua New Guinea for ERA Resources Inc.; the effective date of Mineral Resources and Reserves of this report is 27 November 2017.



I am responsible for Sections 5, 15, 16 and 20 of the Qualified Person's Report titled the Independent Technical Report on the Yandera Project Pre-feasibility Study Project - Areas located on the Southwestern Portion of the Province of Madang in Papua New Guinea for ERA Resources Inc.; the effective date of Mineral Resources and Reserves of this report is 27 November 2017

- f) I am independent from the issuer as described in section 1.5 of the National Instrument NI43-101 Standards of Disclosure for Mineral Projects.
- g) I have had no prior involvement in the property that is the subject of the technical report.
- h) I have read the definition of "Qualified Person" set out in the Canadian Code for reporting of Resources and Reserves – National Instrument 43-101 (Standards of Disclosure for Mineral Projects), Form 43-101F1 and the Companion Policy Document 43-101CP ("NI 43-101") and certify that by reason of my education, affiliation with professional associations and past relevant work experience, I fulfil the requirements to be a Qualified Person for the purposes of this Qualified Persons' Report.

I have read the NI 43-101 and this Report has been prepared in compliance with it.

- i) As of the effective date, to the best of my knowledge, information and belief, the Report contains all scientific and technical information required to be disclosed to make the Report not misleading. The facts presented in the Report are, to the best of my knowledge, correct.

Yours faithfully,

**T. LE ROUX**  
Pr. Tech Eng, FSIAMM, SACMA



## 29.2 Certificate of Qualified Person – M. Dworzanowski

I, Marek Dworzanowski, do hereby certify that:

- a) I am an Extended Consultant in the branch of Metallurgical Engineering at WorleyParsons (Pty) Ltd trading as Advisian, 39 Melrose Boulevard, Melrose Arch, Johannesburg, 2076, South Africa.
- b) This certificate applies to the report titled: Independent Technical Report on the Yandera Project Pre-feasibility Study – Project Areas located on the southwestern portion of the Province of Madang in Papua New Guinea for ERA Resources Inc. with effective date 27 November 2017.
- c) I graduated with a BSc Honours in Mineral Processing from the University of Leeds, United Kingdom, in July 1980. In March 2016, I was appointed as a Visiting Adjunct Professor in Metallurgical Engineering at the School of Chemical & Metallurgical Engineering, University of the Witwatersrand, South Africa.

I have over 37 years' experience in the mining industry, during which time I gained a considerable amount of diverse experience in various roles within the areas of production, project execution, project studies, technical consulting and research & development. My commodity experience covers Diamonds, Gold, Iron Ore, Platinum Group Metals, Copper, Coal, Copper/Cobalt, Nickel, Chromium, Mineral Sands, Niobium, Phosphate, Zinc, Tin, Vanadium, Manganese, Lithium. I have worked in the following countries: South Africa, Australia, Botswana, Namibia, Zimbabwe, Zambia, Ghana, Chile and Brazil. My experience gained in various roles, unit processes and commodities result in a unique skills set, including multidisciplinary due diligence studies, corporate governance, technical and project optimisation reviews.

I am a member/fellow of the following professional associations, which meet all the attributes of a Professional Association or a Self-Regulatory Professional Association, as applicable (as those terms are defined in NI 43-101):

Class	Professional Society	Year of Registration
Fellow	Southern African Institute of Mining and Metallurgy. FSAIMM 19594	2006
Pr.Eng	Engineering Council of South Africa (ECSA) – 870480	1987

I am a qualified person for the purposes of NI43-101

- d) I am co-responsible for Sections 1, 2, 3, 18, 21, 24, 25, 26 and 27 of the Qualified Person's Report titled the Independent Technical Report on the Yandera Project Pre-feasibility Study Project - Areas located on the Southwestern Portion of the Province of Madang in Papua New Guinea for ERA Resources Inc. I am responsible for Sections 13 and 17.
- e) I am independent from the issuer as described in section 1.5 of the National Instrument NI43-101 Standards of Disclosure for Mineral Projects.
- f) I have had no prior involvement in the property that is the subject of the technical report.



- g) I have read the definition of “Qualified Person” set out in the Canadian Code for reporting of Resources and Reserves – National Instrument 43-101 (Standards of Disclosure for Mineral Projects), Form 43-101F1 and the Companion Policy Document 43-101CP (“NI 43-101”) and certify that by reason of my education, affiliation with professional associations and past relevant work experience, I fulfil the requirements to be a Qualified Person for the purposes of this Qualified Persons’ Report.

I have read the NI 43-101 and this Report has been prepared in compliance with it.

- h) As of the effective date, to the best of my knowledge, information and belief, the Report contains all scientific and technical information required to be disclosed to make the Report not misleading. The facts presented in the Report are, to the best of my knowledge, correct.

Yours faithfully,

**M. DWORZANOWSKI**  
B.Sc Hons, Pr.Eng, FSAIMM



## 29.3 Certificate of Qualified Person – J.B. Pennington



SRK Consulting (U.S.), Inc.  
5250 Neil Road, Suite 300  
Reno, NV 89502

T: (775) 828-6800  
F: (775) 828-6820  
reno@srk.com  
www.srk.com

### Certificate of Qualified Person – J.B. Pennington

I, Jay Pennington, do hereby certify that:

- a) I am a Resource Geologist and Practice Leader with SRK Consulting (U.S.), Inc. based in 5250 Neil Road, Reno, Nevada, USA.
- b) This certificate applies to the report titled: Independent Technical Report on the Yandera Project Pre-feasibility Study – Project Areas located on the southwestern portion of the Province of Madang in Papua New Guinea for ERA Resources Inc. with effective date 27 November 2017.
- c) I graduated with a Bachelor of Science degree from Tulane University in New Orleans, LA, U.S.A. in May, 1985 and a Master of Science in Geology Tulane University in New Orleans, LA, U.S.A. in May 1987.

I have worked as a practicing professional geologist for over 31 with my specialisation lying within geologic and resource modelling. I have completed a number of Mineral Resource estimations various commodities, including copper, molybdenum, gold and silver, using approaches described by the Canadian Code for reporting of Resources and Reserves – National Instrument 43-101 (Standards of Disclosure for Mineral Projects)).

I am a Certified Professional Geologist, C.P.G. #11245, which meets all the attributes of a Professional Association or a Self-Regulatory Professional Association, as applicable (as those terms are defined in NI43-101):

Class	Professional Society	Year of Registration
Member	American Institute of Professional Geologist C.P.G. #11245	2009

I am a qualified person for the purposes of NI43-101.

- d) I am responsible for Sections 6 to 12, 14 and portions of Sections 1, 2, 3, 4, 23, 24 25, 26 and 27 and the Qualified Person's Report titled the Independent Technical Report on the Yandera Project Pre-feasibility Study Project - Areas located on the Southwestern Portion of the Province of Madang in Papua New Guinea for ERA Resources Inc.

**U.S. Offices:**

Anchorage 907.677.3520  
Denver 303.985.1333  
Elko 775.753.4151  
Fort Collins 970.407.8302  
Reno 775.828.6800  
Tucson 520.544.3688

**Canadian Offices:**

Saskatoon 306.955.4778  
Sudbury 705.682.3270  
Toronto 416.601.1445  
Vancouver 604.681.4196  
Yellowknife 867.873.8670

**Group Offices:**

Africa  
Asia  
Australia  
Europe  
North America  
South America





- e) I have read the definition of "Qualified Person" set out in the Canadian Code for reporting of Resources and Reserves – National Instrument 43-101 (Standards of Disclosure for Mineral Projects), Form 43-101F1 and the Companion Policy Document 43-101CP ("NI 43-101") and certify that by reason of my education, affiliation with professional associations and past relevant work experience, I fulfil the requirements to be a Qualified Person for the purposes of this Qualified Persons' Report.

I have read the NI 43-101 and this Report has been prepared in compliance with it.

- f) As of the effective date, to the best of my knowledge, information and belief, the Report contains all scientific and technical information required to be disclosed to make the Report not misleading.
- g) The facts presented in the Report are, to the best of my knowledge, correct.
- h) The analyses and conclusions presented in the Report are limited only by the reported forecasts and conditions.
- i) I have no present or prospective interest in the subject property or asset. I have no bias with respect to the assets that are the subject of the Report, or to the parties involved with the assignment.
- j) I have read this technical Report and NI43-101 Standards of Disclosure for Mineral Projects and this Report has been prepared in compliance with NI43-101.
- k) My compensation, employment or contractual relationship with the Commissioning Entity is not contingent on any aspect of the Report.
- l) I carried out a personal inspection of the property from November 10-14, 2014.
- m) I have had no prior involvement with the property that is the subject of this Report.

Yours faithfully,

**J.B. PENNINGTON, M.Sc. C.P.G. #11245**



## 29.4 Certificate of Qualified Valuator – C. Fraser

I, Cobus Fraser, do hereby certify that:

- I am a “Director – Valuation and Optimisation” of Fraser McGill (Pty) Ltd, The Pivot, Block E, 1 Montecasino Boulevard, Fourways, Johannesburg, 2191, South Africa.
- This certificate applies to the report titled: Independent Technical Report on the Yandera Project Pre-feasibility Study - Project Areas located on the Southwestern Portion of the Province of Madang in Papua New Guinea for ERA Resources Inc. The effective date of the report is 27 November 2017 and the valuation date is 1 January 2019.
- I hold the following qualifications:
  - Chartered Accountant – CA(SA)
  - Master’s in Business Administration, Stellenbosch Business School, 2017
  - BCom (Hons) Accounting, University of Pretoria, 2008
  - Certificate in the Theory of Accountancy, University of Pretoria, 2008
  - BCom Accounting, University of Pretoria, 2007
- I have performed valuation and optimisation work in the mining industry for more than 7 years. Other functional experience includes corporate strategy; due diligence studies; capital efficiency reviews; portfolio optimisation; business case modelling; operations improvement; and value driver analysis.
- I am a member of the following professional associations, which meet all the attributes of a Self-Regulatory Professional Association, as applicable (as those terms are defined in CIMVAL):

Class	Professional Society	Year of Registration
Member	South African Institute of Chartered Accountants, Membership No. 20003762	2011

- I am responsible for Sections 19 and 22 of the Qualified Person’s Report titled the Independent Technical Report on the Yandera Project Pre-feasibility Study Project - Areas located on the Southwestern Portion of the Province of Madang in Papua New Guinea for ERA Resources Inc; The effective date of the report is 27 November 2017 and the valuation date is 1 January 2019.
- I am independent from the issuer as described in section 1.5 of the National Instrument NI 43-101 Standards of Disclosure for Mineral Projects.
- I have had no prior involvement in the property that is the subject of the technical report, apart from independent professional consulting services which were provided to the client.
- I am a Qualified Valuator as the terms are defined in CIMVAL for the purpose of the valuation.



I have read the NI 43-101 and this Report has been prepared in compliance with it.

- As of the effective date, to the best of my knowledge, information and belief, the Report contains all scientific and technical information required to be disclosed to make the Report not misleading. The facts presented in the Report are, to the best of my knowledge, correct.
- I have no present or prospective interest in the subject property or asset and have no bias with respect to the assets that are the subject of the Report, or to the parties involved with the assignment.
- My compensation and contractual relationship with the Commissioning Entity is not contingent on any aspect of the Report.
- I did not undertake a personal inspection of the property.

Yours faithfully,

C. FRASER  
Chartered Accountant - CA(SA)



## 29.5 Certificate of Qualified Person – D.H. Sepulveda



### CERTIFICATE OF QUALIFIED PERSON

- I, Daniel H. Sepulveda, B.Sc., SME-RM, do hereby certify that:
1. I am Associate Consultant (Metallurgy) of SRK Consulting (U.S.) Inc., 1125 Seventeenth Street, Suite 600, Denver, CO, USA, 80202.
  2. This certificate applies to the technical report titled "Independent Technical Report on the Yandera Project Pre-feasibility Study" with an Effective Date 27 November 2017 (the "Technical Report").
  3. I graduated with a degree in Extractive Metallurgy from University of Chile in 1992. I am a registered member of the Society of Mining, Metallurgy, and Exploration, Inc. (SME), member No 4206787RM. I have worked as a Metallurgist for a total of 25 years since my graduation from university. My relevant experience includes: employee of several mining companies, engineering & construction companies, and as a consulting engineer.
  4. I have read the definition of "qualified person" set out in National Instrument 43-101 (NI 43-101) and certify that by reason of my education, affiliation with a professional association (as defined in NI 43-101) and past relevant work experience, I fulfill the requirements to be a "qualified person" for the purposes of NI 43-101.
  5. I have not visited the Yandera Copper Project property.
  6. I am responsible for copper recovery estimate for the oxide mineralization in Section 13 of this Technical Report.
  7. I am independent of the issuer applying all the tests in section 1.5 of NI 43-101.
  8. I have not had prior involvement with the property that is the subject of the Technical Report.
  9. I have read NI 43-101 and Form 43-101F1 and the sections of the Technical Report I am responsible for have been prepared in compliance with that instrument and form.
  10. As of the aforementioned Effective Date, to the best of my knowledge, information and belief, the sections of the Technical Report I am responsible for contains all scientific and technical information that is required to be disclosed to make the Technical Report not misleading.

Yours faithfully,

Daniel H. Sepulveda, B.Sc. SME-RM

**SME**

Society for  
Mining, Metallurgy  
& Exploration

Daniel Sepulveda  
SME Registered Member No. 4206787RM

Signature:   
Date Signed: 2017/11/27  
Expiration Date: \_\_\_\_\_

#### U.S. Offices:

Anchorage: 907 877 8500  
Cleveland: 550 452 0162  
Denver: 303 885 1393  
El Paso: 778 759 4151  
Fort Collins: 970 407 8202  
Houston: 778 638 6501  
Tucson: 520 344 3860

#### Canadian Offices:

Calcutta: 088 855 4775  
Edmonton: 780 019 0910  
Toronto: 416 001 0445  
Vancouver: 604 881 4106  
Yellowknife: 867 875 8870

#### Group Offices:

Africa  
Asia  
Australia  
Brazil  
North America  
South America



**Advisian**

WorleyParsons Group

Era Resources Inc.  
C00651-0000-PM-REP-0005  
Yandera – NI 43-101 Technical Report



---

# Appendix A: SRK Yandera Oxide Recovery Estimate

---



## Technical Memorandum

---

<b>To:</b>	Nate Chutas	<b>Date:</b>	25 October, 2017
<b>Company:</b>	Era Resources	<b>From:</b>	Daniel Sepulveda
<b>Copy to:</b>	Andre Wessels	<b>Reviewed by:</b>	J. Pennington
<b>Subject:</b>	Review of Metallurgical Test Work of Yandera Copper Oxide	<b>Project #:</b>	465300.060

---

### 1. Summary and Recommendations

SRK was requested to review the metallurgical work plan and data collected to date supporting the flotation of copper oxide material from the Yandera Copper Project in Papua New Guinea. Era Resources asked SKR to provide an opinion on the potential metallurgical recoveries achievable at industrial scale to support the completion of a prefeasibility (PFS) level study being completed on the project.

No formal reports were available from any of the three companies involved. The information available to SRK consisted of raw spreadsheets with results as follows:

- A metallurgical flotation testing program executed in 2017 September that was directed by Advisian, an engineering group in South Africa, and executed by McClelland Laboratories, a commercial metallurgical testing facility in Nevada, U.S.A., and
- A mineralogical analysis (QEMSCAN) performed on the tested samples executed in early 2017 October by Bureau Veritas laboratory located in Richmond, British Columbia, Canada.

SRK concluded that the flotation metallurgical testing program consisting of a total of 8 flotation tests using 6 samples sourced from distinctive diamond drill holes in the Gremi deposit area was all material modeled as copper oxide from the known resource. This metallurgical testing program was extremely limited in scope as it trialed a narrow range of reagent additions keeping mostly all other key parameters constant. Unfortunately, but not surprising given the narrow range of tested parameters and the higher complexity of floating mixed ore when compared to sulfides only, the flotation tests reached copper recoveries ranging from 27% to 53%, which are relatively low recoveries utilizing flotation.

It is SRK experience that the flotation of oxide minerals is a relatively common practice in every new copper deposit where the mineralized rock close to surface has been heavily weathered. The presence of oxide and sulfide minerals in varying relative proportion along with the major presence of clay minerals typically translates to industrial scale in copper recoveries lower than the 90% target. In practice, typical copper recoveries using flotation on copper oxide material range from 50% up to 70%

and incur a higher reagent cost. The sizing of the flotation stage (residence time) is another key element normally ignored in the engineering phase that sets an upper limit to the ability of industrial operations to achieve higher copper recovery.

SRK recommends that at this prefeasibility level Era Resources use a conservative value of 55% recovery for the oxide material, and strongly suggest initiating a metallurgical testing program that will support or further improve that recovery figure.

SRK recommends a testing program that includes all the fundamental variables: P80, solids concentration, pH, rpm, residence time, redox, multiple reagent options and dosing. SRK estimates that such a program will total approximately 60 to 80 batch flotation tests plus three locked cycle tests. This metallurgical test work would likely take between three to four months to complete from the time that samples are made available to the laboratory and will cost approximately US\$150,000 to US\$200,000.

## 2. Metallurgical Testwork Program Review

The key results from the metallurgical testwork program are presented in Table 1. A total of six different diamond drill holes were tested individually, as well as master composite from all the DDHs. Key observations from the flotation test results are as follows:

- Rougher copper recovery ranged from 23% up to 53.1%.
- The achieved copper recovery is roughly directly proportional to the portion of copper associated to sulfide minerals, see Chart 1.
- Even though from the geological point of view it is representative of the oxide zone, the mineralogical analysis determined that the samples tested have a varying range of Cu oxide/Cu sulfide ratio.
- The information available suggest that gold is associated with the copper sulfides, see Chart 3. The association of gold (a credit metal for the concentrates) needs to be understood before attempting to maximize its deportment to the final concentrate stream.
- Rougher concentrate copper grades were extremely low, they ranged from 0.77% up to 1.60%, mostly because of the large mass pulls, see Chart 2. It is highly probable that the liberation size is significantly finer than  $P_{80} = 150 \mu\text{m}$  used for 6 of the tests, and  $P_{80} = 75 \mu\text{m}$  size used in one test.
- The rougher concentrate recovery trend, though having slow kinetics (see Chart 2) still showed an upward trend. A combination of grind size, residence time, and favorable physicochemical conditions have the potential to improve kinetics and overall ultimate copper recovery.
- The copper grade in oxide concentrates is typically much lower than that of sulfide concentrates

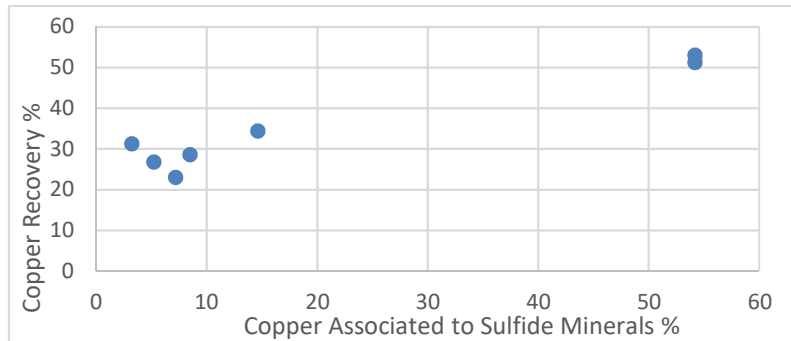


**Table 1: Yandera – Oxide Flotation Testwork Results**

Composite	Head Grade Copper%		Flotation Feed Size	Rougher Concentrate, Cu grade%	Rougher Tails, Cu grade%	Rougher Copper Recovery %	Rougher Gold Recovery %	Mineralogy Analysis Copper associated to Sulfide minerals
	Calculated	Assayed	80% -(mm)					
<b>YD346</b>	0.36	0.35	150	0.77	0.30	26.8	16.3	5.2
<b>YD252</b>	0.26	0.25	150	0.62	0.22	23.0	64.9	7.2
<b>YD356</b>	0.32	0.31	150	1.60	0.17	51.3	54.0	54.2
<b>YD517</b>	0.47	0.46	150	1.19	0.35	34.4	48.0	14.6
<b>YD139</b>	0.49	0.47	150	1.35	0.39	28.6	20.0	8.5
<b>YD140</b>	0.46	0.45	150	1.01	0.37	31.3	25.1	3.2
<b>YD356</b>	0.32	0.31	75	1.02	0.18	53.1	n.a.	54.2
<b>Master</b>	0.38	0.39	150	1.11	0.29	31.7	n.a.	n.a.

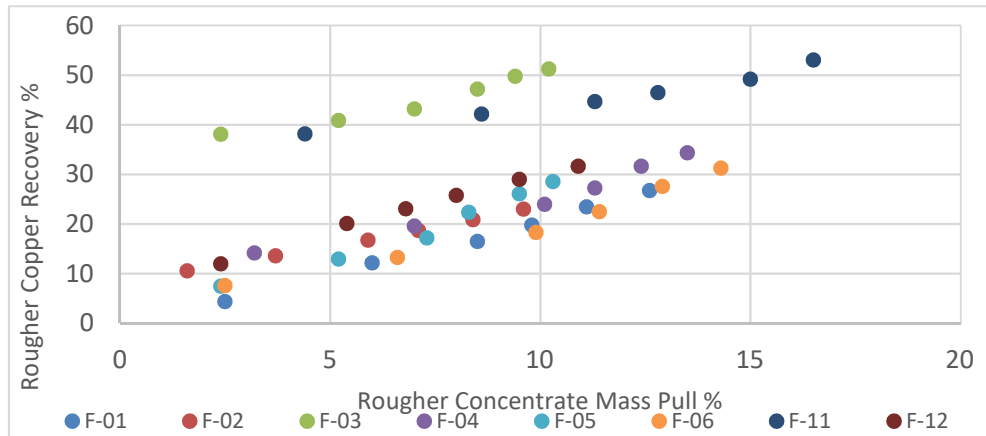
Source: SRK, 2017

**Chart 1: Copper Recovery versus %Copper Associated to Sulfide Minerals**



Source: SRK, 2017

**Chart 2: Rougher Copper Recovery versus Concentrate Mass Pull**



### 3. Recommendations for Further Metallurgical Testing

The following is the outline of the metallurgical testing program necessary for the Yandera Project's oxide characterization:

- Currently, the laboratory has a total of approximately 260 kg from the previous testing campaign. A representative sample must be selected from the remaining material to be tested until a set of process conditions are defined. This will satisfy PFS requirements. Additional samples from the site will likely be required to complete variability testing for FS.
- An initial set of rougher flotation tests that will evaluate a range of particle sizes (at least 4 sizes), solids density, and a scale of sulfidation, collectors, and pH values. Total estimate of tests is approximately 30. All products to be assayed by sequential copper, Fe, Au, SG.
- Results from the above set will be further refined using a combination of batch rougher tests (approximately 20 tests) and rougher kinetic tests (approximately 10 tests). All products to be assayed by sequential copper, Fe, Au, SG.
- Results from above three bullets need to be confirmed at batch level, and then tested in a locked-cycle test, in at least duplicate. These tests should be the final confirmation of the metallurgical recovery results to be projected to industrial scale.

Developing the metallurgical process to achieve commercial oxide copper recovery is not as straightforward as a conventional sulfide material, and therefore requires a close, regular interaction between the owner and the testing laboratory. Technical and economic decisions will need to be made at every step of the testing program by the owner's representative in order to achieve the optimum metal recovery.

### 4. Recommendations for the Engineering Design Phase

Following are key recommendations and comments regarding the sizing of the concentrator unit when processing oxide and mixed ore. A suitable metallurgical testwork program should be used to confirm and/or correct them:

- Comminution: mixed ore is typically softer than pure sulfide material. Assuming the crushing and grinding stages were properly sized for sulfide ore, then the current equipment should be suitable to process oxide/mixed ore without any loss in throughput.
- The hydrocyclone classification stage (part of the grinding circuit) will need to be oversized to handle mixed ore. Alternatively, if the current design considers spare units, then the operation with mixed ore will likely make use of all the installed classification capacity. Adding hydrocyclone units to the current installation is likely marginal to negligible additional capex to the project.
- The flotation stage needs to consider the slower flotation kinetics from the mixed ore. At this prefeasibility level consider 45 minutes in the rougher-scavenger stage. Using 500 m<sup>3</sup> flotation cells instead of the current 330 m<sup>3</sup> will reduce the overall capex (building, foundation, etc.) and opex (maintenance) when compared to the current estimates.
- At least one flotation column stage in the last cleaning stage is recommended for the mixed ore (and the sulfide ore). This change should be considered as an improvement in the next phase of the project.

- Assuming the final tailings thickener was sized for sulfide ore, then it will likely be subject to upsets when processing mixed ore. Consider at least a 20% safety factor in terms of area. Consistently, the tailings flocculant plant needs to be able to operate at double the normal flocculant addition rate.
- The operating cost, particularly the reagent consumption for the oxide (mixed) ore appears reasonable at this stage.
- Under the current flowsheet design, gold recovery should be estimated at 35%.

## 5. Benchmarking

A benchmarking of copper concentration projects is provided in Table 2. Most of the projects correspond to actual industrial operations that, in their early operating years, processed a variable proportion of oxides, others correspond to metallurgical testing programs.

Some of the industrial concentration plants were designed for sulfides only, but because of economics, once operation started, it was decided to blend in oxides/mixed ore with limited results. Others had flotation circuits dedicated to process oxide and mixed material and achieved significantly higher recoveries (OP-01, OP-02, OP-04, OP-05, and OP-09). The enhanced level of performance achieved by those projects could be achieved by Yandera if the process plant is designed and sized taking in consideration the specific additional requirements of the mixed ore, as described previously in Section 4.0.

**Table 2: Benchmark – Oxide Flotation Projects**

Location	Operation	Operation type	Ore type	Copper Mineralogy	Clay presence	Head Grade, %CuT	Head Grade, %Cu Oxide	Head Grade, %Cu Native	P <sub>80</sub>	Flowsheet	Comments	pH	Oxides Recovery %Cu
Peru	OP-01	Industrial	Complex mixed ore	a) Oxides: Tenorite, Cuprite, Chrysocolla, Neotacite, Malacite, Azurite. b) Native Copper c) Sulfides: Chalcopyrite, Chalcocite, Covellite, Bornite	yes	1.37	0.45	0.35	37% +150#	Flotation	multiple, sequential collectors	8.7	55%
Chile	OP-02	Industrial	Mixed ore	a) Oxides: Atacamite y Chrysocolla c) Sulfides: Chalcocite, Bornite, Chalcopyrite, Covellite	yes	1.15	0.25		50% - 74 μm	Convencional flotation, Oxides Sulfidation, Acid Flotation	multiple, sequential collectors + NaSH		50% - 70%
Chile	OP-03	Industrial	Mixed ore	a) Oxides: Atacamite, Chrysocolla, Malacite, Azurite, c) Sulfides: Bornite, Chalcocite, Covellite, Pyrite	yes					Flotation	multiple, sequential collectors + NaSH. Plant was not designed for oxides. Feed Blending	<9.5	marginal 2%
Chile	OP-04	Industrial, Laboratory	Mixed ore	a) Oxides: Atacamite, Chrysocolla, Malacite, Azurite, c) Sulfides: Chalcopyrite, Chalcocite, Covellite, Pyrite	yes	0.95	0.04		27% +100#	Convencional flotation, Oxides Sulfidation	multiple, sequential collectors	LA: 9 Flot. 8	80%
Peru	OP-05	Laboratory	Oxide	a) Oxides: Malacite / Azurite	yes					Flotation	multiple, sequential collectors + NaSH, Na <sub>2</sub> S	11	>80%
Peru	OP-06	Laboratory	Oxide	a) Oxidos: Tenorite / Cuprite	yes					Flotation	multiple collectors		n.a.
Mexico	OP-07	Industrial	Oxide	a) Oxidos: (Fe, Cu) HxOx, Cuprite, Chrysocolla	yes	0.38%	0.19%			Flotation	conditioning for sulfides only. Plant was not designed for oxides. Feed Blending		25%
Peru	OP-08	Industrial	Oxides	a) Oxides: Malacite, Azurite	yes					Flotation	multiple, sequential collectors + NaSH, 15% solids in flotation feed. Feed Blending		marginal 2%
Chile	OP-09	Laboratory	Oxide, Mixed	a) Oxides: Atacamite, Chrysocolla, Malacite, Azurite, c) Sulfides: Chalcopyrite, Pyrite	yes		0.20%			Flotation	multiple, sequential collectors + NaSH, 20% solids in flotation feed		30.5% to 60.5%